

JE 30890-0001



# Model 30940-Series

## ELECTROMAGNETIC CLUTCH DRIVEN GENERAL PURPOSE WATER PUMP

### FEATURES

- Body: Bronze, One-piece
- Impeller: Jabsco Neoprene
- Shaft: Stainless Steel
- Clutch: 7" "B" Groove Pulley
- Ports: 2" Hose Barb
- Seal: Carbon-Ceramic Face Type
- Bearings: Sealed Ball Type
- Shipping Weight: 14 lb (6,3 kg)

### APPLICATIONS

**MARINE:** pumping bilges, washdowns, circulating water in bait tanks.

**INDUSTRIAL:** circulating and transferring, sump drainage,

**FARMING:** pumping water for stock, pumping water from shallow wells and cisterns, etc.

**PUBLIC UTILITIES AND MUNICIPALITIES:** Under the hood mounting on service trucks for dewatering and draining meter boxes, manholes, excavations, and truck installation under hood for emergency pumping.

### OPERATING INSTRUCTIONS

1. **INSTALLATION** – Pump may be mounted in any position. Intake and discharge ports are determined by the direction of shaft rotation (refer to Dimensional Drawing). Before installing, turn the pump shaft in the direction of the operating rotation.
2. **DRIVE** – Belt drive with single "B" size belt.  
NOTICE: Overtight belt may reduce clutch or pump bearing life.



**WARNING** Exposed pulleys and belts can cause injury. Install shield around pulleys and belts.

3. **SPEED** – 100 RPM to the maximum shown in the performance table. Consult the factory for operation at speeds above those shown. For longer pump life, operate at lowest possible speeds.
4. **SELF-PRIMING** – Primes at low or high speeds. For a vertical lift of 6 feet (1,8m) when pump is in a dry condition, a minimum of 1000 RPM is required. Pump will produce a suction lift of up to 22 feet (6,7m) when wetted. **BE SURE SUCTION LINES ARE AIRTIGHT OR PUMP WILL NOT SELF-PRIME.**

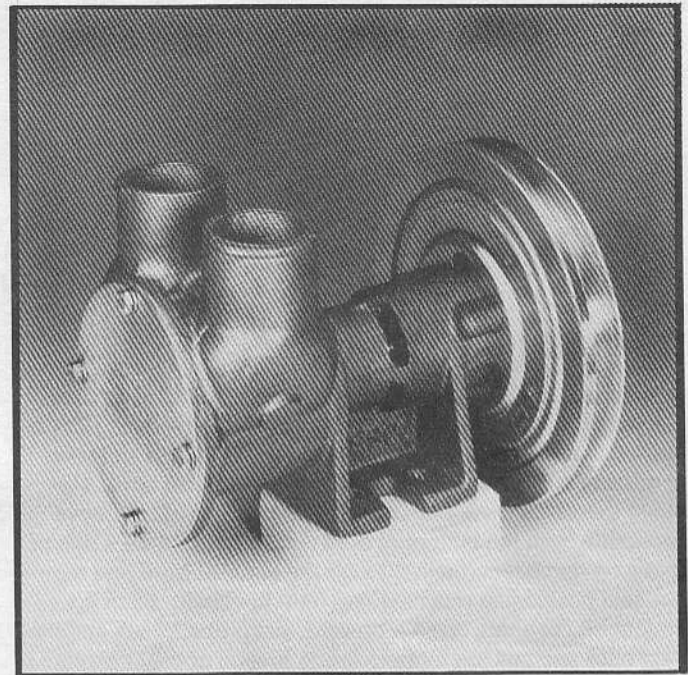

Model 30940-Series

### VARIATIONS AVAILABLE

- 30940-0001 12 Vdc Clutch
- 30940-0011 24 Vdc Clutch

5. **RUNNING DRY** – Unit depends on liquid pumped for lubrication. **DO NOT RUN DRY** for more than 30 seconds. Lack of liquid will damage the impeller.
6. **NOTICE** – Do not pump light fraction petroleum derivatives, solvents, thinners, highly concentrated or organic acids. Damage to pump may result. Consult Jabsco Chemical Resistance Table (available upon request from ITT Jabsco) for body material and impeller compound compatibility. If corrosive fluids are handled, pump life will be prolonged if pump is flushed with water after each use or after each work day.
7. **PRESSURES** – Consult Head Capacity Table for recommended maximum for continuous operation. If pressures exceed those shown, consult the factory.
8. **TEMPERATURES** –  
Neoprene Impeller: 45° to 180°F ( 7° to 82°C)
9. **FREEZING WEATHER** – Drain unit by loosening end cover. The following anti-freeze compounds can be used without any adverse effects to the impeller: Atlas "Perma-guard", Du Pont "Zerex" and "Telar", Dow Chemical "Dow-guard" and Olin Mathison "Pyro Permanent".  
**NOTICE** – To avoid pump damage, do not use petroleum based anti-freeze compounds or rust inhibitors.

## WIRING

Connect wires as shown for normal on-off operation. Install proper size fuse (see Electrical Specification Chart) in positive lead ahead of switch and as close to power source as possible.

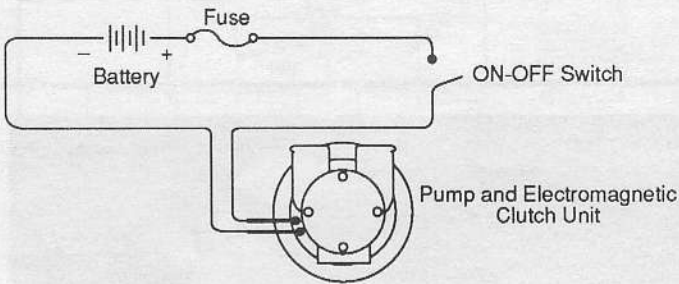

CLUTCH ELECTRICAL SPECIFICATIONS			
MODEL	VOLTAGE	AMP DRAW	FUSE SIZE
18330-0000	12	4	7
18330-0001	24	2	4

## SERVICE INSTRUCTIONS

### DISASSEMBLY

Remove the end cover screws, lock washers and end cover. Remove the end cover O-ring from the O-ring groove. With a large pair of water pump pliers, grasp the hub of the impeller and using a rotary motion pull it from the impeller bore. Remove the cam screw, cam screw O-ring and cam. Remove the wearplate from the bottom of the impeller bore. With a pair of retaining ring pliers reach through the impeller bore and remove the seal positioning retaining ring from the shaft. Slide the seal spacer off the shaft. With a hooked, stiff probe, reach into the seal bore and pull the rubber/carbon portion of the seal off the shaft. Then with the same probe it should be possible to reach between the wet end of the pump and the bearing housing and push the ceramic portion of the seal forward into the impeller bore so it can be pulled off the shaft. Ensure the rubber seal seat for the ceramic is also removed from the bottom of the seal bore. The seal may alternatively be removed by first pressing the shaft assembly from the pump body and then pushing the seal out of the seal bore from the bearing end of the pump.

To do this, remove the clutch assembly by loosening the two set screws that secure the clutch pulley to the shaft. Slide the pulley off the shaft and remove the woodruff key. Remove the three screws that secure the clutch coil to the body and remove the coil.

Then, to remove the shaft/bearing subassembly from the pump body, first ensure the seal retaining ring is removed from the shaft. Remove the bearing to body retaining ring from the drive end of the pump. From the impeller end of the pump, press the shaft/bearing subassembly from the pump body. The O-ring located next to the bearing nearest the impeller end of the shaft serves as a water slinger and may be removed if desired. Now with a 1" dowel or drift it is possible to reach through the bearing housing end of the pump and push all remaining seal components out of the seal bore.

Clean all parts and inspect for wear. If the cam has wear grooves on it which can be easily felt with your fingernail, it should probably be replaced. If the wearplate has wear grooves it should be reversed when installed or replaced. If the pump end cover has significant wear grooves it should be replaced. Wear to any of the aforementioned parts will reduce the pump's primeability. Rotate the bearings' outer races to ensure they rotate smoothly. If they grind, wobble or hang-up, the shaft/bearing subassembly should be replaced.

### ASSEMBLY

Position the slinger O-ring about 1/4" away from the bearing nearest the impeller end of the shaft. Press the shaft/bearing subassembly into the pump body. Install the bearing retaining ring in the retaining ring groove ensuring it is properly seated all around.

Slide the ceramic portion of the seal with rubber seal seat attached onto the shaft and press into the seal bore so the white ceramic faces the impeller bore. Slide the carbon portion of the seal onto the shaft until it contacts the ceramic. Position the seal spacer on the shaft against the seal and push it down to expose the retaining ring groove. Install the seal retaining ring ensuring it is fully seated in the retaining ring groove. Drop the wearplate into the impeller bore ensuring the notch in the wearplate aligns with the locator pin position (centered in cam area) in the body.

Position the cam in the impeller bore and secure it in place with the cam screw fitted with the O-ring seal. With a rotary motion (in the normal installed direction of rotation) push the impeller into the impeller bore. Align the flats of the impeller insert with the flats on the shaft then push the impeller with a rotary motion down until it bottoms in the impeller bore. Position the end cover O-ring in the O-ring groove and install the end cover with end cover screws and lock washers.

To install the clutch assembly, first secure the clutch coil with the three retaining screws and lock washers to the rear of the pump body. Align the coil radially so it is centered as much as possible on the pump shaft.

Position the woodruff key in the key-way ensuring it is fully seated in key way and flat of the key is parallel with the shaft. Slide the clutch pulley onto the shaft and woodruff key until it contacts the coil. Then pull it back away from the coil 1/16" - 3/32" (1,5 - 2,0mm) and secure in place on the shaft with the two set screws. Rotate pulley to ensure it spins freely and does not rub.

Recommended torque for the cam screw is 45-50 in/lbs and the end cover screws 65-70 in/lbs.

Recommended torque for the clutch coil retention screws is 65-70 in/lbs and clutch pulley set screws is 40-50 in/lbs.

## EXPLODED VIEW

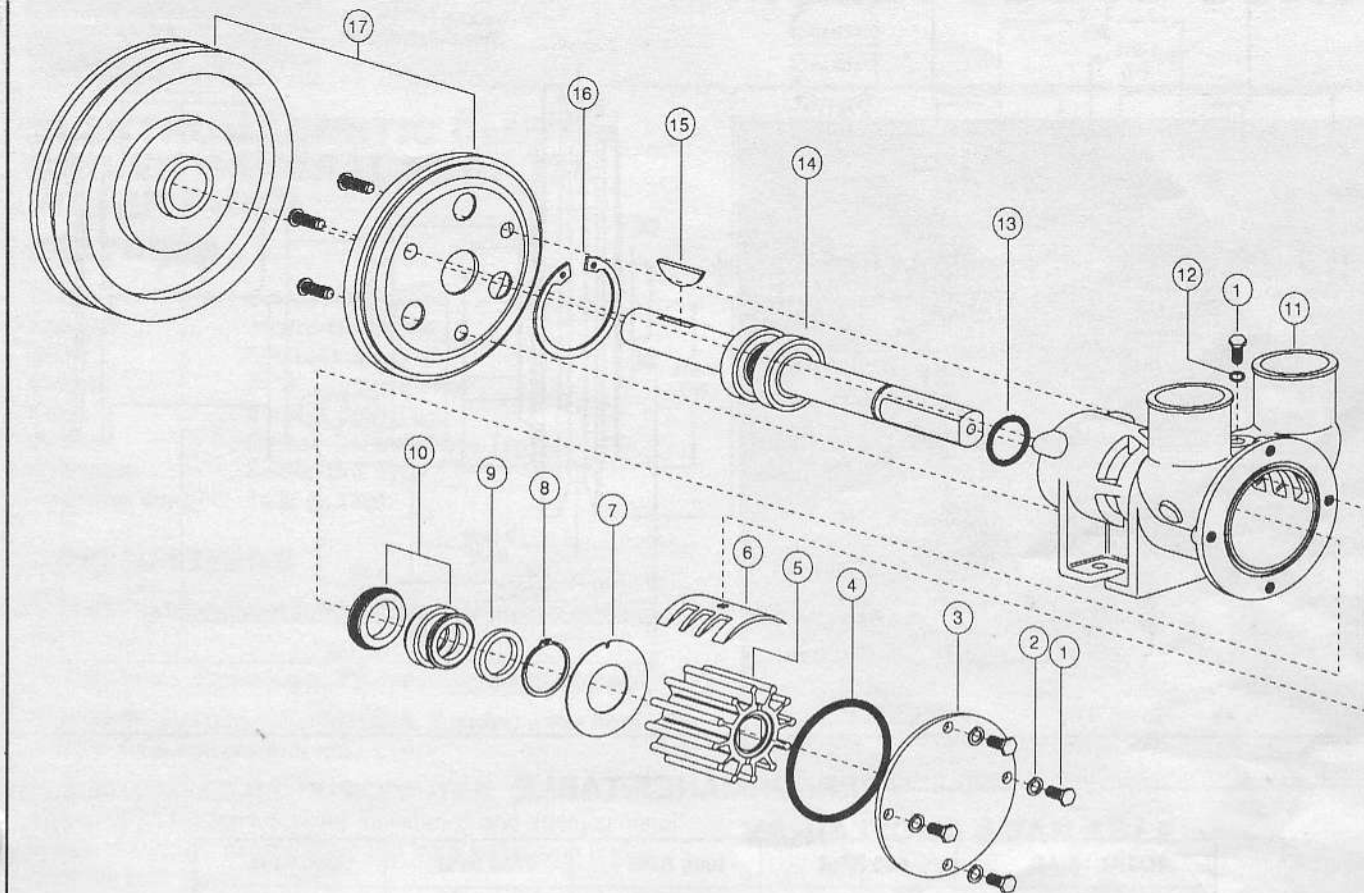

Key	Part Number	Description	Quantity
1	} 18753-0346 {	Screw, H.H. M6 - 1.0 x 16 mm S.S.	5 per kit
2		Lock Washer M6 S.S.	4 per kit
3	30914-1000	End Cover	1
4*	18753-0343	O-ring, End Cover	1
5*	30919-0001	Impeller	1
6	30929-1000	Cam/Dowel Pin Assy.	1
7	30915-1000	Wearplate	1
8	18753-0345	Retaining Ring	1
9	18753-0428	Spacer	1
10*	18753-0342	Seal Assy. (Carbon & Ceramic)	1
11	30911-1000	Body	1
12*	18753-0340	O-ring, Cam Screw	1
13	92000-0560	O-ring, Slinger	1
14	30912-1000	Shaft/Bearing Subassembly	1
15	18753-0341	Woodruff Key	1
16	18753-0344	Retaining Ring	1
17	30939-1000	Clutch Assy. 12 Volt with mounting screws	1
	30939-1001	Clutch Assy. 24 Volt with mounting screws	1
	90135-0001	Service Kit*	

\* Parts included in Service Kit

## DIMENSIONAL DRAWING

INCHES (millimetres)

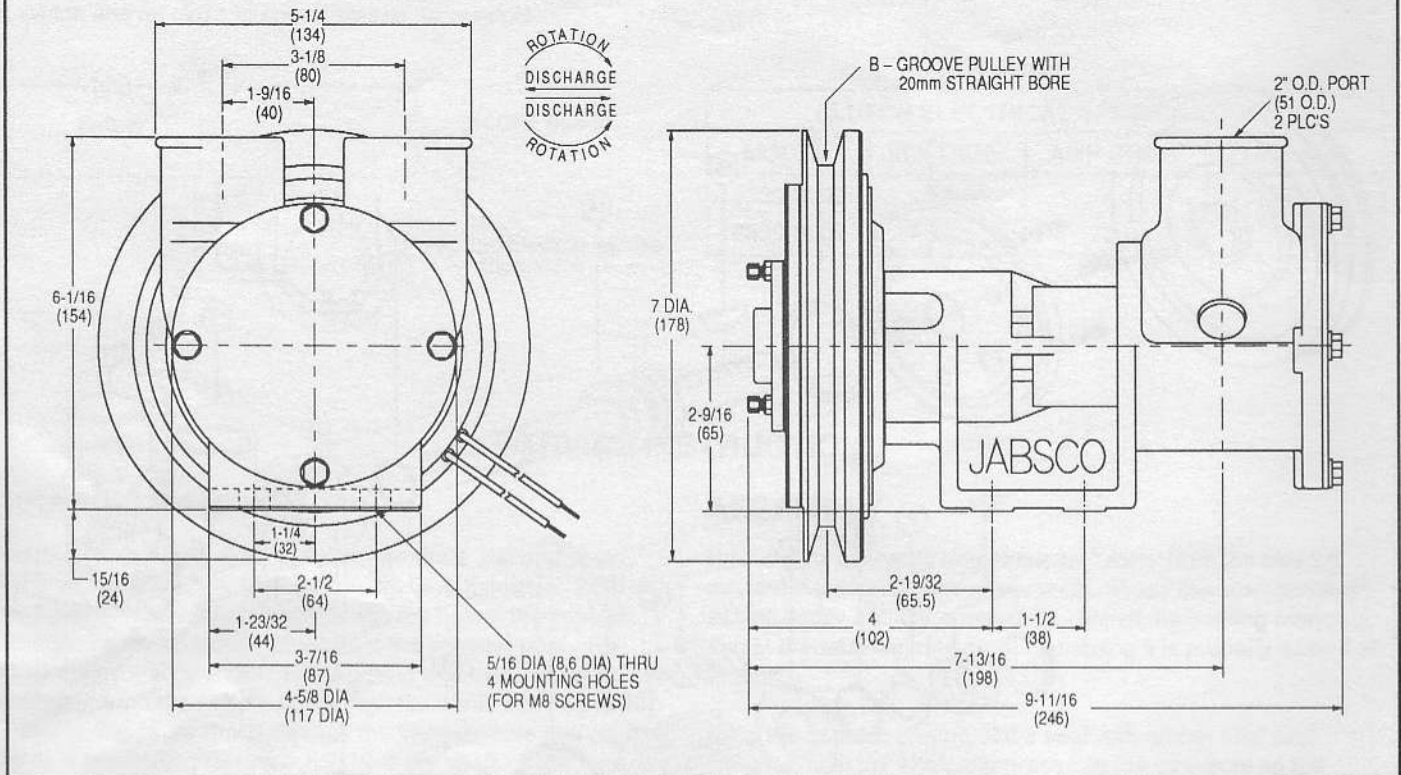

## PERFORMANCE TABLE

TOTAL HEAD		500 RPM		1000 RPM		1750 RPM		3000 RPM	
PSI (kg/sq cm)	Feet of Water (Metres)	GPM (L/Min)	HP	GPM (L/Min)	HP	GPM (L/Min)	HP	GPM (L/Min)	HP
4.3 (0,3)	10 (3,0)	12 (45)	1/4	26 (98)	1/3	45 (170)	3/4	76 (288)	2
8.7 (0,6)	20 (6,1)	11 (42)	1/4	24 (91)	1/2	44-1/2 (168)	3/4	73 (276)	2
17.3 (1,2)	40 (12,2)	9-1/2 (36)	1/4	22 (83)	1/2	40 (151)	1	66-1/2 (252)	2
26.0 (1,8)	60 (18,3)	8 (30)	1/3	19-1/2 (74)	1/2	37 (140)	1	61 (231)	2-1/2
34.6 (2,4)	80 (24,4)					33-1/2 (127)	1-1/2	55-1/2 (210)	3

**NOTE:** Table shows approximate head-flow for new pump in U.S. gallons per minute and litres per minute. Progressively longer life may be expected as operating pressures and speeds are reduced. Factory Application Engineering assistance is recommended for shaded area. High starting torque motors are required. Pump starting torque in dry condition (no fluid in pump body) is 86 inch-pounds and in wet condition (fluid in pump body) is 65 inch-pounds.

THE PRODUCTS DESCRIBED HEREIN ARE SUBJECT TO THE JABSCO ONE YEAR LIMITED WARRANTY, WHICH IS AVAILABLE FOR YOUR INSPECTION UPON REQUEST.

**ITT Jabsco**

ITT Fluid Technology Corporation  
1485 Dale Way, P.O. Box 2158, Costa Mesa, CA 92628-2158  
Tel: (714) 545-8251; Fax: (714) 957-0609  
Bingley Road, Hoddesdon, Hertfordshire EN11 0BU England  
Tel: 0992-467191; Tlx: 263251 G; Fax: 0992-467132