

**JABSCO**

# Model 30420-2 SERIES

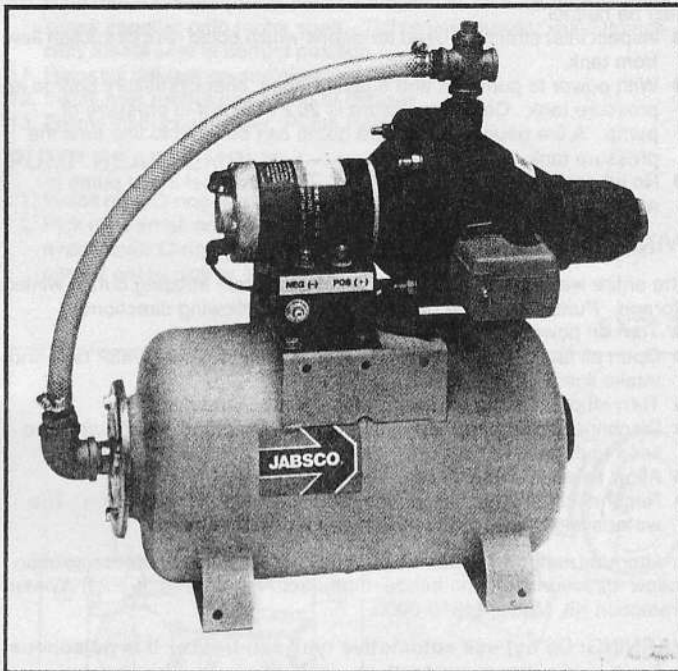

## APPLICATION/PERFORMANCE

### HIGH DEMAND WATER SYSTEM

Jabasco Model 30420 Water Pressure System provides "at home" convenience for the larger pleasure boat and commercial vessels. The jet type centrifugal pump provides up to 10 gallons of fresh water per minute, to service multiple fixtures both hot and cold. The prepressurized accumulator tank eliminates rapid cycling and ensures smooth flow and even temperature mix at showers.

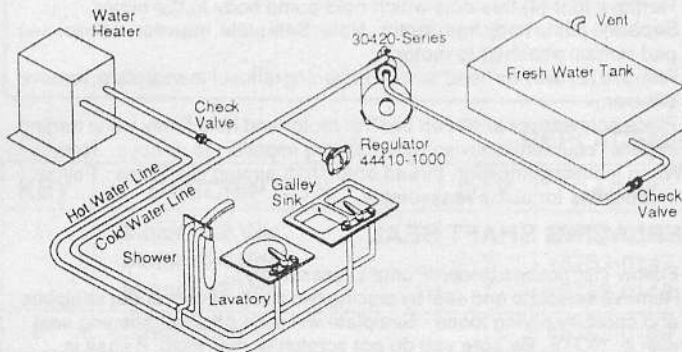

## HIGH DEMAND WATER PRESSURE SYSTEM

### FEATURES

- Quiet Operation
- High Capacity
- Compact Size
- Pre-pressure Air Tank
- Stainless Steel Hardware
- 1" Check Valve Included

### SPECIFICATIONS

Flow: Up to 10 GPM  
 Pump: Jet Type Centrifugal  
 Motor: 1/2 HP Permanent Magnet  
 Vertical Suction  
 Lift: 6' (1,8m)  
 Ports: 1" NPT Inlet, 3/4" NPT Outlet  
 Dimensions: 24-1/4" (616mm) x 22-1/2" (572mm) x 10" (254mm)  
 Weight: 45 lbs. (20,5 kg)



## INSTALLATION

Secure unit on solid, level surface with four (4) 5/16" bolts. Note: If space is limited, pump may be dismantled from tank and located separately. Install check valve in suction line as close to water supply tank as possible. To improve repriming from a dry tank condition, loop suction line above or level with the discharge port. IMPORTANT: Use Teflon\* tape for making all threaded connections to pump itself. Do not use pipe joint compounds on pump; they can react with plastic in pump compound.

Inlet plumbing must be 1" I.D. non-collapsible or reinforced hose. Main distribution line from pump outlet must be 3/4" I.D. with branch and individual supply lines to outlets no smaller than 3/8". Avoid any kinks or fittings which could cause excessive restriction. The Jabasco accumulator tank is precharged at 20 PSI. No further attention should be needed.



This unit is not ignition protected. Do not install in an area where flammable vapors may collect, such as the bilge of a gasoline powered vessel. Failure to follow warning may result in property damage, personal injury or death.

Model	Voltage	Amp. Draw Nom.	Circuit Breaker**	Open Flow	Pressure (Nom.) Cut-in	Cut-off
30420-2012	12 Vdc	36	50 Amp	9.5 GPM	18 PSI	32 PSI
30420-2024	24 Vdc	25	35 Amp	10 GPM	26 PSI	40 PSI
30420-2032	32 Vdc	20	25 Amp	10 GPM	26 PSI	40 PSI

\* Teflon is a trademark of E.I. DuPont de Nemours and Company.

\*\* Manual Reset

Model 30420-2 SERIES

## WIRING

PROPER POLARITY MUST BE MAINTAINED TO ENSURE CORRECT OPERATION OF PUMP. REVERSE POLARITY WILL DAMAGE PUMP. IMPELLER IS SCREWED ONTO SHAFT AND WILL LOOSEN IF OPERATED IN REVERSE ROTATION.

These units have a relatively high amperage draw and must be powered from an independent circuit of adequate capacity to keep voltage drop to a minimum during starting and running. Particular attention must be paid to proper size wiring to ensure optimum operation of unit. For longer runs, increase wire in accordance with wire selection chart. For proper electrical connections, refer to the polarity label (+ -) on unit, and diagram below. Install rubber terminal boot on wire leads before attaching and crimping ring terminals. Connect ground wire, if used, to green grounding terminal using ring terminal. Connect positive (+) lead from power source to positive terminal and negative (-) lead from battery ground to negative terminal.

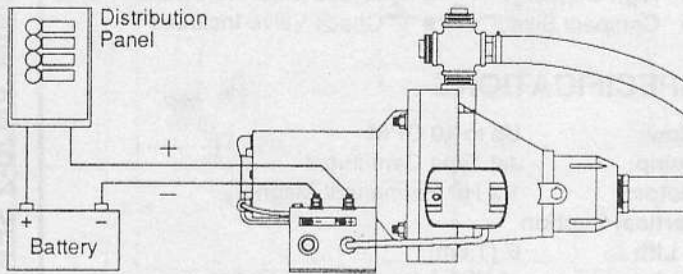

Wire size chart (AWG-COPPER) @ 3% V Drop  
Length of circuit in feet (sum of Positive & Negative wire lengths)

VOLT	0-20'	21-30'	31-40'	41-50'	51-60'
12	# 6	# 4	# 2	# 2	# 1
24	#10	# 8	# 6	# 6	# 6
32	#12	#10	#10	# 8	# 8

## OPERATION

**IMPORTANT: NEVER RUN PUMP DRY. TO RUN PUMP WITHOUT WATER MAY DAMAGE SEALS OR OTHER INTERNAL PARTS. TO PREVENT DAMAGE TO INTERNAL PARTS, FILL PUMP WITH WATER BEFORE STARTING.**

- Remove priming plug located on top of system and fill pump and suction pipe with water.
- Replace priming plug, using teflon tape on plug threads.
- Open one outlet, hot and cold.
- Turn on power to pump - Move lever on side of pressure switch to start position. Hold lever in this position until sufficient pressure is built up in the system and the pump will run when the lever is released. **DO NOT** run pump for more than 60 seconds. Unit should pump water; if not, repeat above steps. On first use of pump, it may be necessary to reprime pump two or three times.
- Close outlet when it starts to deliver a steady stream of water (close cold water first).
- Observe the pump. Check to be sure pump stops soon after the outlet is closed.
- Pump is now ready for automatic operation. It will start when system pressure drops to 18 PSI (12V) [26 PSI (24/32V)] and shut off when system pressure reaches 30 PSI (12V) [40 PSI (24/32V)]. Note: Your water system may be fine tuned by adjusting the pressure switch.  
**Range:** Always adjust the range spring nut (A) [see drawing on back page]. First, until the desired operating point on falling pressure is obtained. Keep in mind this adjustment changes both the high (off) and the low (on) operating point. Turning the unit (A) clockwise will increase the setting.  
**Differential:** Set the operating point on rising pressure by adjusting the differential spring nut (B). Turning the nut (B) clockwise increases the pressure difference between the high (off) and the low (on) operating points by increasing the high operating point only.

- Turn off power to pump when vessel is left unattended.
- Repriming should not be necessary unless pump is unused for months.

**CAUTION:** Motor case will get hot. Prolonged contact during operation may cause a burn.

## MAINTENANCE

It is recommended, as with other major systems aboard, that periodic inspections are made of the Jabsco Water System. The following checklist may be helpful:

- Inspect inlet strainer if used for debris which could restrict suction flow from tank.
- With power to pump off and a faucet open, check pressure charge in pressure tank. Correct pressure is 20 PSI or cut-in pressure of pump. A tire gauge and bicycle pump can be used to fine tune the pressure tank.
- No lubrication to unit is necessary. The shaft seal in the pump is water lubricated and self-adjusting.

## WINTER STORAGE

The entire water system should be protected from freezing during winter storage. Pump should be drained, using the following directions:

- Turn on power to pump.
- Open all faucets and drains and allow pump to empty water tank and intake line.
- Turn off pump and remove priming plug to vent pump.
- Disconnect discharge and intake lines from pump. Allow pump and lines to drain.
- Allow time for water heater to empty.
- Reconnect the lines, close the drains, but leave faucets open. The water system is now dry and ready for winter storage.

An alternate method is to use the potable water system anti-freeze solution. Follow directions of anti-freeze manufacture and use a PAR Winter Protection Kit, Model 44610-0000.

**WARNING: Do not use automotive type anti-freeze. It is poisonous and can cause illness or death.**

## SERVICE INSTRUCTIONS

**NOTICE: BEFORE SERVICING PUMP, TURN OFF POWER AND OPEN FAUCETS TO RELIEVE PRESSURE IN WATER DISTRIBUTION SYSTEM.**

### PUMP DISASSEMBLY/IMPELLER REPLACEMENT

1. Turn off power to pump.
2. Disconnect discharge and inlet line.
3. Disconnect hose from tank to cross fitting.
4. Remove pressure switch tube from compression elbow on pump body and allow pump to drain.
5. Remove four (4) hex nuts which hold pump body to the motor.
6. Separate pump body from motor. Note: Seal plate, impeller, diffuser and pad remain attached to motor.
7. Remove (2) two hex head screws fastening diffuser to seal plate; remove diffuser.
8. Place screwdriver in slot on back of motor and hold firmly while turning impeller counterclockwise (when facing impeller) to remove. Note: When installing impeller, thread onto shaft turning clockwise. Follow instructions for pump reassembly.

### REPLACING SHAFT SEAL

1. Follow instructions under "Pump Disassembly".
2. Remove sealplate and seal by placing two screwdrivers under sealplate and carefully prying loose. Sealplate will slide off shaft bringing seal with it. **NOTE:** Be sure you do not scratch or mar shaft; if shaft is marred, it must be dressed smooth with fine emery or cloth before installing new seal.
3. Place seal plate face down on flat surface and tap out stationary half of seal. **NOTE:** Be sure you tap on ceramic seat, not on insert.
4. Clean seal cavity in heat sink. Do not disturb heat sink.
5. Wet outer edge of O-ring on ceramic seat with liquid soap.
6. With thumb pressure, press ceramic seal half firmly and squarely into seal cavity in heat sink. Polished face of ceramic seat is up. If seal will not seal correctly, remove, placing seal face up on bench. Reclean cavity. Seal should now seat correctly.

7. Reinstall seal plate on motor flange, making sure that it is right side up.
8. Apply liquid soap sparingly to inside diameter of rotating seal member.
9. Slide rotating seal member (carbon face first) onto shaft until rubber drive ring hits shaft shoulder. Note: Be sure not to nick or scratch carbon face of seal when passing it over threaded shaft end or shaft shoulder. The carbon surface must remain clean or short seal life will result.
10. Hold motor securely with slotted screwdriver on back of motor and screw impeller onto motor shaft. Tightening impeller will automatically locate seal in correct position.
11. Reinstall diffuser on sealplate with two screws.
12. Install new rubber pad to top of diffuser.
13. Follow instruction under "Pump Reassembly".

### MOTOR REPLACEMENT

1. Turn off power to pump.
2. Follow instructions under "Pump Disassembly" to disconnect pump from motor (steps 1- 8).
3. Disconnect power leads from back of motor. Note: Mark wires for correct reassembly.
4. Remove two No. 1/4-20 screws located under motor mounting bracket
5. Replace motor.
6. To reinstall motor, reverse steps 3 - 5.
7. Follow instructions under "Pump Reassembly" (steps 3- 8).

### PUMP REASSEMBLY

1. Install new O-ring gasket on sealplate.
2. Pick up a small amount of liquid soap on one finger and spread evenly over O-ring gasket for lubrication during reassembly. Be careful not to nick or tear O-ring.

### EXPLODED VIEW

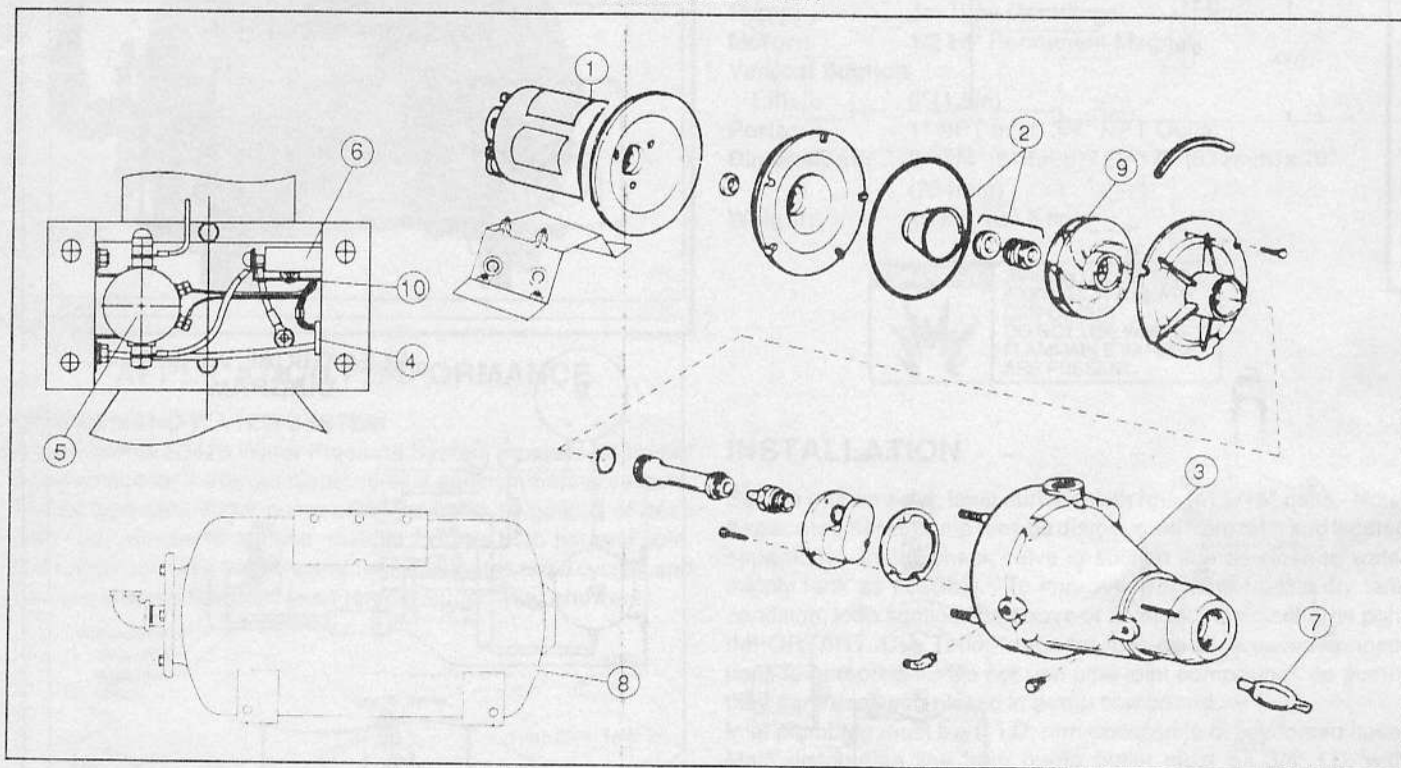

### REPLACEMENT PARTS LIST

KEY	DESCRIPTION	QTY.	PART#
1	Motor 12 Vdc	1	18753-0146
	Motor 24 Vdc	1	18753-0147
	Motor 32 Vdc	1	18753-0148
2	Seal/O-ring Kit	1	18753-0149
3	Pump Assembly	1	18753-0150
4	Pressure Switch	1	18753-0348
5	Solenoid 12V	1	18753-0151
	Solenoid 24V	1	18753-0152
	Solenoid 32V	1	18753-0153

KEY	DESCRIPTION	QTY.	PART#
6	Circuit Breaker 12V	1	18753-0154
	Circuit Breaker 24V	1	18753-0155
	Circuit Breaker 32V	1	18753-0156
7	Check Valve 1"	1	18753-0157
8	Accumulator Tank	1	18753-0158
9	Impeller Kit	1	18753-0338
10	Snubber Assembly	1	18753-0349
	Pump/Motor 12 Vdc	1	30430-0012
	Pump/Motor 24 Vdc	1	30430-0024
	Pump/Motor 32 Vdc	1	30430-0032

NOTE: Maximum Shut Off Settings  
 12 Volt Models - 27 PSI  
 24 Volt Models - 35 PSI  
 32 Volt Models - 35 PSI

**DIMENSIONAL DRAWING**

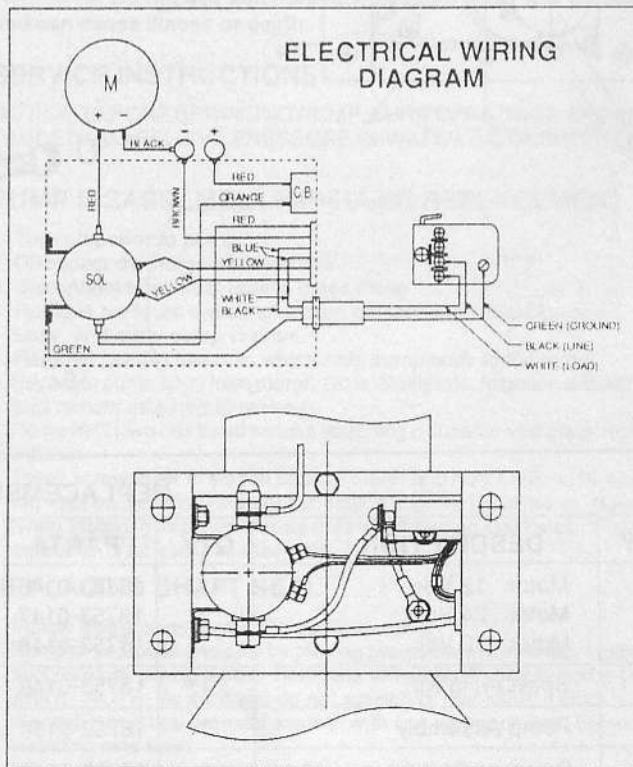
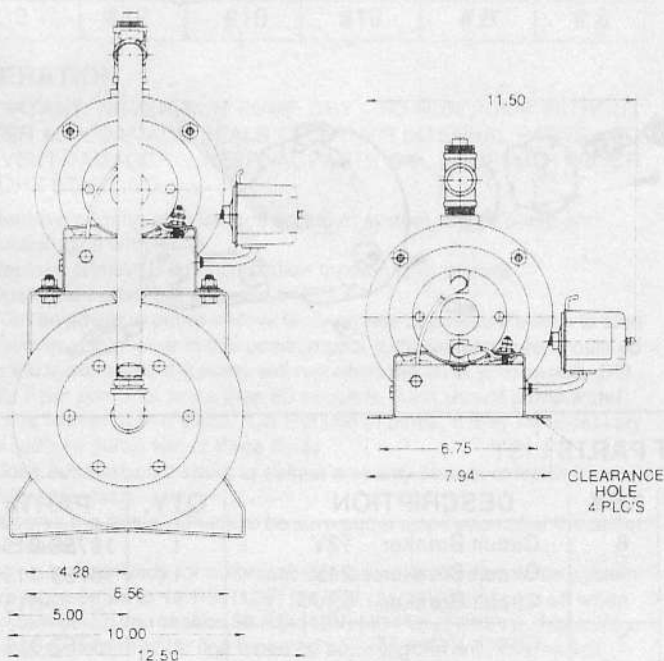
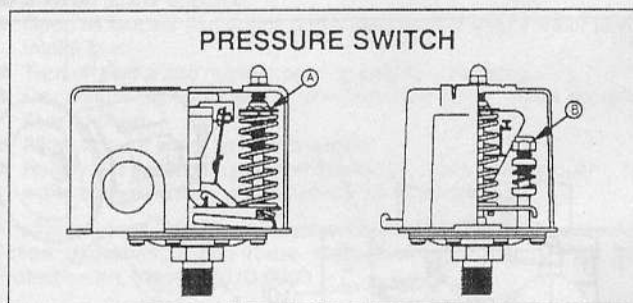
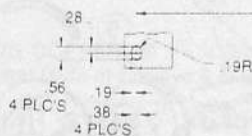
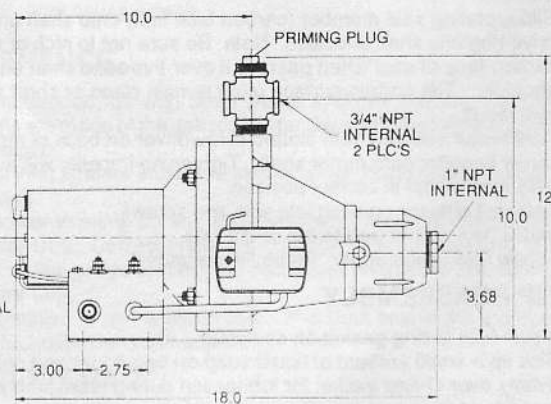
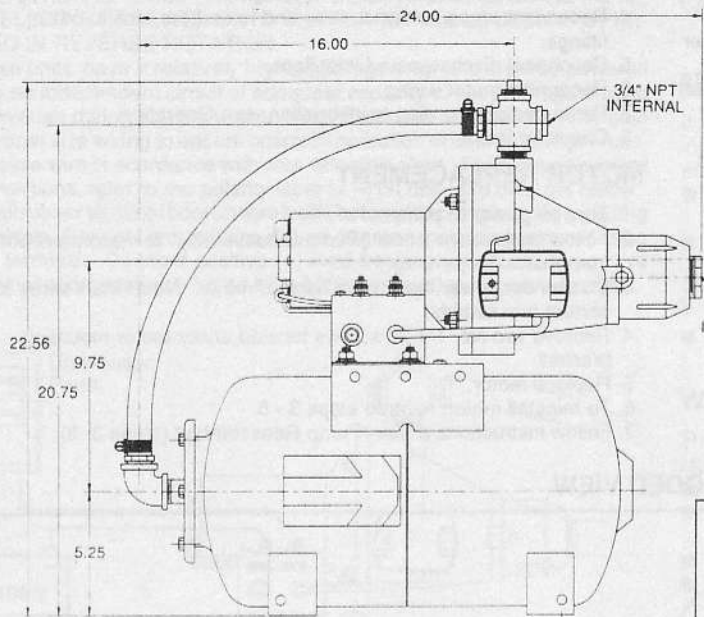

THE PRODUCTS DESCRIBED HEREIN ARE SUBJECT TO THE JABSCO ONE YEAR LIMITED WARRANTY, WHICH IS AVAILABLE FOR YOUR INSPECTION UPON REQUEST.

**ITT Jabsco**

ITT Fluid Technology Corporation  
1485 Dale Way, P.O. Box 2158, Costa Mesa, CA 92628-2158  
Tel: (714) 545-8251; Fax: (714) 957-0609  
Bingley Road, Hoddesdon, Hertfordshire EN11 0BU England  
Tel: 0992-467191; Tlx: 263251 G; Fax: 0992-467132