

Model 30140-0003

SELF-PRIMING PUMP

Built In Dry Running Capability (up to 15 minutes) After Initial Priming

FEATURES

- Body:** Bronze Construction
- Impeller:** JABSCO Nitrile
- Shaft:** 316 Stainless Steel Impeller Sleeve over Motor Shaft
- Wearplate:** Replaceable
- Shaft Seal:** Lip Type
- Ports:** 1" NPT, Internal
- Motor:** 1/3 HP, Capacitor Type, Open Drip Proof, Overload Protector, 1725 RPM, 60 Hz, Single Phase, 115 Vac, with 8 foot cord and plug wired for 115 Vac operation
MOTOR IS NOT EXPLOSION PROOF!
- Weight:** 23 lb (10.4 kg)

TYPICAL APPLICATIONS

- MARINE:** Bait Tank Circulation; Washdown, Utility Dockside Pump.
- INDUSTRIAL:** Industrial Filling Systems; Utility Shop Pump; Transfer Gum Arabic, Transfer Distilled Water; Recharge Water Softeners; Hydro-static Pressure Testing; Sump Pumping.
- FOOD, BEVERAGE & DAIRY:** Circulate Cooling Water; Defrost Refrigeration Coils; Fill Drums; Wash Down Equipment and Floors; Utility Pump.
- HOME:** Fill and Empty Tubs, Pools; Empty Basements and Cesspools; Water Systems; Water Lawns and Gardens; Remove Water from Low Areas; Recharge Water Softeners.
- PLUMBING:** Empty Clogged Drains, Empty Sumps, Sinks and Tubs; Pump Out Water Closets.
- FARM:** Fill Tractor Tires, Water Tanks; Pump out Silo Pits (liquid manure); Flush and Clean Animal Pens.
- CONTRACTORS:** Remove Water from Excavations; Supply Water to Mortar Boxes; Cement Mixing; Washdown Equipment.



Model 30140-0003

HEAD CAPACITY TABLE

TOTAL HEAD				CAPACITY	
PSI	(bar)	FEET	METERS	GPM	LPM
5	(.35)	11.6	3.5	9	34
10	(.69)	23.1	7.0	7	26
15	(1.0)	34.7	10.6	5	19
20	(1.4)	46.2	14.1	3	11

Progressively longer life may be expected as operating pressures are reduced.

Table shows approximate Head-Flow for new pump in U.S. gallons and litres with nitrile impeller.

	Explosion hazard. Do not use where flammable vapors are present. Do not pump solvents, thinners or gasoline. To do so can cause an explosion which can result in injury or death.
--	--

DIMENSIONAL DRAWING

INCHES (MILLIMETRES)

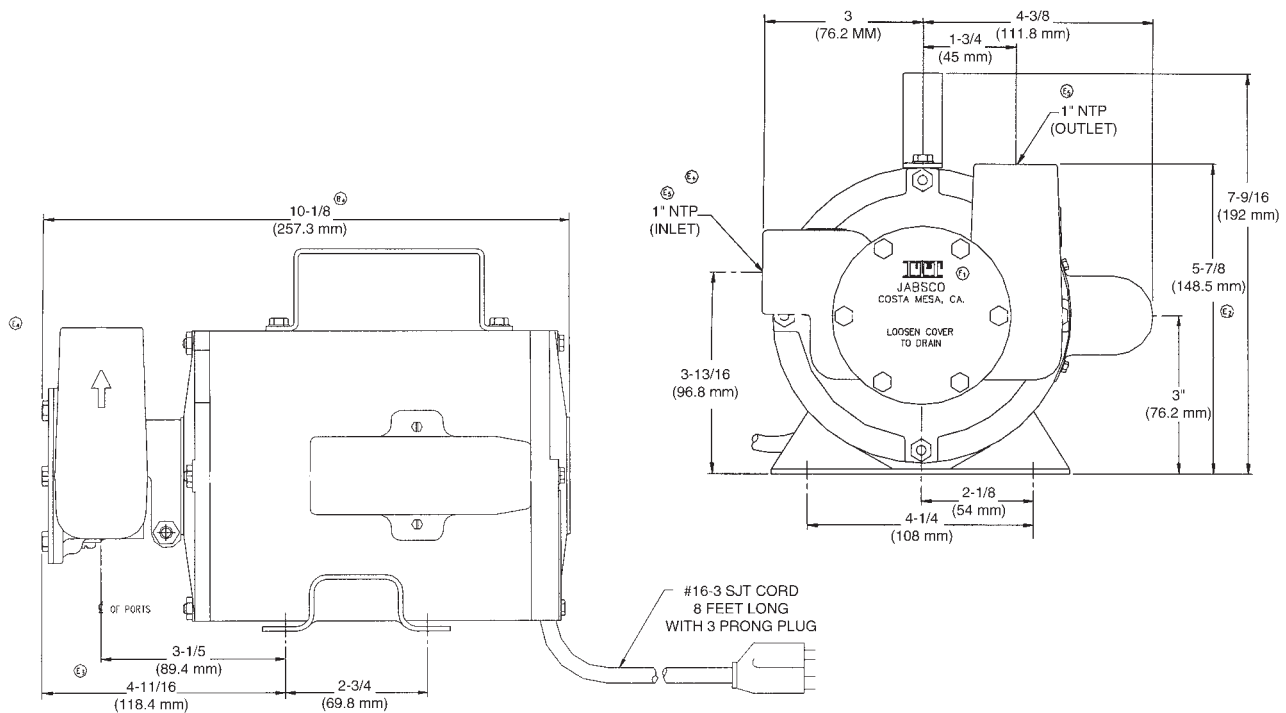

OPERATING INSTRUCTIONS

INSTALLATION

1. Pump must be mounted in a horizontal position. Mounting in horizontal position will maximize the "Dry Running" time.
2. Drive – Direct.
3. SELF-PRIMING – Pump will produce a suction lift approaching 10 feet when dry and a lift up to 22 feet when primed. BE SURE SUCTION LINES ARE AIR-TIGHT or pump will not self-prime. Initial start up without any retained fluid should be for the short time possible-less than 1 minute recommended.
4. RUNNING DRY – This pump has a post operational "Dry Running" capability. This means once the inlet supply has dried up, the pump will run with minimal potential for impeller damage due to "dry running" by virtue of retaining trapped liquid in the pump for approximately 10 minutes. For optimum impeller life pump should be manually turned off as soon as inlet line is empty.
5. NOTICE – Do not pump solvents, thinners, highly concentrated organic acids. Impeller and pump damage may occur. If corrosive fluids must be handled, consult Jabsco Chemical Resistance Chart (which is available upon request from ITT Jabsco). Pump life will be prolonged if pump is flushed with water after each use or after each work day.
6. PRESSURES – For continuous operation, discharge pressure should not exceed 20 psi (1,4 bar).
7. TEMPERATURES – Nitrile impeller supplied in pump is recommended for liquid temperatures of 50° to 180° F (10° to 83° C).
8. FREEZING WEATHER – Drain unit by loosening the end cover.

EXPLODED VIEW

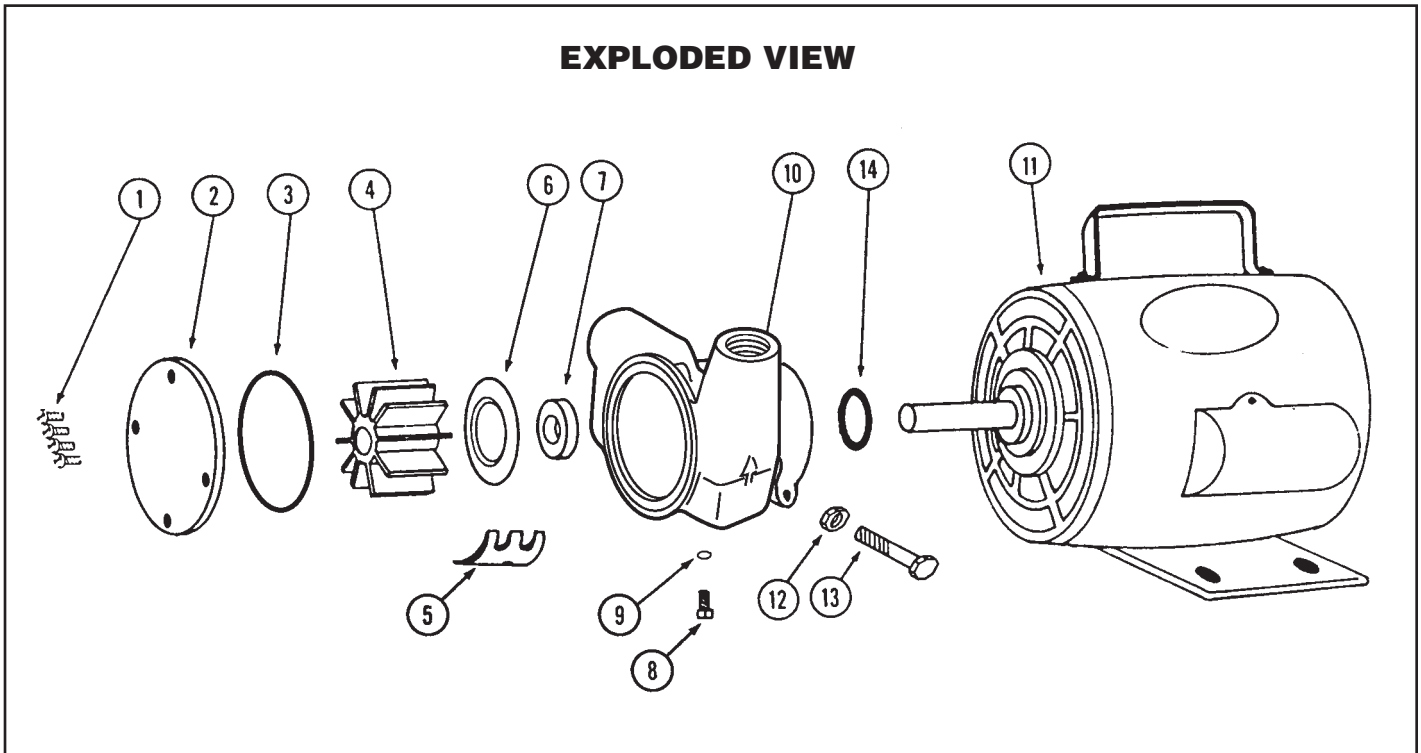

PARTS LIST

Key	Part Number	Description	Qty. Req.
1	91040-0035	Screws (End Cover)	6
2	11831-0000	End Cover	1
3	92000-1417	O-Ring	1
4	5929-0003	Impeller Nitrile	1
5	490-0000	Cam	1
6	2235-0000	Wearplate	1
7	92700-1040	Seal (shaft)	1

Key	Part Number	Description	Qty. Req.
8	91045-0434	Screw (Cam)	1
9	30141-0000	Body	1
10	18739-0000	Motor (ODP)	1
11	91085-0050	Nut (pump to motor bolt)	1
12	91095-0010	Bolt (pump to motor)	1
13	92000-0230	O-Ring	1

SERVICE INSTRUCTIONS

DISASSEMBLY

1. Remove end cover and O-ring.
2. Remove impeller. Use of Jabsco impeller tool 50070-0040 recommended.
3. Loosen cam screw and remove cam.
4. Remove wearplate with screwdriver or hooked wire.
5. Loosen nut at body clamp and remove body from motor.
6. Press out seal from motor mounting end of body towards impeller bore.
7. Slide O-ring off shaft.

NOTE: Inspect all parts for wear or damage and replace, if necessary. When returning pump to factory for repair, do not send motor unless it requires replacement. It is suggested that you contact local motor manufacturer's distributor for service.

ASSEMBLY

1. Press seal into seal bore with lip facing toward the impeller bore.
2. Install wearplate, aligning slot with dowel pin in body.
3. Lubricate impeller bore with water pump grease and install impeller in body. Use care not damage seal lip with impeller sleeve.
4. Install gasket and end cover, securing with end cover screws.
5. Install O-ring on motor shaft and position 1/4" from motor boss.
6. Apply a liberal coating of grease to the OD of the motor shaft.
7. Align ding in impeller with shaft keyway and install on motor.
8. Secure nut at clamp. Do not overtighten.

One Year Limited Warranty

A. LIMITED WARRANTY: ITT warrants that at the time of shipment, the products manufactured by ITT and sold hereunder shall be in conformity with applicable written specifications and descriptions referred to or set forth herein, free from defects in material and workmanship, merchantable, and suitable for a particular purpose, provided such is implied by State law under the circumstances of this sale.

B. WARRANTY ADJUSTMENT:

1. ITT agrees to repair or furnish a replacement for, but not to remove or install, any product or component thereof which, within one (1) year from date of purchase, shall upon test and examination by ITT prove defective within the above warranty. Receipt verifying purchase date is required to obtain adjustment.

2. Buyer shall notify ITT of any defect within this warranty no later than ninety (90) days after the defect is discovered.

3. No product will be accepted for return or replacement without the prior written authorization of ITT. Upon such authorization, and in accordance with instructions from ITT, the product will be returned to ITT, shipping charges prepaid by Buyer. Products returned to ITT will be addressed as follows:

**ITT JABSCO
1485 Dale Way**

Costa Mesa, California 92626-3998

Or to such alternate locations as may be designated on the product, its container, or this sheet. Repair or replacement made under this warranty will be shipped prepaid to Buyer.

C. EXCLUSIONS FROM WARRANTY AND LIMITATION OF LIABILITY:

1. The foregoing warranty is limited solely as set forth herein and applies only for the period designated above.

2. ITT SHALL NOT BE LIABLE FOR ANY LOSS, DAMAGE, SPECIAL OR CONSEQUENTIAL DAMAGE OF ANY KIND, WHETHER BASED UPON WARRANTY, CONTRACT, NEGLIGENCE, OR STRICT LIABILITY ARISING IN CONNECTION WITH THE SALE, USE, OR REPAIR OF THE PRODUCT.

3. THE MAXIMUM LIABILITY OF ITT IN CONNECTION WITH THIS WARRANTY SHALL NOT IN ANY CASE EXCEED THE CONTRACT PRICE FOR THE PRODUCT CLAIMED TO BE DEFECTIVE OR UNSUITABLE.

4. This warranty does not extend to any product manufactured by ITT which has been subjected to misuse, neglect, accident, improper installation, or use in violation of instructions furnished by ITT.

5. This warranty does not extend to or apply to any unit which has been repaired or altered at any place other than ITT's factory, or by persons not expressly approved by ITT, nor to any unit the serial number, model number, or identification of which has been removed, defaced or changed.

6. Components manufactured by any supplier other than ITT shall bear only that warranty made by the manufacturer of that product.

7. This warranty applies to products defined as "consumer products" by the Consumer Product Warranties Act as from time to time amended.

D. CONSUMER RIGHTS: This warranty gives you specific legal rights, and you may have other rights which vary from state to state. Some states do not allow exclusion or limitation of damages.

STANDARD WARRANTY: If the products manufactured and sold hereunder are not Consumer Products, the warranty extended to Buyer shall be as set forth in subparagraphs (A), (B), and (C), **EXCEPT THAT ALL EXPRESS OR IMPLIED WARRANTIES OR MERCHANTABILITY OR SUITABILITY FOR ANY PARTICULAR PURPOSE ARE EXCLUDED.**

Jabsco



ITT Industries
Engineered for life



U.S.A.
Jabsco
1485 Dale Way, P.O. Box 2158
Costa Mesa, CA 92628-2158
Tel: (714) 545-8251
Fax: (714) 957-0609

UNITED KINGDOM
Jabsco
Bingley Road, Hoddesdon
Hertfordshire EN11 OBU
Tel: +44 (0) 1992 450145
Fax: +44 (0) 1992 467132

CANADA
Fluid Products Canada
55 Royal Road
Guelph, Ontario N1H 1T1
Tel: (519) 821 -1900
Fax: (519) 821-2569

JAPAN
NHK Jabsco Company Ltd.
3-21-10, Shin-Yokohama
Kohoku-Ku, Yokohama, 222
Tel: 045-4758906
Fax: 045-475-8908

GERMANY
Jabsco GmbH
Oststrasse 28
22844 Norderstedt
Tel: +49-40-53 53 73 -0
Fax: +49-40-53 53 73 -11