



# Model 3010-Series

## SELF-PRIMING PUMPS

### FEATURES

- Body:** Phenolic Type Plastic
- Impellers:** Made of Neoprene, Nitrile or Viton\*
- Shafts:** Stainless Steel or Hastelloy
- Seal:** Lip Type
- Bearing:** Filled Teflon\* - Replaceable
- Ports:** 5/8 ID Hose - slip on ports
- Weight:** 8 oz (227 grams) approx.

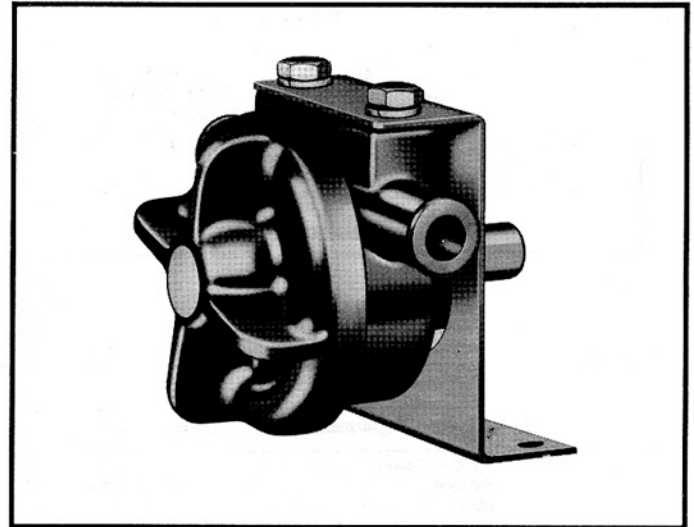

Model 3010-Series

### VARIATIONS AVAILABLE

MODEL	DESCRIPTION	MODEL	DESCRIPTION
3010-1011	Stainless Steel Shaft, Neoprene Impeller	3010-1021	Hastelloy "B" Shaft, Neoprene Impeller
3010-1013	Stainless Steel Shaft, Nitrile Impeller	3010-1023	Hastelloy "B" Shaft, Nitrile Impeller
3010-1014	Stainless Steel Shaft, Viton Impeller, Seal & O-ring	3010-1024	Hastelloy "B" Shaft, Viton Impeller, Seal & O-ring

### APPLICATIONS

**INDUSTRIAL:** Designed for: Carboy and drum transfer, hazardous chemical transfer and recirculation, recirculation of descaling compounds through refrigeration and condenser coils, printed circuit etching, general laboratory transfer, photographic fixes and developers, barium transfer, transfer ammonia on blueprint machines, silver recovery, demineralized and distilled water. See Jabsco Chemical Resistance Table (available upon request from ITT Jabsco), which has been prepared to help you select the most suitable impeller and pump material.

**316 SS** - Type 18-8 stainless steel. Possesses excellent corrosion resistance to a wide range of chemical solutions including ammonia, barium, many cyanide solutions, silver nitrate, photographic solutions including fix and developer.

**Hastelloy B** - (nickel-molybdenum-iron alloy). Possesses excellent resistance to certain highly corrosive fluids such as hydrochloric and muriatic acids, fluoboric acid, oxalic acid.

### SHAFT MATERIAL OPTIONS

The only metallic parts in the 3010 series are the shaft and drive pin. These two parts may be varied to cover a wide range of specialized chemical applications. For complete recommendations, consult Chemical Resistance Table (which is available upon request from ITT Jabsco).

Viton\* and Teflon\* are registered trademarks of DuPont Dow Elastomers L.L.C.

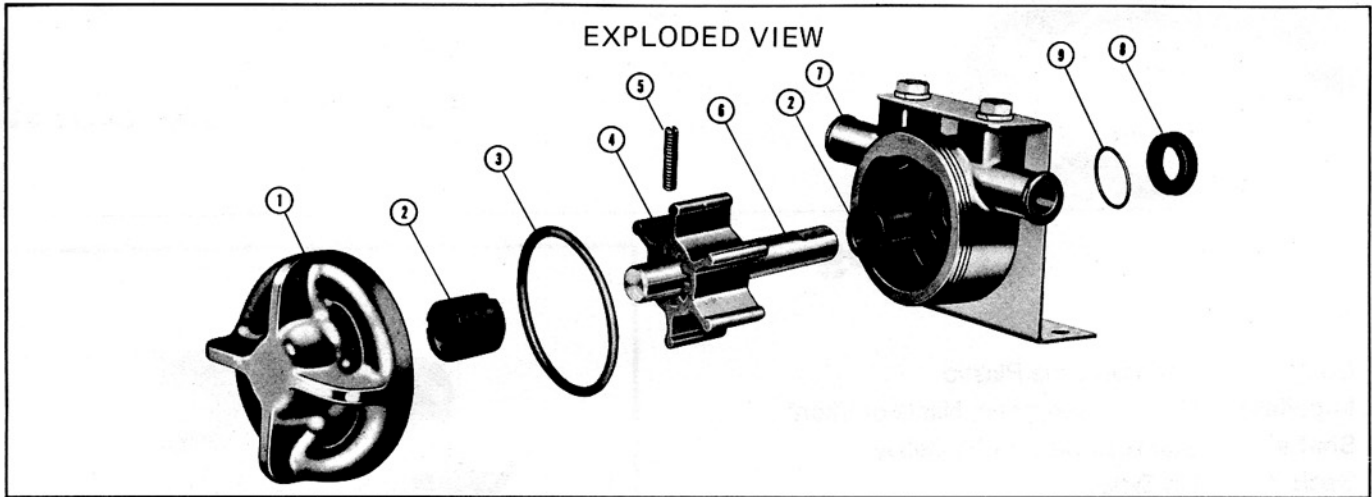

### PARTS LIST

Key	Description	Qty. Req.	Part No.
1	End Cover with Teflon Bearing	1	8187-0000
2	Teflon Bearing (Replaceable)	2	18700-0000
3	*O-ring (End Cover)	1	92000-0590 Standard Viton 92000-0790
4	*Impeller	1	3398-0001 Neoprene 3398-0003 Nitrile 3398-0004 Viton
5	*Pin (Impeller)	1	91029-0070 Stainless Steel 92850-0030 Hastelloy 'B'
6	Shaft	1	1983-0010 Stainless Steel 1983-0020 Hastelloy 'B'
7	Body with Bearing and Bracket	1	3015-1150
8	*Seal	1	93000-0030 Viton
9	*O-ring (Seal)	1	92000-0120 Standard Viton 92000-0800

\* Parts supplied in service kit

### SERVICE KITS

PUMP MODEL NUMBER	SERVICE KIT NUMBER
3010-1011	90026-1011
3010-1013	90026-1013
3010-1014	90026-1014
3010-1024	90026-1024

### HEAD CAPACITY TABLE

TOTAL HEAD P.S.I. (kg/sq cm)	FT. of WATER (meters)	500RPM		1160RPM		1750RPM	
		G.P.M. (l/min)	HP	G.P.M. (l/min)	HP	G.P.M. (l/min)	HP
4.3 (0,3)	10 (3,0)	1.3 (4,9)	1/6	3.5 (13,2)	1/6	5.8 (22,0)	1/4
8.7 (0,6)	20 (6,1)	.5 (1,9)	1/6	2.5 (9,5)	1/5	5.0 (18,9)	1/4
13.0 (0,9)	30 (9,1)	-	-	1.4 (5,3)	1/4	3.8 (14,4)	1/4

Progressively longer life may be expected as operating speeds are reduced. Capacitor start type motors are required.

Table shows approximate Head-Flow for new pump in U.S. gallons per minute with neoprene impeller. Capacities reduced approximately 10% for Nitrile and Viton impellers.

### SERVICE INSTRUCTIONS

#### Assembly

- Deform seal and install in body with lips facing impeller bore. Make sure seal is seated in its body groove. Remove bearing. Install O-ring onto cup of seal and lubricate inner seal lip with water pump grease. replace bearing in body.
- Slide impeller on shaft, aligning holes in impeller and shaft.
- Press in impeller drive screw.
- Lightly oil drive end of shaft and install in body with rotating motion.  
Be sure shaft is free of burrs. Be sure seal lip is not deformed by shaft.
- Install O-ring in cover.
- Screw cover onto body. TIGHTEN HAND TIGHT ONLY.

#### Disassembly

- Unscrew end cover. USE CARE NOT TO BREAK RIBS.
- Withdraw impeller and shaft assembly.
- Remove impeller to shaft screw, then slide impeller off the shaft
- Using a hooked wire, remove bearing from body. Remove O-ring from seal. Deform seal and remove from body. Use care not to mar or scratch seal bore.

**NOTE: Inspect all parts for wear or damage and replace if necessary.**

## ITT Jabsco

A Unit of ITT Fluid Technology Corporation

THE PRODUCTS DESCRIBED HEREIN ARE SUBJECT TO THE JABSCO ONE YEAR LIMITED WARRANTY, WHICH IS AVAILABLE FOR YOUR INSPECTION UPON REQUEST.



UNITED STATES  
1485 Dale Way, P.O. Box 2158  
Costa Mesa, CA 92628-2158  
Tel: (714) 545-8251  
Fax: (714) 957-0609

UNITED KINGDOM  
Bingley Road, HoddesdonHertfordshire  
EN11 0BU  
Tel: +44 (0) 1992 450145  
Fax: +44 (0) 1992 467132