

**JABSCO® PUMPS**  
**SELF-PRIMING PUMPS**

**MODEL: 2760-0001**

Formerly 2760 1/4  
**PRODUCT DATA**

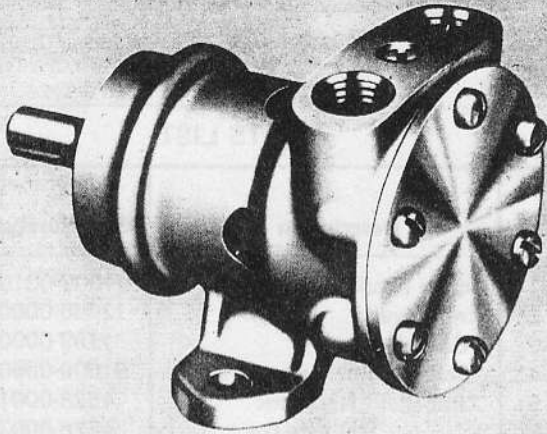

MODEL: 2760-0001

**DESIGN FEATURES**

- Body: **Bronze**
- Impeller: **Jabco Neoprene Compound**
- Shaft: **Bronze**
- Wear Plate: **Replaceable**
- Shaft Seal: **Lip Type**
- Bearings: **Sealed Ball Bearing**
- Ports: **1/4" NPT**
- Weight: **1 1/2 lbs. (approx.) (0,7 kg)**

VARIATION AVAILABLE: 2760-0003 Nitrile Impeller

**APPLICATIONS**

**MARINE:** Engine cooling, Pumping bilges, Washdowns, Circulating water in bait tanks.  
**INDUSTRIAL:** Circulating and transferring, Velocity-mixing, Pumping machine tool coolants, Return spill, Sump drainage, Chemicals, Pharmaceuticals, Soap, Liquors, Ink, Dyes, Alcohol, Various acids, Tanning liquors, Glycerine, Brine, etc.

**OPERATING INSTRUCTIONS**

1. **INSTALLATION**—Pump may be mounted in any position. Intake and discharge ports are determined by the direction of shaft rotation (refer to Dimensional Drawing). Before installing, turn the pump shaft in the direction of the operating rotation.
2. **DRIVE**—Belt or Direct with flexible coupling. Support shaft if pulley or coupling must be pressed on shaft. **BELT DRIVE**—Overtight belt load will reduce pump bearing life, and may bend shaft. **DIRECT DRIVE**—Clearance should be left between drive shaft and pump shaft when installing coupling. Always mount and align pump and drive shaft before tightening the coupling set screw.
3. **SPEEDS**—100 RPM to the maximum shown in the performance table. Consult the factory for operation at speeds above those shown. For longer pump life, operate at lowest possible speeds.
4. **SELF-PRIMING**—Primes at low or high speeds. For vertical dry suction lift of 10 feet, a minimum of 800 RPM is required. Pump will produce suction lift up to 22 feet when wetted. **BE SURE SUCTION LINES ARE AIR TIGHT OR PUMP WILL NOT SELF-PRIME.**
5. **RUNNING DRY**—Unit depends on liquid pumped for lubrication. **DO NOT RUN DRY** for more than 30 seconds. Lack of liquid will burn the impeller.
6. **CAUTION**—Do not pump light fraction petroleum derivatives, solvents, thinners, highly concentrated or organic acids, consult Jabco "Chemical Resistant Table" F.3031 for Proper body materials and impeller compounds. If corrosive fluids are handled, pump life will be prolonged if flushed with water after each use or after each work day.
7. **PRESSURES**—Consult Head Capacity Table for recommended maximum for continuous operation. If pressures exceeds those shown, consult the factory.
8. **TEMPERATURES**—Neoprene 45° - 180° F. Nitrile 50° - 180° F.
9. **FREEZING WEATHER**—Drain unit by loosening end cover.
10. **GASKET**—Use a standard pump part. Thicker gasket will reduce priming ability. A thinner gasket will cause the impeller to bind. Standard gasket is .010" thick.
11. **SPARE PARTS**—To avoid costly shut downs, keep a JABSCO Service Kit on hand. 90023-0001

**HEAD CAPACITY TABLE**

TOTAL HEAD		500 RPM		1160 RPM		1750 RPM		2100 RPM		2450 RPM		3000 RPM		3600 RPM	
PSI (Kg/sq cm)	Ft. of Water (Meter)	GPM (L/Min)	HP	GPM (L/Min)	HP	GPM (L/Min)	HP	GPM (L/Min)	HP	GPM (L/Min)	HP	GPM (L/Min)	HP	GPM (L/Min)	HP
4.3 (.3)	10 (3)	1.2 (4.5)	1/12	2.6 (9.8)	1/6	3.9 (14.8)	1/6	4.6 (17.7)	1/4	5.2 (19.6)	1/4	6.1 (23)	1/4	6.9 (26.1)	1/3
8.7 (.6)	20 (6)	1.1 (4)	1/12	2.4 (10.5)	1/6	3.6 (13.6)	1/6	4.3 (16.2)	1/4	4.8 (18)	1/4	5.6 (21.1)	1/4	6.5 (24.9)	1/3
13.0 (.9)	30 (9)	.8 (3)	1/12	2.1 (7.8)	1/6	3.1 (11.7)	1/6	3.8 (14.4)	1/4	4.2 (15.9)	1/4	5.1 (19.2)	1/3	5.9 (22.3)	1/3
17.3 (1.2)	40 (12)			1.7 (6.4)	1/6	2.6 (9.8)	1/6	3.2 (12.1)	1/4	3.7 (13.9)	1/4	4.5 (16.9)	1/3	5.2 (19.6)	1/3
21.6 (1.5)	50 (15)							2.5 (9.3)	1/4	3.0 (11.3)	1/4	3.8 (14.4)	1/3	4.5 (16.9)	1/3

NOTE: Progressively longer life may be expected as operating pressures and speeds are reduced. Factory Application Engineering assistance suggested for operation in light shaded area and recommended for heavy shaded area. Capacitor type motor recommended. Table shows approximate Head-Flow for new pump in U.S. gallons per minute.

**JABSCO PRODUCTS** **ITT**

## SERVICE INSTRUCTIONS

**Impeller Replacement:** Remove end cover screws, end cover and gasket. Grasp impeller hub with water pump pliers and pull straight out of body. Lubricate impeller bore. With rotary motion, begin putting impeller in body bore. Once started, line up impeller screw with slot in shaft and push impeller straight into body. Lubricate face of impeller, install gasket, end cover, and secure with end cover screws.

**Major Repair:** Follow steps outlined above to remove impeller. Remove outer bearing seal, remove bearing to body retaining ring. Pressing on impeller end of shaft, remove shaft and bearing assembly. Remove inner bearing seal. Remove slinger from inside bearing housing. Remove cam and wearplate from impeller bore. Clean permatex off of cam top. Remove seal and "O" ring. Use care not to scratch or mar "O" ring groove or seal bore. Supporting bearings inner race, press shaft through bearing.

## ASSEMBLY

Press bearing on shaft. Use care to support inner race of bearing. Drop slinger into bearing bore. Lubricate inner bearing seal with water pump grease, or equivalent, and press into body bearing seal bore with lip facing away from bearing. Insert slotted end of shaft into bearing bore, aligning slinger on shaft, and pressing on bearing outer race, press bearing and shaft assembly into bore. Install bearing to body retaining ring in body groove with flat side toward bearing.

Lubricate outer bearing seal with grease and press into bore until flush with body. Install seal in place, using care to protect lip from burrs or protrusions on shaft. Lip of seal must face impeller bore. Place "O" ring in recess between lip seal and body. Install wearplate and cam assembly. (Permatex top of cam and cam screw threads, tighten cam screw making sure cam is flush with end cover surface.)

Replace impeller, gasket and end cover as outlined above.

## EXPLODED VIEW

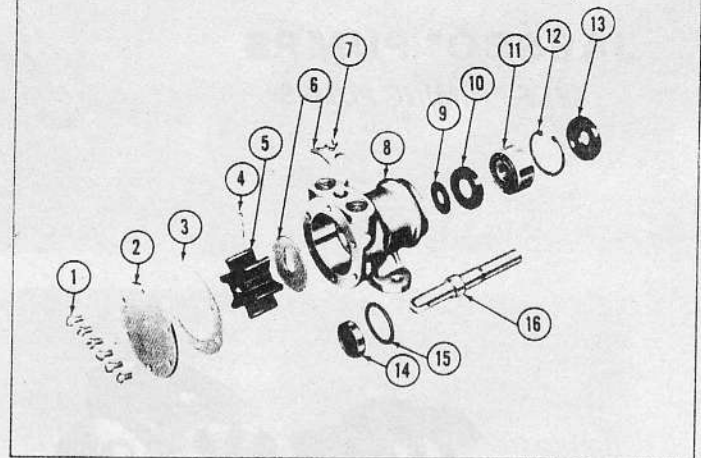

## PARTS LIST

Key	Description	Part Number	Qty. Req.
1	Screw (End Cover)	91002-0010	6
2	End Cover	12066-0000	1
3	*Gasket	1189-0000	1
4	*Screw (Impeller)	91009-0050	1
5	*Impeller - Neoprene	4528-0001	1
6	Nitrile	4528-0003	
7	Wearplate & Cam Assembly	4271-0000	1
8	Screw (Cam)	91002-0030	1
9	Body	2767-0000	1
10	Slinger	1051-0000	1
11	Bearing Seal (Inner)	1041-0000	1
12	Ball Bearing	92600-0080	1
13	Retaining Ring (Brg. to Body)	91700-2520	1
14	Bearing Seal (Outer)	1039-0000	1
15	*Seal (Shaft)	92700-0110	1
16	*"O" Ring	92000-0560	1
	Shaft	1053-0000	1
	Service Kit - Neoprene	90023-0001	
	Nitrile	90023-0003	

\*Parts supplied in Service Kit

## DIMENSIONAL DRAWING

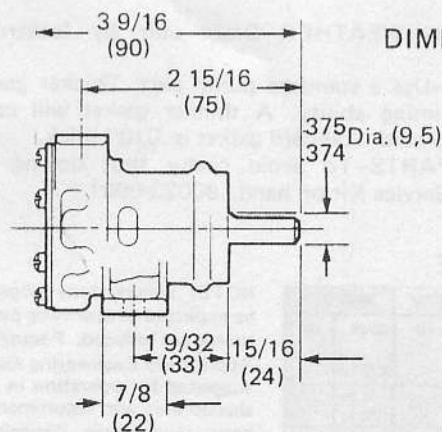

(MILLIMETER EQUIVALENTS)

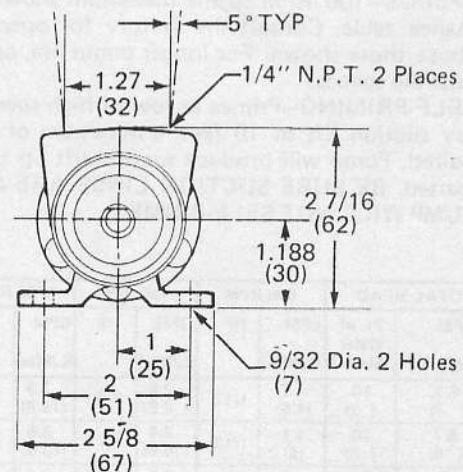

# JABSCO PRODUCTS **ITT**

A Unit of International Telephone and Telegraph Corporation, 1485 Dale Way, Costa Mesa, California 92626  
Telephone: (714) 545-8251