



23870 Diesel Refuelling Pump

2/00

23870 12/24V Fuel Transfer Pump

Features

- Faster refuelling - 35 litres/minute (9.5 U.S.GPM)
- High head capability - 6 metres (19 feet.)
- Self priming up to 2.8 metres (9 feet.)
- Vibration tested
- IP55 protected motor
- Full range of installation accessories
- Customised kits for OEM customers

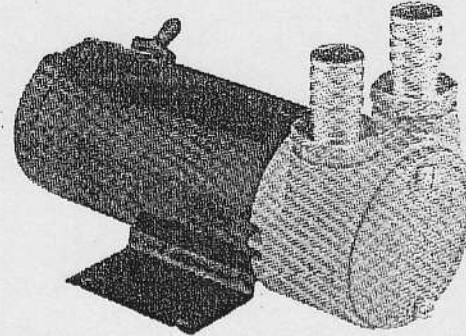

Typical Applications

- Designed for refuelling small sizes diesel powered vehicles [typical tank sizes up to 200 litres (50 U.S. gallons)] from drums.
- Suitable for mounting to the following equipment: Excavators, Cranes, Road rollers (compactors), Pavers, Agricultural machines, Generators, Helicopters.
- Suitable for diesel fuel, Kerosene, Paraffin, Hydraulic oils, Oils up to 150 centi Stokes (750 Saybolt Universal) viscosity.

Specifications

- Temperature Range** : -30°C to +40°C (-22°F to +104°F)
- Pump Body** : Aluminium
- Rotor** : Vectra
- Vanes** : PTFE Filled Ryton
- Shaft** : Steel
- Seal** : Nitrile Lip Seal
- Ports** : Vertical 1/2" BSP or 19mm hose adaptors (3/4")
- Motor** : 12V or 24V DC permanent magnet, corrosion resistant IP55 protected
- Duty** : 45 mins @ +20°C (68°F)
35 mins @ +30°C (86°F)
25 mins @ +40°C (108°F)

Model Range

Model number	Description
23870-2200	1/2" BSP parallel internal ports, 12v DC, switch
23870-2300	1/2" BSP parallel internal ports, 24v DC, switch
23870-1200	19mm (3/4") O/D Hose ports, 12v DC, switch, fuse
23870-1300	19mm (3/4") O/D Hose ports, 24v DC, switch, fuse
23870-1600	19mm (3/4") O/D Hose ports, 24v DC, switch, fuse, check valve, suction strainer
Accessories	
23533-1000	Straight Hose Adaptors
23533-1100B	Straight Hose Adaptors (Kit of 2 including sealing washers)
X5020-003	90° Hose Adaptors
23735-0010B	Check Valve kit
23736-0000B	Foot Valve kit
23732-0000	Suction strainer 300 micron
23531-0001G	Hose - 19mm (3/4") bore - per metre

WARNING Explosion hazard. Do not pump gasoline, solvents, thinners or other flammable liquids. To do so can cause an explosion resulting in injury or death.



23870 Diesel Refuelling Pump

2/00

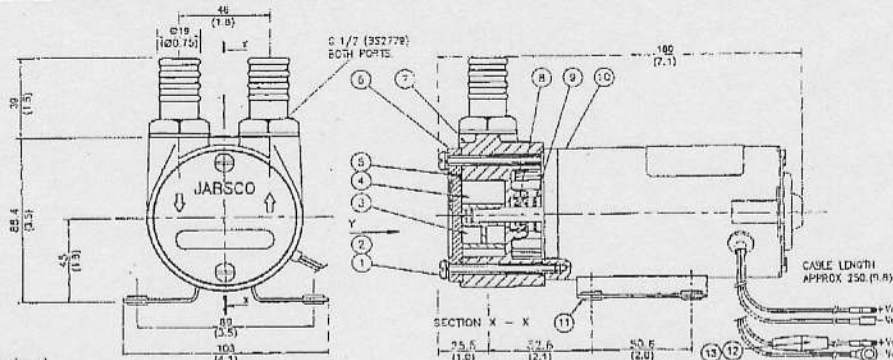

Dimensions in mm (inches)

Parts List

Key	Description	Qty	Part No.
1	Screw	2	X3002-167F
2	Spring washer	2	SP1602-0240
3	Rotor*	1	45714-0000
4	Vane*	5	45716-0100
5	O-Ring*	1	X1990-131
6	Endcover	1	23875-0050
7	Body	1	23874-2050
8	Seal*	1	SP2701-52
9	Slinger*	1	6342
10	Motor	12 Volt	1 98012-9235
		24 Volt	1 98012-9236
11	Grommet	4	SP2900-12
12	Fuse Cap	1	SP2006-0053B
13	Fuse	12V / 10A	1 SP2005-0120B
		24V / 20A	1 Y5292-02
Service kit contains items marked *			SK399-0101

Note

All performance information is based on diesel fuel at 20°C (68°F). On production product, this may vary by up to 10%. Maximum recommended total head of diesel fuel is 6 metres.

Safety

Do not use for pumping petrol, gasoline or products with a flash point below 37°C (99°F). Do not dry run.

Performance

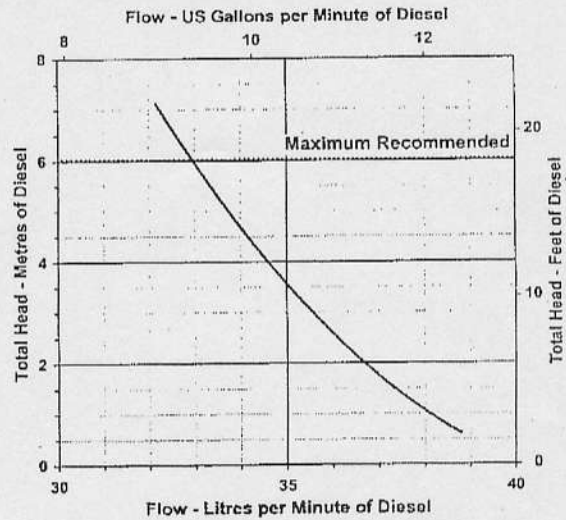

Current Draw 12V = 15 Amps @ 3m head
24V = 7 Amps @ 3m head

Maximum Current 12V = 20 Amps
24V = 10 Amps

Jabsco



ITT Industries

USA

Jabsco
1485 Dale Way
Costa Mesa
CA 92628-2158

Tel : +1 714 545 8251
Fax : +1 714 957 0609

UK

Jabsco
Bingley Road
Hoddesdon
Hertfordshire, EN11 0BU

Tel : +44 (0) 1992 450 145
Fax : +44 (0) 1992 467 132

GERMANY

Jabsco GmbH
Oststrasse 28
22844 Norderstedt

Tel : +49 (0) 40 53 53 73 0
Fax : +49 (0) 40 53 53 73 11

Warranty: All products of the company are sold and all services of the company are offered subject to the company's warranty and terms and conditions of sale, copies of which will be furnished upon request. The information provided herein is for guidance only, it does not constitute a guarantee of the performance or specification of any individual product or component.

43010-0022

Copyright 2000 ITT Industries - Jabsco