

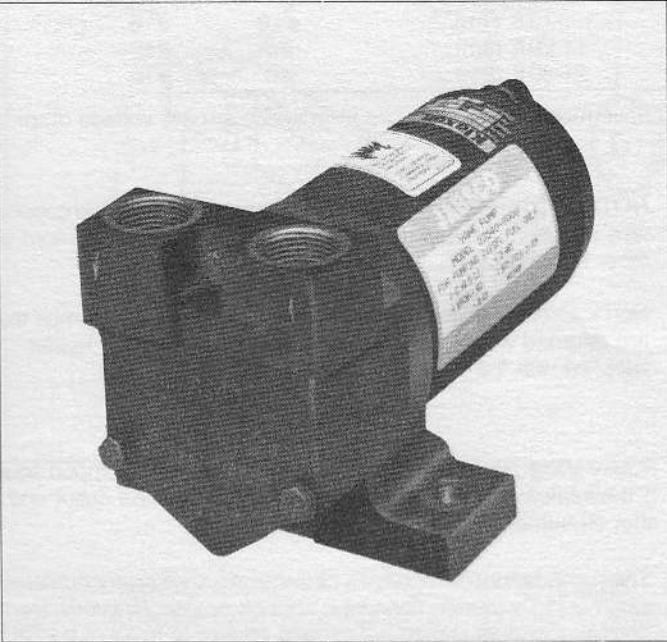

Models 23540-9000 23540-9100



ROTARY VANE PUMP FEATURES

- Body:** Cast Iron
- Ports:** 3/4" IPT
- Vanes:** Bronze
- Rotor:** Brass
- Shaft:** Steel
- Bearings:** Sealed Ball Bearings
- Seal:** Lip (Nitrile)
- Motor End Bracket:** Aluminum
- Motor:** Permanent Magnet
Intermittent Duty (30 min.)
- Height:** 5 7/8" (147mm)
- Length:** 8 15/32" (215mm)
- Width:** 5" (127mm)
- Weight:** 11 lbs. (5 kg)

Models 23540-9000, 23540-9100

⚠ MOTOR WARNING

MOTOR CAN SPARK.
EXPLOSION & DEATH
CAN OCCUR.

DO NOT USE WHERE
FLAMMABLE VAPORS
ARE PRESENT.

**WARNING: DO NOT USE TO
PUMP GASOLINE OR
FLAMMABLE LIQUIDS.**

MODELS AVAILABLE

23540-9000	12 Vdc
23540-9100	24 Vdc

APPLICATION

The Jabsco Rotary Vane pump is ideal for transferring diesel fuel. The brass rotor and bronze vanes are not affected by petroleum products. It is self-priming with a suction lift of up to ten feet and can pump against a discharge head of up to ten feet.

NOTICE: Do not pump water or corrosive fluids. Do not pump oils with a viscosity greater than SAE 10W. Pump and/or motor damage may result.

INSTALLATION

The pump must be mounted in a dry location positioned horizontally – the motor is not waterproof and must not be submerged. SELECTION OF A COOL, VENTILATED location will generally extend pump motor life. The pump may be mounted at 60 degree increments on the bearing house to allow plumbing connections as needed.

PLUMBING CONNECTIONS

Pumps ports are tapped with 3/4" NPT threads. Use rigid plumbing or flexible hose that does not kink when bent and with sufficient wall thickness to prevent collapse when used on suction side of pump. Plumbing should be routed so that some fluid will be retained in pump body to wet the rotor and vanes. Wetting the rotor and vanes aids in priming. Use a strainer on the intake if debris or solids are present in the fluid being pumped. ALL plumbing connections must be airtight to enable fast priming.

PSI	TOTAL HEAD		CAPACITY	
	FEET	METRES	GPM	l/MIN
2,0	5	1,5	12.2	46
4,0	10	3,0	11.9	45

Table shows approximate Head-Flow for new pump. Performance based on diesel fuel S.G. .85.

ELECTRICAL CONNECTIONS

Connect black wire to negative (-) terminal of battery. The red wire should run to an overload protected switch or circuit breaker, with a wire from switch or breaker to positive (+) terminal of battery. Motor rotation is counter clockwise looking at shaft end of motor. Use proper wire size as determined by wire table elsewhere on this sheet. Should fuse blow or breaker trip, replace with same size fuse or reset breaker after determining reason for blown fuse or breaker trip.

WIRING DIAGRAM

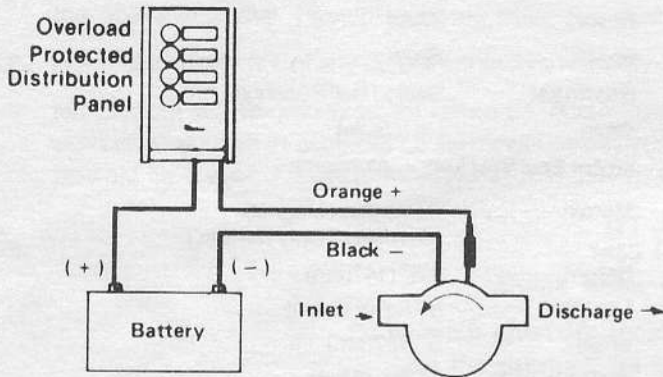

MODELS	VOLTAGE	AMP DRAW	RECOMMENDED FUSE SIZE
23540-9000	12 Vdc	15	20 Amp
23540-9100	24 Vdc	7.0	10 Amp

RECOMMENDED MINIMUM WIRE SIZES

CONNECTION LENGTH BETWEEN BATTERY AND MOTOR	12V	24V
1-10 ft. (3m)	#10	#16
11-20 ft. (6m)	#6	#12
21-30 ft. (9m)	#6	#10

Above recommendations are for a maximum 3% voltage drop.

NOTICE: To prevent motor damage, use only multi-strand copper wire in size recommended. DO NOT use ordinary lamp cord or other substitutes.

NOTICE: No warranty consideration will be given to pumps that are returned without the properly sized fuse and fuse holder supplied with the pump.

OPERATION

Rotary Vane pumps must NOT be run dry, as the pumped liquid is the lubricant for the rotor and vanes. Observe the outlet and shut off pump as soon as liquid stops flowing.

The pump cannot run against a closed outlet such as encountered when using a garden hose type shut-off nozzle. Pressure for normal operation should not exceed 10 feet of head (4.3 PSI). Excessive pressures will cause fuse to blow.

Temperature of pumped liquid may be in the range of -22° - 86°F (-30° - 30°C). Higher temperature will reduce motor run time. Diesel flash point approx. 150°F (66°C).

DO NOT OPERATE PUMP ABOVE THIS TEMPERATURE.

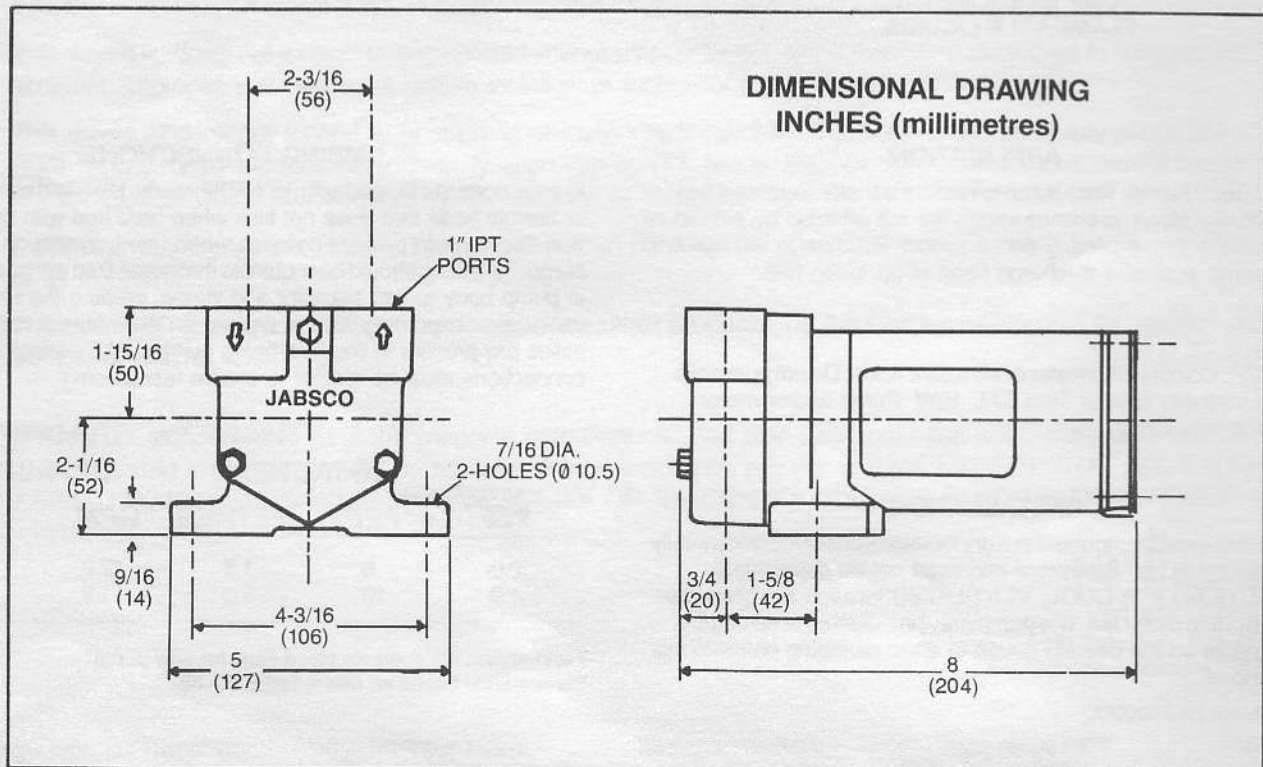

EXPLODED VIEW

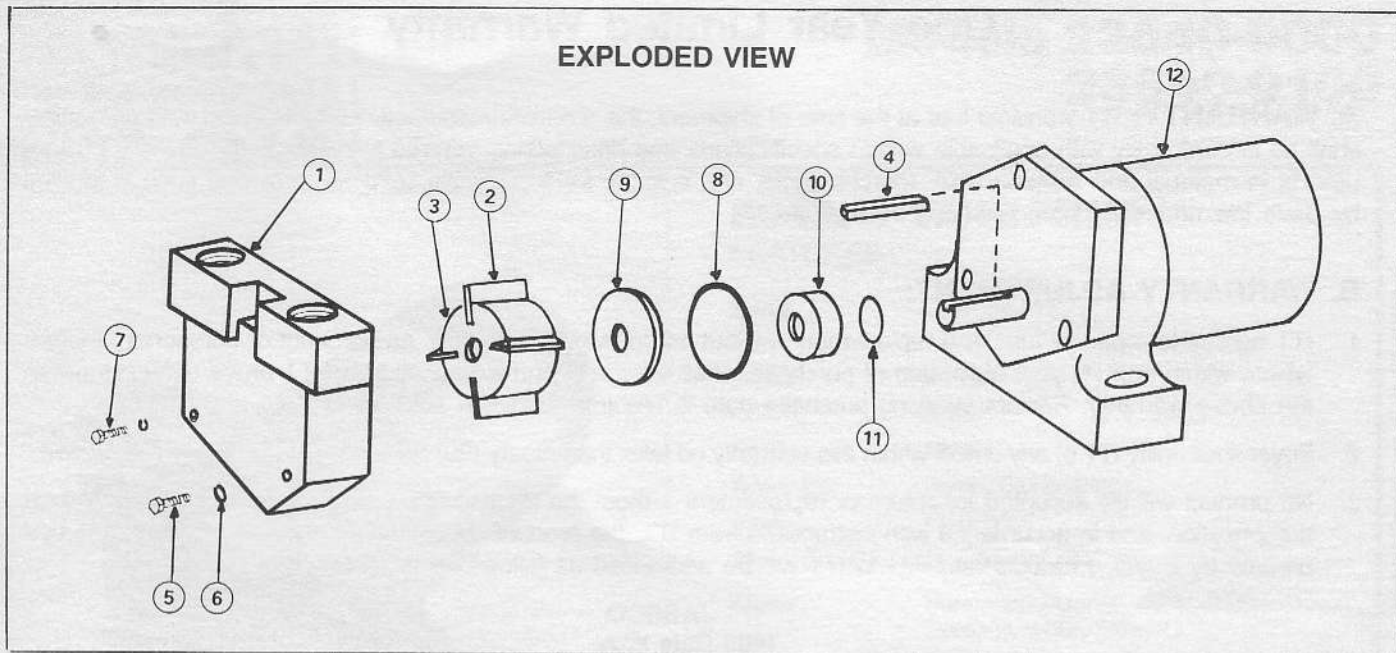

KEY	PART NUMBER	DESCRIPTION	QTY. REQ.	
			-9000	-9100
1	23544-9000	Body	1	1
2*	23183-0000	Vanes	4	4
3	23542-0000	Rotor	1	1
4	91402-0304	Key	1	1
5	18753-0159	Hex Bolt	2	2
6	18753-0161	Lock Washer	3	3
7	18753-0160	Hex Bolt	1	1
8*	18753-0162	O-Ring	1	1
9	23546-0000	Wear Plate	1	1
10*	92701-0504	Seal	1	1
11	18753-0163	O-Ring/Slinger	1	1
12	23547-0000	Motor 12 Vdc	1	
	23547-0100	Motor 24 Vdc		1
	90388-0000	Service Kit		

* Parts contained in Service Kit.

DISASSEMBLY

1. Disconnect pump from electrical supply.
2. Remove pipework from pump and pump unit from its mounting.
3. Remove the 3 hexagon screws and spring washers holding the body to seal housing.
4. Partially withdraw body then push vanes into rotor, hold in position and remove body.
5. Mark the ends of the vanes and the end of rotor to ensure that the vanes will be returned to their respective slots in the rotor.
6. Vanes must be replaced when width has reduced to 11mm (dimension when new: 13mm).
7. Withdraw rotor from shaft and remove woodruff key.
8. Remove O-ring and backplate from motor end bracket.
9. To replace seal or motor brushes, remove 2 hexagon screws retaining motor end shield and shell to seal housing.
10. Carefully withdraw end shield using small levers. Motor shell can now be parted and removed from the seal housing. CAUTION: The motor magnets will attract the armature back into the shell unless completely removed. Avoid contamination of the magnets by swarf or other metallic objects.
11. Remove bearing retaining ring and withdraw armature assembly. Inspect seal for wear and only remove if necessary.

MAINTENANCE

Check wires and connections to be sure corrosion is not adding additional resistance to the motor circuit and causing a low voltage condition at the motor. Full voltage should be available to prevent motor damage.

ASSEMBLY

1. Fit new seal if required.
2. Grease tip of seal and insert armature shaft and bearing, fit retaining ring.
3. Clean inside of shell and remove any foreign particles from magnets.
4. Fit motor shell. Alignment marks on shell and top of motor end bracket *must be in line*.
5. Fit new brushes if required.
6. Push brushes into carrier against springs, hold in position. Ensure waved washer is in bottom of bearing bore and re-fit end shield over bearing. Alignment marks on motor shell and end shield *must be in line*.
7. Insert the 2 hexagon bolts through end shield and shell. Care must be taken to align the bolts centrally between the magnets.
8. Clean both faces of back plate and fit with chamfered face against seal housing.
9. Place woodruff key in shaft, clean rotor and O-ring and fit. Chamfered end of rotor bore must be against backplate.
10. Replace vanes into their respective slots. If new vanes are fitted radiused edges must be facing outwards.
11. Clean face and bore of body and assemble over rotor. Secure with hexagon bolts and spring washers.

One Year Limited Warranty

A. WARRANTY: ITT warrants that at the time of shipment, the products manufactured by ITT and sold hereunder shall be in conformity with applicable written specifications and descriptions referred to or set forth herein, free from defects in material and workmanship, merchantable, and suitable for a particular purpose, provided such is implied by State law under the circumstances of this sale.

B. WARRANTY ADJUSTMENT:

1. ITT agrees to repair or furnish a replacement for, but not to remove or install, any product or component thereof which, within one (1) year from date of purchase, shall upon test and examination by ITT prove defective within the above warranty. Receipt verifying purchase date is required to obtain adjustment.
2. Buyer shall notify ITT of any defect within this warranty no later than ninety (90) days after the defect is discovered.
3. No product will be accepted for return or replacement without the prior written authorization of ITT. Upon such authorization, and in accordance with instructions from ITT, the product will be returned to ITT, shipping charges prepaid by Buyer. Products returned to ITT will be addressed as follows:

ITT JABSCO
1485 Dale Way
Costa Mesa, California 92626

**Or to such alternate locations as may be designated
on the product, its container, or this sheet.**

Repair or replacement made under this warranty will be shipped prepaid to Buyer.

C. EXCLUSIONS FROM WARRANTY:

1. The foregoing warranty is limited solely as set forth herein and applies only for the period designated above.
2. ITT SHALL NOT BE LIABLE FOR ANY LOSS, DAMAGE, SPECIAL OR CONSEQUENTIAL DAMAGE OF ANY KIND, WHETHER BASED UPON WARRANTY, CONTRACT, NEGLIGENCE, OR STRICT LIABILITY ARISING IN CONNECTION WITH THE SALE, USE, OR REPAIR OF THE PRODUCT.
3. THE MAXIMUM LIABILITY OF ITT IN CONNECTION WITH THIS WARRANTY SHALL NOT IN ANY CASE EXCEED THE CONTRACT PRICE FOR THE PRODUCT CLAIMED TO BE DEFECTIVE OR UNSUITABLE.
4. This warranty does not extend to any product manufactured by ITT which has been subjected to misuse, neglect, accident, improper installation, or use in violation of instructions furnished by ITT.
5. This warranty does not extend to or apply to any unit which has been repaired or altered at any place other than ITT's factory, or by persons not expressly approved by ITT, nor to any unit the serial number, model number, or identification of which has been removed, defaced or changed.
6. Components manufactured by any supplier other than ITT shall bear only that warranty made by the manufacturer of that product.
7. This warranty applies to products defined as "consumer products" by the Consumer Product Warranties Act as from time to time amended.

STANDARD WARRANTY: If the products manufactured and sold hereunder are not Consumer Products, the warranty extended to Buyer shall be as set forth in subparagraphs (a), (b), and (c), EXCEPT THAT ALL EXPRESS OR IMPLIED WARRANTIES OR MERCHANTABILITY OR SUITABILITY FOR ANY PARTICULAR PURPOSE ARE EXCLUDED.

ITT JABSCO

A Unit of ITT Corporation

1485 Dale Way, P.O. Box 2158
Costa Mesa, California 92628-2158
(714) 545-8251

4722035 ITTJABSCO CSMA