

**JABSCO®**

# Models 23540-1200 23540-1300

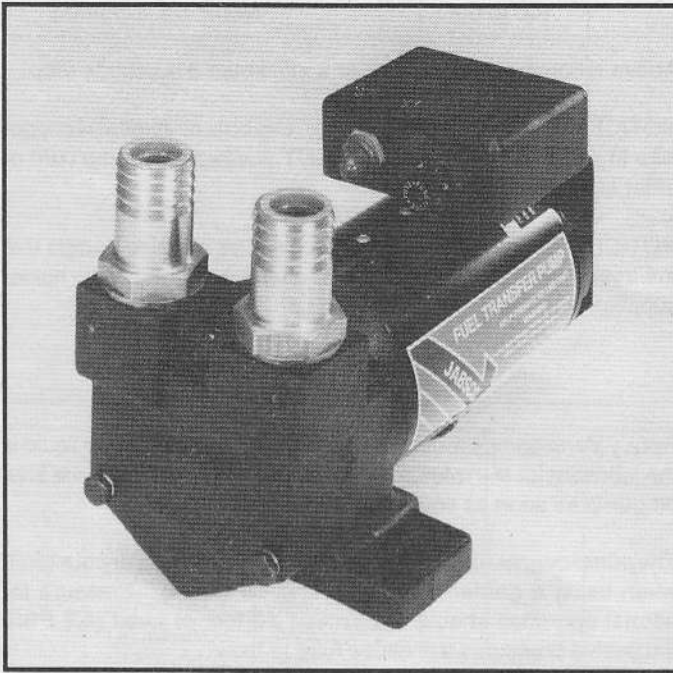

## ROTARY VANE PUMP FEATURES

<b>Body:</b>	Cast Iron
<b>Ports:</b>	1" Hose Barb
<b>Vanes:</b>	Bronze
<b>Rotor:</b>	Brass
<b>Shaft:</b>	Steel
<b>Bearings:</b>	Sealed Ball Bearings
<b>Seal:</b>	Lip (Nitrile)
<b>Motor End Bracket:</b>	Aluminum
<b>Motor:</b>	Permanent Magnet Continuous Duty
<b>Height:</b>	5-3/4" (147mm)
<b>Length:</b>	8-1/2" (215mm)
<b>Width:</b>	5" (127mm)
<b>Weight:</b>	11 lbs (5kg) Approx.

Models 23540-1200 &amp; 23540-1300

## MODELS AVAILABLE

23540-1200	12 Vdc
23540-1300	24 Vdc

### ⚠ MOTOR WARNING



MOTOR CAN SPARK.  
EXPLOSION & DEATH  
CAN OCCUR.  
DO NOT USE WHERE  
FLAMMABLE VAPORS  
ARE PRESENT.

**WARNING: DO NOT USE TO  
PUMP GASOLINE OR  
FLAMMABLE LIQUIDS.**

## APPLICATION

The JABSCO Rotary Vane pump is ideal for transferring diesel fuel. The brass rotor and bronze vanes are not affected by petroleum products. It is self-priming with a suction lift up to ten feet and can pump against a discharge head of up to 20 feet.

**NOTICE:** Do not pump water or corrosive fluids. Do not pump oils with a viscosity greater than SAE 10W (400 SSU). Pump and/or motor damage may result.

## INSTALLATION

The pump must be mounted in a dry location positioned horizontally. The motor is not waterproof and must not be submerged. SELECTION OF A COOL, VENTILATED location will generally extend pump motor life. The pumphead may be mounted at 60 degree increments on the bearing housing to allow plumbing connections as needed.

## PLUMBING CONNECTIONS

Pump's ports are tapped with BSP (British Std. Pipe) threads and fitted with 1" hose barb connectors. Use flexible hose that does not kink when bent and with sufficient wall thickness to prevent collapse when used on suction side of pump. Plumbing should be routed so that some fluid will be retained in pump body to wet the rotor and vanes. Wetting the rotor and vanes aids in priming. Use a strainer on the intake if debris or solids are present in the fluid being pumped. Use JABSCO part no. 18753-0427. ALL plumbing connections must be airtight to enable fast priming.

## PERFORMANCE

PSI	TOTAL HEAD		CAPACITY	
	FEET	METRES	GPM	l/MIN
2.0	5	1,5	12.2	46
4.0	10	3,0	11.9	45

Table shows approximate Head-Flow for new pump.  
Performance based on diesel fuel S.G. 0.85.

## ELECTRICAL CONNECTIONS

Connect black wire to negative (-) terminal of battery. The red wire should run to positive (+) terminal of battery. Motor rotation is counter clockwise looking at shaft end of motor. Use proper wire size as determined by wire table elsewhere on this sheet. Should fuse blow or breaker trip, replace with same size fuse or reset breaker after determining reason for blown fuse or breaker trip.

## WIRING DIAGRAM

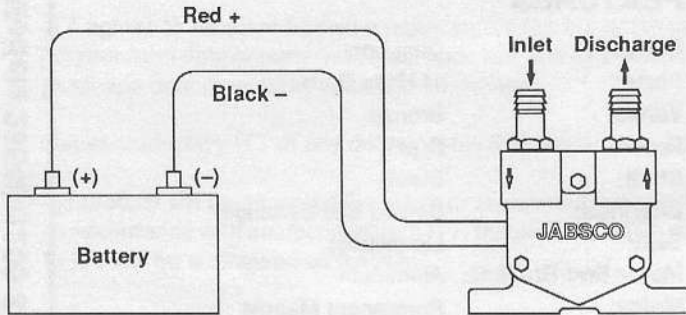

## RECOMMENDED MINIMUM WIRE SIZES

CONNECTION LENGTH BETWEEN BATTERY AND MOTOR	12 V	24 V
	1-10 ft. (3m)	#10
11-20 ft. (6m)	#8	#12
21-30 ft. (9m)	#8	#10
(up to 5m)	4mm <sup>2</sup>	2.5mm <sup>2</sup>

Above recommendations are for a maximum 3% voltage drop.

**NOTICE:** To prevent motor damage, use only multi-strand copper wire in size recommended. DO NOT use ordinary lamp cord or other substitutes.

**NOTICE:** No warranty consideration will be given to pumps that are returned without the properly sized fuse and fuse holder supplied with the pump.

## OPERATION

Rotary Vane pumps must NOT be run dry, as the pumped liquid is the lubricant for the rotor and vanes. Observe the outlet and shut off pump as soon as liquid stops flowing.

The pump cannot run against a closed outlet such as encountered when using a garden hose type shut-off nozzle. Pressure for normal operation should not exceed 10 feet of head (4.3 PSI). Excessive pressures will cause fuse to blow.

Ambient operating temperature: -22° to +86°F (-30° to +30°C). Higher temperature will reduce motor run time. Diesel flash point approx. 150°F (66°C).

**DO NOT OPERATE PUMP ABOVE THIS TEMPERATURE.**

MODELS	VOLTAGE	AMP DRAW	RECOMMENDED FUSE SIZE
23540-1200	12 Vdc	15	20 Amp
23540-1300	24 Vdc	7.0	10 Amp

## DIMENSIONAL DRAWING

INCHES (millimetres)

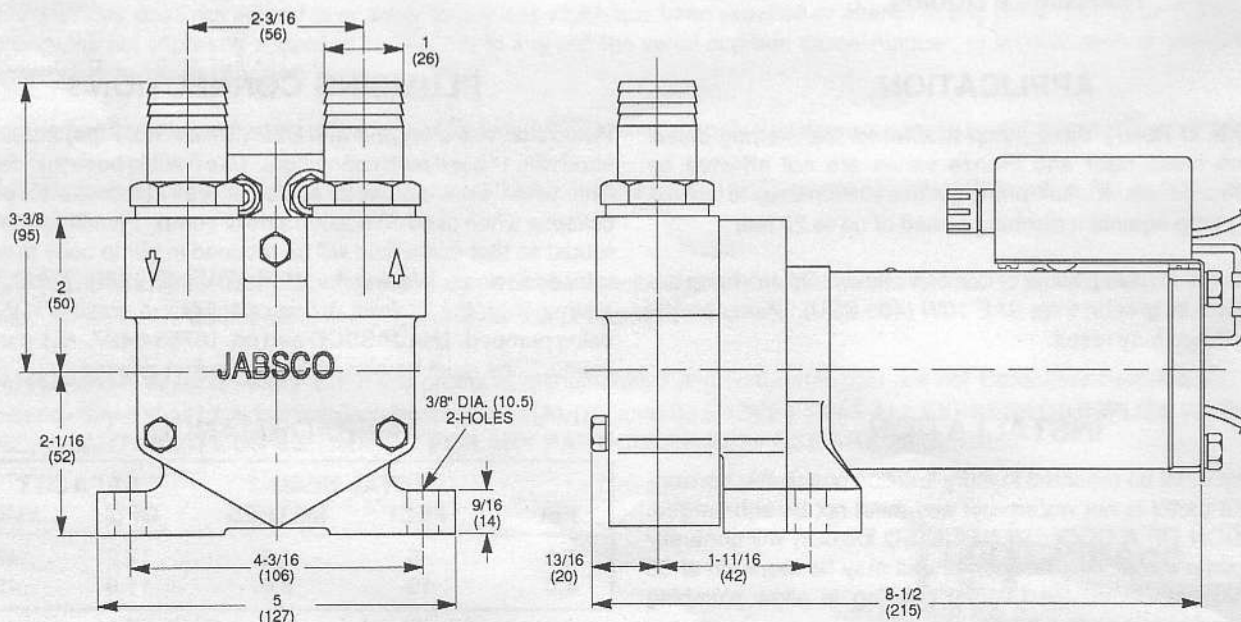

## EXPLODED VIEW

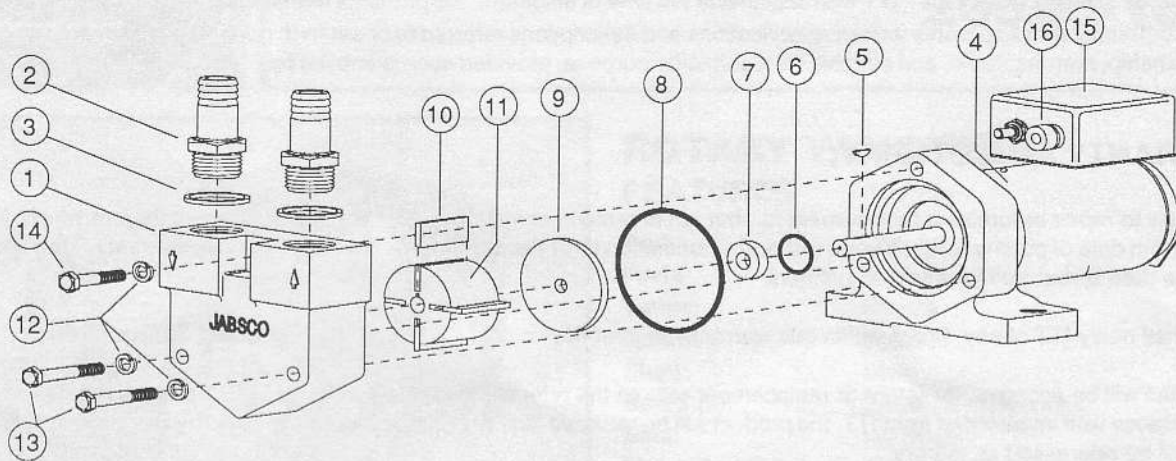

KEY	PART NUMBER	DESCRIPTION	QTY. REQ.	
			-1200	-1300
1	18753-0398	Body	1	1
2	18753-0406	Hose Barb Kit	1	1
3	18753-0409	Washer Kit	1	1
4	18753-0402	Motor 12V	1	
	18753-0403	Motor 24V		1
5	18753-0407	Key	1	1
6	18753-0401	Slinger	1	1
7*	18753-0400	Seal	1	1
8*	18753-0399	O-Ring	1	1
9	18753-0410	Wearplate	1	1
10*	18753-0397	Vane Kit	1	1
11	18753-0396	Rotor	1	1
12	18753-0395	Lock Washer Kit	1	1
13	18753-0394	Bolt Kit	1	1
14	18753-0408	Bolt	1	1
15	18753-0404	Switch 12V	1	
	18753-0405	Switch 24V		1
16	18753-0392	Fuse 12V	1	
	18753-0393	Fuse 24V		1
	90388-0000	Service Kit		1

\* Parts contained in Service Kit.

## MAINTENANCE

Check wires and connections to be sure corrosion is not applying additional resistance to the motor circuit and causing a low voltage condition at the motor. Full voltage should be available to prevent motor damage.

## DISASSEMBLY

1. Disconnect pump from electrical supply.
2. Remove hoses from pump and pump unit from its mounting.
3. Remove the three (3) hexagon screws and lock washers holding the body to seal housing.
4. Partially withdraw body then push vanes into rotor, hold in position and remove body.
5. Mark the ends of the vanes and end of rotor to ensure that the vanes will be returned to their respective slots in the rotor.

6. Vanes must be replaced when width has reduced to 7/16" (11.3mm). Width of vane when new is 1/2" (13mm).
7. Withdraw rotor from shaft and remove woodruff key.
8. Remove O-ring and wearplate from motor end bracket.
9. To replace seal, remove the two (2) hex bolts and lock washers securing the switch mounting bracket to the motor.
10. Remove the two (2) hex bolts holding the motor end bell and housing to the seal housing.
11. Carefully remove end bell from housing. Motor housing can now be separated and removed from the seal housing.  
**CAUTION:** The motor magnets will attract the armature back into the motor housing unless completely removed. Avoid contamination of the magnets by any foreign objects.
12. Remove bearing retaining ring and withdraw armature assembly. Inspect seal for wear and only remove if necessary.

## ASSEMBLY

1. Install new seal if required, pushing evenly into seal housing.
2. Grease lip of seal and insert armature shaft and bearing. Install retaining ring.
3. Clean inside of shell and remove any foreign particles from magnets.
4. Install motor shell. Alignment marks on shell and top of motor end bracket *must be in line*.
5. Push brushes into carrier against springs, hold in position. Ensure wave washer is in bottom of bearing bore and re-fit end bell over bearing. Alignment marks on motor housing and end bell *must be in line*.
6. Insert the 2 hexagon bolts through end bell and housing. Care must be taken to align the bolts centrally between the magnets.
7. Install switch and mounting bracket.
8. Clean both faces of wearplate and install with chamfered face against seal housing.
9. Place woodruff key in shaft, clean rotor and O-ring and install. Chamfered end of rotor bore must be against wearplate.
10. Replace vanes into their respective slots. If new vanes are fitted radiused edges must be facing outwards.
11. Clean face and bore of body and assemble over rotor. Secure with hexagon bolts and lock washers.

# One Year Limited Warranty

**A. LIMITED WARRANTY:** ITT warrants that at the time of shipment, the products manufactured by ITT and sold hereunder shall be in conformity with applicable written specifications and descriptions referred to or set forth herein, free from defects in material and workmanship, merchantable, and suitable for a particular purpose, provided such is implied by State law under the circumstances of this sale.

## **B. WARRANTY ADJUSTMENT:**

1. ITT agrees to repair or furnish a replacement for, but not to remove or install, any product or component thereof which, within one (1) year from date of purchase, shall upon test and examination by ITT prove defective within the above warranty. Receipt verifying purchase date is required to obtain adjustment.
2. Buyer shall notify ITT of any defect within this warranty no later than ninety (90) days after the defect is discovered.
3. No product will be accepted for return or replacement without the prior written authorization of ITT. Upon such authorization, and in accordance with instructions from ITT, the product will be returned to ITT, shipping charges prepaid by Buyer. Products returned to ITT will be addressed as follows:

**ITT JABSCO**  
**1485 Dale Way**  
**Costa Mesa, California 92626-3998**

Or to such alternate locations as may be designated on the product, its container, or this sheet.  
Repair or replacement made under this warranty will be shipped prepaid to Buyer.

## **C. EXCLUSIONS FROM WARRANTY AND LIMITATION OF LIABILITY:**

1. The foregoing warranty is limited solely as set forth herein and applies only for the period designated above.
2. ITT SHALL NOT BE LIABLE FOR ANY LOSS, DAMAGE, SPECIAL OR CONSEQUENTIAL DAMAGE OF ANY KIND, WHETHER BASED UPON WARRANTY, CONTRACT, NEGLIGENCE, OR STRICT LIABILITY ARISING IN CONNECTION WITH THE SALE, USE, OR REPAIR OF THE PRODUCT.
3. THE MAXIMUM LIABILITY OF ITT IN CONNECTION WITH THIS WARRANTY SHALL NOT IN ANY CASE EXCEED THE CONTRACT PRICE FOR THE PRODUCT CLAIMED TO BE DEFECTIVE OR UNSUITABLE.
4. This warranty does not extend to any product manufactured by ITT which has been subjected to misuse, neglect, accident, improper installation, or use in violation of instructions furnished by ITT.
5. This warranty does not extend to or apply to any unit which has been repaired or altered at any place other than ITT's factory, or by persons not expressly approved by ITT, nor to any unit the serial number, model number, or identification of which has been removed, defaced or changed.
6. Components manufactured by any supplier other than ITT shall bear only that warranty made by the manufacturer of that product.
7. This warranty applies to products defined as "consumer products" by the Consumer Product Warranties Act as from time to time amended.

**D. CONSUMER RIGHTS:** This warranty gives you specific legal rights, and you may have other rights which vary from state to state. Some states do not allow exclusion or limitation of damages.

**STANDARD WARRANTY:** If the products manufactured and sold hereunder are not Consumer Products, the warranty extended to Buyer shall be as set forth in subparagraphs (A), (B), and (C), **EXCEPT THAT ALL EXPRESS OR IMPLIED WARRANTIES OR MERCHANTABILITY OR SUITABILITY FOR ANY PARTICULAR PURPOSE ARE EXCLUDED.**

**ITT Jabsco**

ITT Fluid Technology Corporation  
1485 Dale Way, P.O. Box 2158, Costa Mesa, CA 92628-2158  
Tel: (714) 545-8251; Fax: (714) 957-0609  
Bingley Road, Hoddesdon, Hertfordshire EN11 0BU, England  
Tel: 0992-467191; Tlx: 263251 G; Fax: 0992-467132