

JABSCO®

Models 2300-SERIES 6590-SERIES

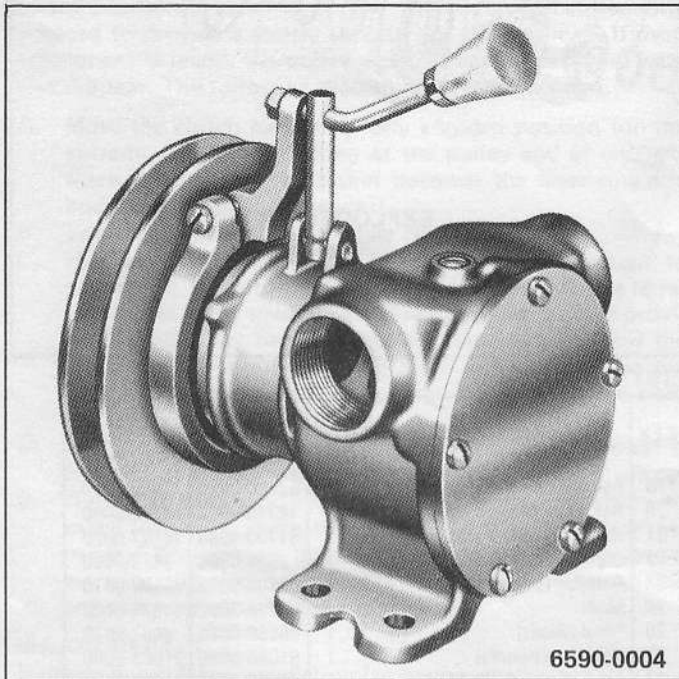

SELF-PRIMING PUMPS MANUAL CLUTCH UNITS

FEATURES

Body:	Bronze
Impeller:	Nitrile Compound
Shaft:	2300 Stainless Steel 6590 Brass
Ports:	2300 - 1" NPT 6590 - 1 1/4" NPT
Seal:	Carbon-Ceramic, Face-Type
Bearings:	Shielded Ball Bearings
Shipping Weight:	2300 - 9 1/2 lbs (4,3 kg) 6590 - 17 lbs (7,7 kg)

MODEL	PORT SIZE	IMPELLER
2300-9005	1"	Nitrile
6590-0005	1-1/4"	Nitrile

Models 2300-SERIES; 6590-SERIES

MARINE: Pumping bilges, Washdowns, Circulating water in bait tanks, Utility dock side pump.

INDUSTRIAL: Circulating and transferring, Velocity-mixing, Pumping machine tool coolants, Return spill, Sump drainage, Chemicals, Pharmaceuticals, Soap, Liquors, Ink, Dyes, Alcohol, Various acids, Tanning Liquors, Glycerine, Brine, etc.

FARMING: Pumping water for stock, Pumping water from shallow wells and cisterns.

PLUMBING & HOME EMERGENCY USE: Pumping out flooded basements, Cesspools, Sumps, Water heaters and water closets, Drains and sinks, Draining fishponds and pools.

PUBLIC UTILITIES AND MUNICIPALITIES: De-watering and draining meter boxes and excavations, Dust control and sampling.

OPERATING INSTRUCTIONS

- NOTICE**—Pump must be mounted to turn in a clockwise direction when looking at the end cover. Failure to install for clockwise rotation can damage clutch.
- DRIVE BELT**—Overtight belt load will reduce pump bearing and clutch face life. 1/2" deflection of belt midway between pulleys is generally considered normal. Use A or B section belt for 2300 Series. Use B section for 6590 Series.
- SPEEDS**—100 RPM to the maximum shown in performance table. Consult factory for operation at speeds above those shown. For longer pump life, operate at lowest possible speed.
- SELF-PRIMING**—Primes at low or high speed. For vertical dry suction lift of 10 feet, a minimum of 800 RPM is required. Pump will produce suction lifts up to 22 feet when wetted. "Be sure suction connections are airtight or pump will not self prime."
- RUNNING DRY**—Unit depends on liquid pumped for lubrication. Do not run dry for more than 30 seconds. Lack of liquid will burn impeller.
- NOTICE**—If pumping light fraction petroleum derivatives, solvents, thinners, highly concentrated or organic acids, consult Jabsco Chemical Resistance Table (which is available upon request from ITT Jabsco) for proper body materials and impeller compounds. If corrosive fluids are handled, pump life will be prolonged if pump is flushed with water after each use or after each work day.
- PRESSURES**—Consult Head/Capacity Table for recommended maximum for continuous operation. Consult factory if pressures might exceed those shown.
- TEMPERATURES**—Neoprene impeller - 45° to 180° F (7° to 82° C). Nitrile impeller - 50° to 180° F (10° to 82° C).
- FREEZING WEATHER**—Loosen end cover screws to drain unit.
- GASKET**—Use standard pump part. Thicker gasket will reduce priming ability - thinner gasket will cause impeller to bind. Standard gasket is 0.010" for 2300 Series and 0.015" for 6500 Series.
- SPARE PARTS**—To avoid costly shutdown, keep a Jabsco Service Kit on hand.

CAUTION: Exposed pulley and belts can cause injury. Install shield around pulleys and belts.

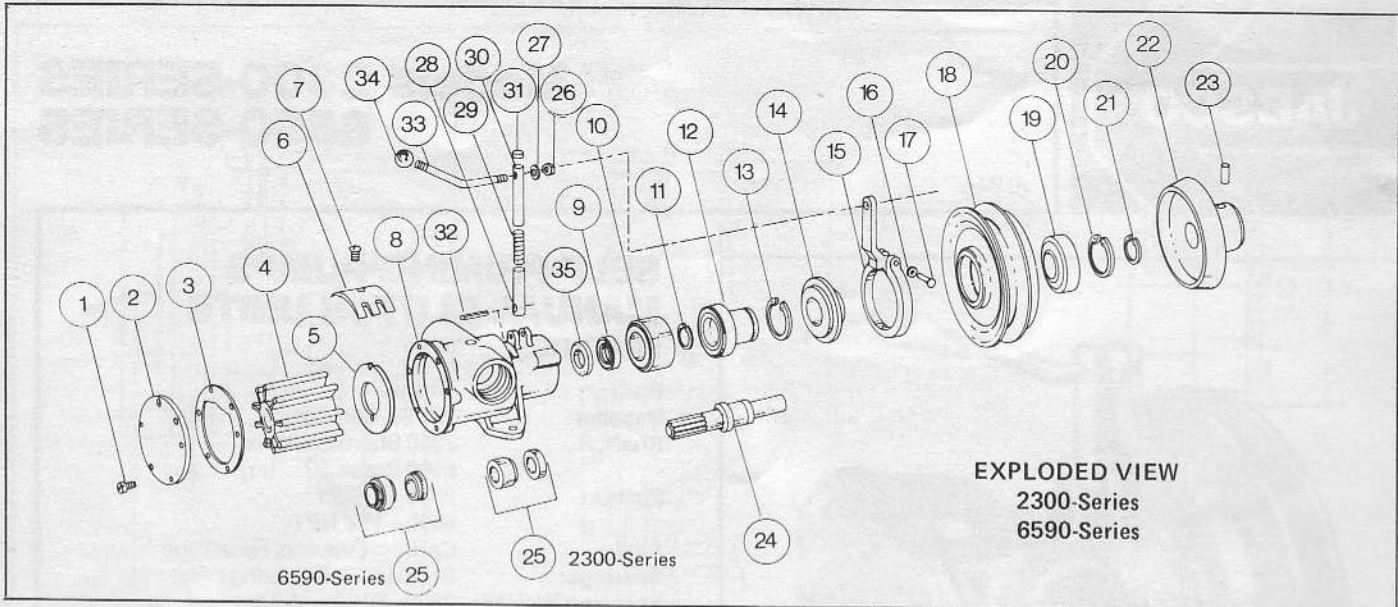

EXPLODED VIEW
2300-Series
6590-Series

PARTS LIST

KEY	DESCRIPTION	QTY REQ	MODEL	
			2300-Series PART NO.	6590-Series PART NO.
1	Screw (End Cover)	6	91003-0010	
2	Screw (End Cover)	5		91005-0040
3	End Cover	1	11831-0000	12062-0000
4	*Gasket (End Cover)	1	890-0000	816-0000
5	*Impeller Neo. Brass Ins.	1	17937-0001	17935-0001
6	Impeller Nit. Brass Ins.		920-0003	836-0003
7	Wearplate	1	4156-0000	2574-0000
8	Cam - Brass	1	934-0000	834-0001
9	Screw (Cam)	1	91004-0090	91005-0040
10	Body	1	798-0030	18753-0118
11	Seal (Brg.)	1	913-0000	817-0000
12	Ball Bearing (Pump)	1	92600-0060	92600-0040
13	Ret. Ring (Brg. To Shaft)	1	18713-0000	18711-0000
14	Body Plug & Engaging Sleeve	1	3855-0000	3856-0000
15	Ret. Ring (Plug to Body)	1	18724-0000	18712-0000
16	Adaptor Ring	1	2290-0000	2471-0000
17	Lever Ring	1	2285-0000	2470-0000
18	Lock Washer (Lever Ring)	1	91602-0060	91602-0060
19	Screw (Lever Ring)	1	91005-0060	91005-0060
20	Clutch Pulley	1	2286-0000	2472-0010

KEY	DESCRIPTION	QTY REQ	MODEL	
			2300-Series PART NO.	6590-Series PART NO.
*19	Ball Bearing (Pulley)	1	92600-0020	92600-0330
*20	Ret. Ring (Brg. to Clutch)	1	18710-0000	18718-0000
*21	Ret. Ring (Brg. to Sleeve)	1	91700-0980	18707-0000
*22	Clutch Cone	1	2584-0000	2473-0000
*23	Roll Pin (Cone)	1	93100-0010	93100-0010
24	Shaft	1	6718-0000	824-0000
25	*Seal (Shaft)	1	96080-0080	6407-0010
26	Hex Nut (Handle)	1	91085-0090	91085-0090
27	Lock Washer (Handle)	1	91602-0080	91602-0080
28	Guide Tube	1	3525-0000	3525-0000
29	Spring (Handle)	1	3528-0000	3528-0000
30	Spring Guide Tube	1	3526-0000	3526-0000
31	Plug (Rubber)	1	3530-0000	3530-0000
32	Roll Pin (Tube)	1	93100-0020	93100-0020
33	Handle (Clutch)	1	2415-0000	2415-0000
34	Knob (Handle)	1	92330-0010	92330-0010
35	Slinger	1		3181-0000
	Clutch Kit (Not Shown)		4377-0000	4387-0000
	Service Kit Neoprene Impeller		90118-0001	90062-0001
	Service Kit Nitrile Impeller		90118-0003	90062-0003

*Parts Supplied with Service Kit.

2300-Series and 6590-Series SERVICE INSTRUCTIONS

IMPELLER REPLACEMENT: Remove end cover and gasket. Pull impeller out by grasping hub with pliers. With a rotary motion in the direction the pump will be turning, push the new impeller into the impeller bore. A light coating of grease in the impeller bore will protect new impeller during initial dry start up. Install gasket and end cover.

SHAFT SEAL REPLACEMENT, 6590 SERIES: Remove end cover, gasket and impeller as outlined above. Loosen cam screw several turns and give it a couple of sharp raps with the handle of the screwdriver to loosen the cam from the impeller bore. Remove the cam screw and cam (clean sealant from cam and impeller bore). Remove wearplate with hooked wire.

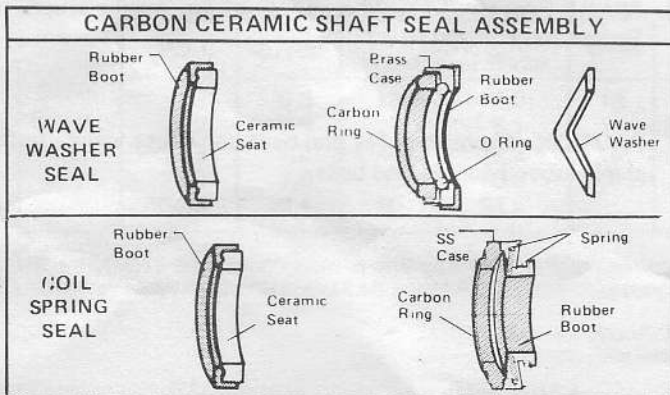

In this pump, either a wave washer seal or coil spring seal may be used. The wave washer is used only if the carbon portion of the seal does not have a coil spring attached.

Using a hooked wire, and taking care not to scratch shaft or seal seat bore, remove all components of seal assembly. Inspect shaft and seal seat bore to be sure sealing surfaces are free of nicks or scratches. Clean shaft surface behind splines to insure proper O-ring seal on shaft. Apply light film of grease on shaft surface behind spline area. Thoroughly clean seal faces (carbon and ceramic) of all grease, oil or particles — this will insure that seal faces will turn freely on startup. Place ceramic seat assembly in body with boot first. Use care not to damage ceramic surface. Be sure ceramic and boot are bottomed squarely in body bore. Slide carbon ring assembly, with carbon facing ceramic, over the shaft and firmly up against the ceramic seat. If carbon portion of seal does not have an integral coil type tensioning spring, slide wave washer over the shaft and against the rubber boot on metal case containing O-ring and carbon. Replace wearplate aligning notch with dowel pin in body. Apply sealant to top surface of cam and cam screw threads and install cam in impeller bore. Snug up but do not tighten cam screw. Replace impeller, gasket and end cover as outlined above. Tighten end cover screws. Tighten cam screw.

SHAFT SEAL REPLACEMENT 2300 SERIES: Refer to major repair instruction.

SERVICE INSTRUCTIONS (Continued)

CLUTCH ADJUSTMENT FOR WEAR (CLUTCH SLIPPAGE):

The Jabsco clutch engages and disengages by means of internal threads in the body plug and external threads on the engaging sleeve. When adjustment is made, the engaging sleeve is "backed out" of the body plug. Therefore, the adjustment is limited to the position beyond which the threads are not sufficiently engaged to provide a sturdy support for the belt load. If over-adjustment is made, the pulley wobbles and causes more wear and slippage. The following procedure is recommended.

- A. Move the clutch handle to fully engaged position (on the extreme left when looking at the pulley end of unit). If there is a rubber ring gasket between the lever ring and body, pry it out and discard it.
- B. Loosen screw (key 17) on lever ring (key 15).
- C. Hold adaptor ring (key 14) in place with a screwdriver to prevent it from turning and simultaneously rotate lever ring to the right, towards the disengaged position, approximately half way between the left hand stop lug and the center line of the pump (the lever ring will slide on the adaptor ring more easily if a screwdriver is used to hold the split in the lever ring apart).
- D. Tighten lever ring screw, and check to see if clutch is engaged when handle is moved to the left as far as it will go.
- E. Repeat if necessary. However, if it becomes necessary to move lever ring more than twice (1-1/2" or 45° from its original position on the adaptor ring) the cone is badly worn and should be replaced to prevent damage to the engaging sleeve and body plug threads.

MAJOR REPAIR

Remove pump from installation for major repair.

CLUTCH REPLACEMENT: Remove roll pin (key 23) from clutch cone (key 22). Using a wheel puller, grip notches in clutch cone and pull it from the shaft. Remove clutch handle (key 33) spring guide tube (key 30) and spring (key 29). The pulley, bearing, engaging sleeve, adaptor ring and lever ring are removed by unscrewing the engaging sleeve from the body plug as follows:

1. Facing the pulley end of the pump, turn lever ring (key 15) counterclockwise (left to the stop lug on body).
2. Loosen screw (key 17) on lever ring.
3. Hold the engaging sleeve in place with a screwdriver placed between shaft and engaging sleeve and simultaneously rotate lever ring clockwise (right) to the opposite stop lug on body.
4. Tighten screw.
5. Repeat above steps until engaging sleeve is unscrewed and pulley assembly comes loose from the pump. Individual parts may be replaced in the pulley and clutch mechanism or the complete clutch may be replaced using clutch kit (4377-0000 for 2300 Series or 4387-0000 for 6500 Series).

NOTE: To assist in repairs the clutch kit contains the adaptor ring, ball bearing and pulley pressed on to the engaging sleeve with retaining rings in place and the lever ring assembled to the adaptor ring. The body plug and engaging sleeve are selective fit and should be replaced as a set. Remove retaining ring (key 13) from body. Remove retaining ring (key 21) from engaging sleeve. Support pulley assembly on adaptor ring and press engaging sleeve out of pulley bearing and adaptor ring. Use the engaging sleeve to remove the body plug by threading the engaging sleeve into the body plug and using a pipe wrench to force the body plug away from the bearing and out of the body. To assemble the clutch kit to the pump, remove the body plug from the engaging sleeve and press it into the bearing bore firmly against ball bearing. Install retaining ring in body with flat side against body plug. Grease threads of body plug. Place assembled pulley, bearing, engaging sleeve and lever ring mechanism over shaft and against body plug. With lever ring in the "up" position, rotate lever ring clockwise to start threads

of engaging sleeve into body plug. Thread engaging sleeve into body plug as follows:

1. Facing pulley end of pump, turn lever ring clockwise (right) to the stop on the body.
2. Loosen Screw on lever ring.
3. Hold engaging sleeve in place with a screwdriver placed between the engaging sleeve and shaft, and simultaneously rotate lever ring counterclockwise (left) to the stop on the body.
4. Tighten screw in the lever ring.
5. Repeat the above steps until engaging sleeve is completely threaded in body plug. With engaging sleeve threaded and bottomed in body plug, loosen screw in lever ring and rotate lever ring clockwise to stop on body. Tighten lever ring screw. Rotate lever ring counterclockwise and hold in place at 15 degrees to the left of top center. Slide clutch cone onto shaft and push it tight against pulley. With pilot hole at 90° to hole in shaft and using pilot hole in clutch cone hub as a guide, drill 3/16" (4.76 mm) diameter hole through the shaft and straight through the clutch cone hub. Insert roll pin into drilled hole. With clutch fully engaged, lever ring should be approximately 30 degrees to the left of top center (facing pulley end of pump). Check clutch engagement and perform any required adjustments using the "clutch adjustment" procedure. Install control handle hardware.

SHAFT & BEARING REPLACEMENT

Remove pump from installation for major repair.

DISASSEMBLY

Remove end cover, impeller, cam, wearplate and seal (Model 6590 Series only) as outlined in "shaft seal replacement" instructions. Remove retaining ring from body. Support body on arbor press platten and press on impeller end of shaft to remove the body plug and bearing/shaft assembly from body. On model 6590 Series, slinger can be removed through drain slot. Model 2300 Series ceramic seal seat may be removed from drain slot. Use a screwdriver to pry inner bearing seal from bearing bore. Model 2300 Series, press seal assembly out of seal bore. Check condition of bearing and shaft. Replace if bearing turns roughly or has grating feel. Replace shaft if worn in seal area or if splines are worn. Remove retaining ring from shaft and press on clutch end of shaft while supporting bearing inner race.

ASSEMBLY

Support inner race of ball bearing, insert clutch drive end of shaft through bearing, press on splined end until bearing is seated firmly against shaft shoulder. Install retaining ring on shaft. Lubricate bearing seal and press into body bearing bore with lip facing impeller end. (Model 6590). Place slinger in drain slot and insert splined end of shaft into bearing bore, through bearing seal and press on outer race of bearing until bearing bottoms firmly against shoulder in body. (Model 6590). Center slinger in drain area. Press body plug into body firmly against bearing. Install retaining ring in body with flat side against body plug. (Model 2300 Series face seal replacement). Install seal seat gasket ring in counterbore of ceramic seal seat. Dip in water and push carefully over shaft splines with gasket side down until it bottoms firmly against shaft shoulder. With carbon face of seal towards ceramic seal seat, locate seal squarely in seal bore and using a tube of suitable diameter to press on outside edge of seal, press seal into seal bore flush with bottom face of impeller bore. Install wearplate, cam, impeller gasket & end cover as outlined in "seal replacement" instructions.

When installing pump, do not overtighten belt. Belt tension is normally considered sufficient when belt can be depressed 1/2" midway between pulleys. Over tight belt can cause wear between clutch cone and pulley.

DIMENSIONAL DRAWING

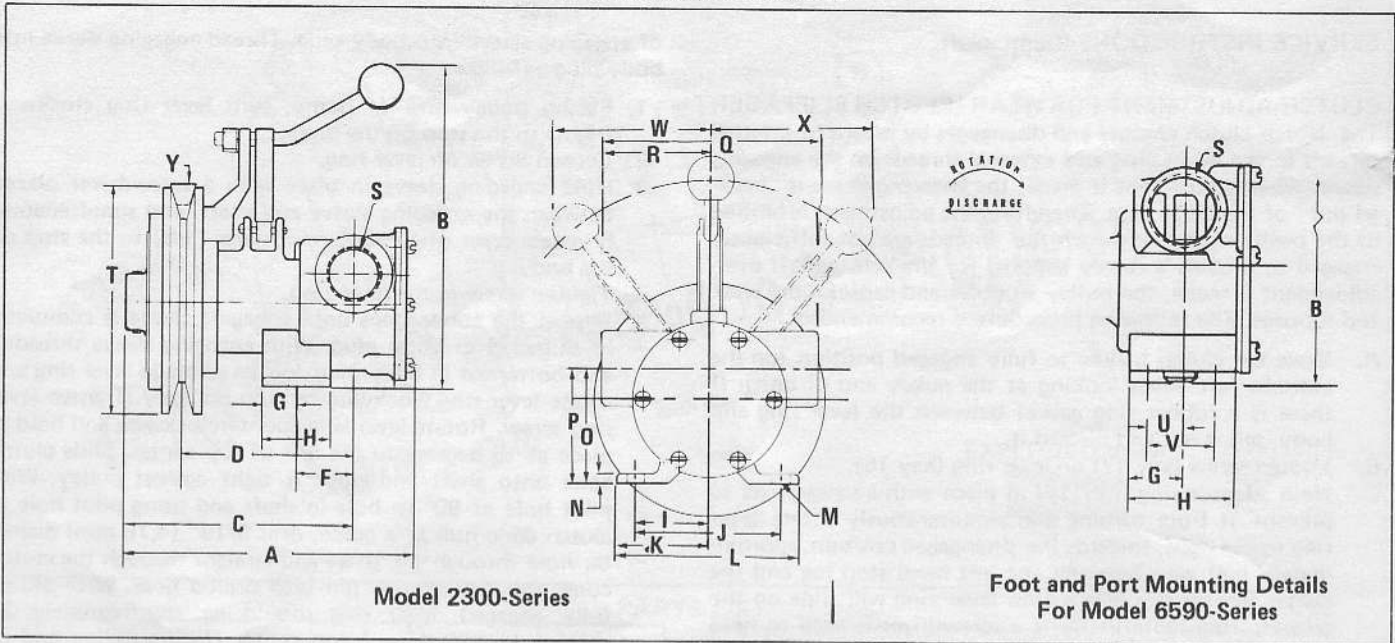

TABULATIONS FOR ABOVE MODELS
Inches (Millimetres)

MODEL	A	B	C	D	E	F	G	H	I	J	K	L	M	N
2300-Series	6-3/8 (162)	7-1/4 (184)	5-1/16 (129)	3-3/4 (95)	—	1-1/4 (32)	3/4 (19)	1-1/2 (38)	1-9/16 (40)	3-1/8 (79)	2 (51)	4 (102)	0.406 DIA (10)	1/4 (6)
6590-Series	8-1/16 (205)	8-1/8 (206)	5-31/32 (152)	4-3/8 (111)	—	—	1-7/32 (31)	2-5/16 (59)	2-1/4 (57)	4-1/2 (114)	2-3/4 (70)	5-1/2 (140)	0.406 DIA (10)	1/4 (6)

MODEL	O	P	Q	R	S (Port Size)	T	U	V	W	X	Y (Drive Belt Size)
2300-Series	1-7/8 (48)	2-1/2 (64)	4-3/4 (121)	2-3/8 (60)	1-11½ NPT	5 DIA (127)	—	—	3-1/2 (89)	3-1/2 (89)	A or B
6590-Series	2-9/16 (65)	3-13/16 (97)	5-7/8 (149)	2-15/16 (75)	1¼-11½ NPT	6 DIA (152)	13/16 (21)	1-1/2 (38)	4 (102)	4-5/8 (117)	B

HEAD / CAPACITY TABLE

	TOTAL HEAD				500 RPM			1160 RPM			1750 RPM			2100 RPM		
	P.S.I.	kg/cm ²	Ft. of Water	Metres of Water	GPM	ℓ/Min	HP	GPM	ℓ/Min	HP	GPM	ℓ/Min	HP	GPM	ℓ/Min	HP
2300-Series	4.3	0,3	10	3,0	5.8	22,0	1/4	14.9	56,4	1/3	23.3	88,2	3/3	28.3	107,1	3/4
	8.7	0,6	20	6,1	5.4	20,4	1/4	14.2	53,7	1/2	22.5	85,2	3/4	27.4	103,7	1
	17.3	1,2	40	12,2	4.1	15,5	1/4	11.0	41,6	1/2	19.9	75,3	3/4	24.2	91,6	1
	26.0	1,8	60	18,3				8.3	31,4	3/4	16.1	60,9	1	20.0	75,7	1-1/2
	34.6	2,4	80	24,4										14.4	54,5	1-1/2

	TOTAL HEAD				500 RPM			1160 RPM			1750 RPM		
	P.S.I.	kg/cm ²	Ft. of Water	Metres of Water	GPM	ℓ/Min	HP	GPM	ℓ/Min	HP	GPM	ℓ/Min	HP
6590-Series	4.3	0,3	10	3,0	18	68,1	1/2	41	155,2	1	62	234,7	1-1/2
	8.7	0,6	20	6,1	17	64,3	1/2	40	151,4	1	60	227,1	1-1/2
	17.3	1,2	40	12,2	14	53,0	1/2	37	140,0	1-1/2	55	208,2	2
	26.0	1,8	60	18,3				32	121,1	1-1/2	50	189,3	2
	34.6	2,4	80	24,4							44	166,5	3

THE PRODUCTS DESCRIBED HEREIN ARE SUBJECT TO THE JABSCO ONE YEAR LIMITED WARRANTY, WHICH IS AVAILABLE FOR YOUR INSPECTION UPON REQUEST.

ITT Jabsco

ITT Fluid Technology Corporation

1485 Dale Way, P.O. Box 2158, Costa Mesa, Ca 92628-2158; Tel: (714) 545-8251; Fax: (714) 957-0609
Bingley Road, Hoddesdon, Hertfordshire EN11 OBU, England; Tel: 0992-467191; Tlx: 26351 G; Fax: 0992-467132