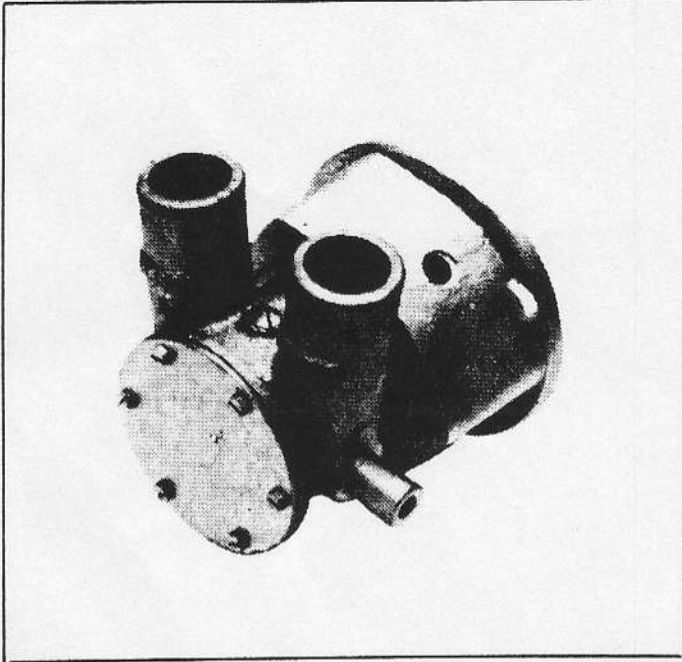

JABSCO**Model 22740-0351**

Model 22740-0351

**PUMP
FEATURE**

Pump Body: Bronze
Impeller: JabSCO Neoprene Compound
Shaft: 316 Stainless Steel
Shaft Seal: Buna N Lip Seal
Ports: 1 1/4" Hose Barb
Weight: 4 lb. 6 oz. (1,95 kg)

APPLICATION

Marine Engine Cooling
 For Engine Models:

Volvo V-8 (Chevrolet Block)

Alaska Marine Engine
 4219, 4276DT, 6414DT

Hardin Marine

Indmar Marine

Kaama

INSTALLATION

This pump has been designed to mount inside the crankshaft pulley of the Volvo V-8 (Chevrolet 350 CI block) engines. Other engines listed have the pump mounted on adaptor flanges. The maximum engine speed of the pump is 5200 RPM. The maximum recommended discharge head is 20 feet (6 m) or 9 PSI. When the pump is installed to operate at maximum RPM, the installation design must minimize suction head (a high speed scoop on the hull fitting is recommended).

For installations where the pump is to be mounted on the crankshaft pulley, remove all belts that run off the crankshaft pulley. Remove bolts securing the crankshaft to the vibration dampener. This pump may be secured to pulley/dampener by using either Volvo mounting studs (Volvo part no. 826500-1) or 3/8-24 x 2-3/4" socket head (allen type) cap screw. If mounting with Volvo studs, install studs into vibration dampener.

Install pulley over studs on the vibration dampener and place the pump in the pulley. Make sure that the locator bosses on the vibration dampener are properly aligned with the locator bosses in the pulley and the holes in the pump bearing housing. Install flat washers, lock washers and 5/16-24 nuts on studs and tighten evenly. The flat washers should overlap both the pump bearing housing and the pump bearing outer race.

If mounting with caphead screws, remove pump end cover and align flat in end cover flange with a mounting hole in bearing housing. Position pump in pulley against vibration dampener and install first cap screw. Rotate pump body in 120° increments to install remainder of screws.

Replace all belts on the crankshaft pulley. Attach a torque arm/bracket from the torque arm boss on the pump to a convenient bolt on the engine. This torque arm must not impose a side force on the pump assembly. This could shorten bearing life in high RPM service.

Attach and double clamp the intake and discharge hoses (1-1/4" ID) to the pump ports. Be sure the hoses do not impose a side force on the pump assembly. This could shorten pump bearing life in high RPM service. Hoses should be flexible and supported by the engine (not the pump). Start the engine and run at low speeds. Check the installation for leaks or vibration.

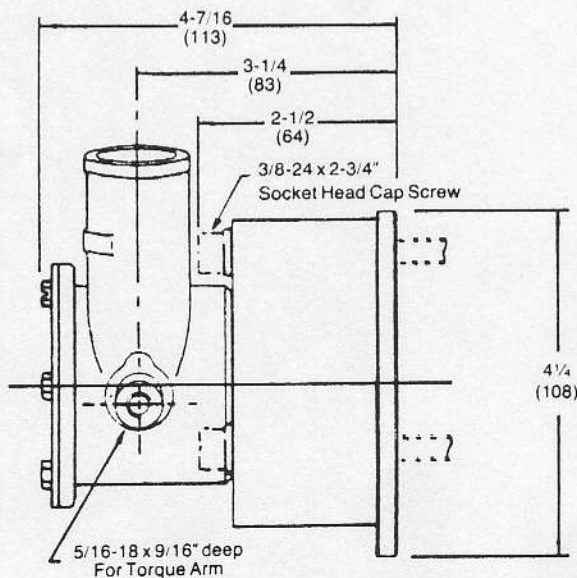
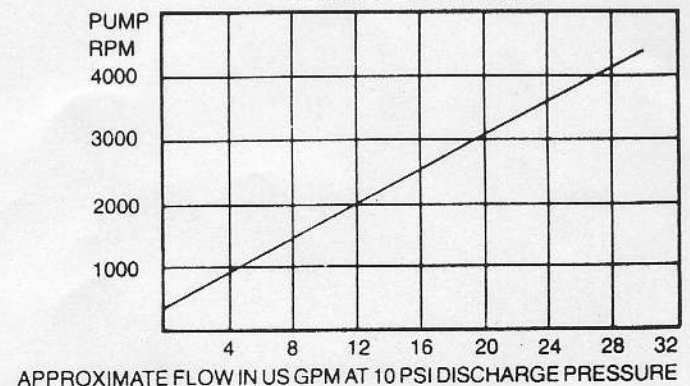
**PUMP FLOW CHART**

OPERATION

Do not run the pump over 5200 RPM. Be sure that the intake system is free from obstructions and the discharge system has less than 20 ft. of water head. The pump may be operated in either rotational direction. Inspect the pump periodically for leaks and vibration.

SERVICE INSTRUCTIONS

IMPELLER/GASKET REPLACEMENT

1. Remove the six end cover screws (Key 8). Remove end cover (Key 2) and end cover gasket (Key 4).
2. Remove the impeller (Key 5) by grasping the impeller hub with a pair of pliers. If the impeller has been damaged and sections are missing, be sure that all bits of the impeller are removed from the pump housing, ports, discharge line and heat exchangers.
3. Install the new impeller by rotating the impeller into the pump bore in the direction of operation (grease the pump bore to ease installation).
4. Replace the gasket and end cover tightening the end cover screws evenly.
5. Start engine and check for leaks and vibration.

CAM REPLACEMENT

1. Follow steps 1 and 2 of Impeller Replacement Instructions.
2. Remove the cam screw (Key 7) from the cam and pump body.
3. Remove cam (Key 3) and clean sealant from the cam and pump body.
4. Apply a thin coat of sealant to cam screw and top portion of the new cam and assemble to pump body.
5. Replace impeller, gasket and end cover to pump body.

MAJOR SERVICE

1. Remove the complete pump assembly from the engine.
2. Follow instructions 1 and 2 of Impeller Replacement Instructions.
3. Clean debris off the pump shaft (Key 1C).
4. The bearing housing (Key 1A) end of the pump has two access slots designed to allow removal of the snap ring (Key 9). Remove this snap ring completely from the snap ring groove.
5. The subassembly, consisting of shaft (Key 1C), bearing (Key 1B), and bearing housing (Key 1A), can now separate as one piece from the subassembly, consisting of the pump body (Key 1) and seal assembly (Key 6), by pulling the two assemblies apart by hand. The retaining ring will remain inside the bearing housing subassembly. If the assemblies will not separate by hand, lightly tap the pump body end of the pump shaft with a soft mallet (be sure not to damage the end of the pump shaft) until the pump body subassembly separates from the bearing housing subassembly.
6. Remove the seal from the pump body by pressing seal towards the end cover end of the pump body.
7. Clean all the shaft surfaces and inspect the surface behind the spline for corrosion and scratching. Replace the shaft, bearing, and bearing housing as one subassembly, if the shaft is damaged (shaft, bearing, retaining ring and bearing housing are sold and preassembled [22317-1000]).
8. Ensure that the seal bore is free of grease and debris. Insert the seal into the seal bore with lip pointing toward end cover side of body. Press it evenly into seal bore until it seats firmly against bottom of seal bore.

PARTS DIAGRAM

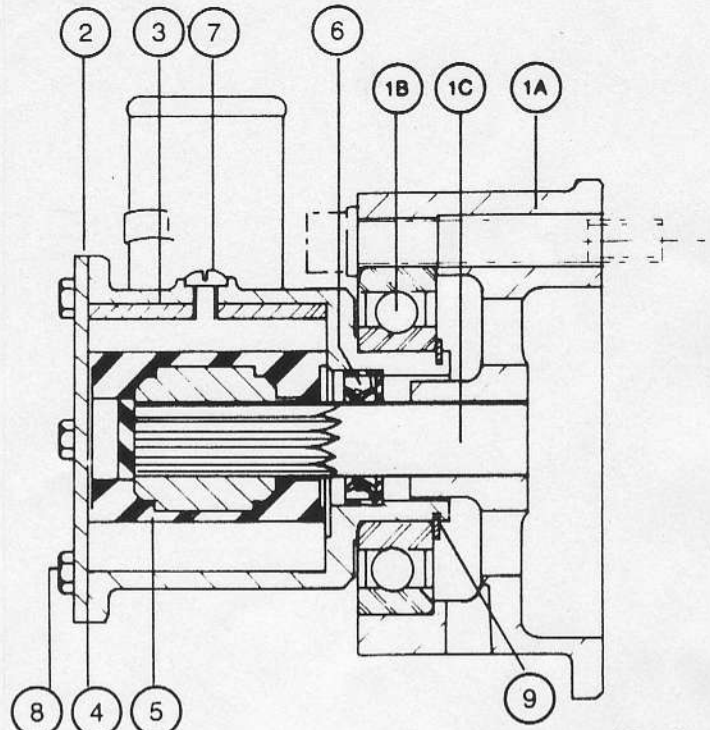

Socket Head Cap Screws for pump mounting not supplied.

PARTS LIST

KEY	DESCRIPTION	QTY. REQ.	PART #
1	Bearing Housing, Bearing, Retaining ring and shaft assembly.	1	22317-1000
2	End Cover	1	11830-1000
3	Cam (half)	1	22318-0000
4	Gasket	1	3298-0000
5	Impeller	1	22120-0001
6	Seal Assembly	1	92700-0060
7	Screw (Cam)	1	91004-0100
8	Screw (End Cover)	6	91002-0010
9	Retaining Ring	1	See Key 1

Big 1 92600-0330

9. Insert the shaft into the seal and slide the bearing housing/shaft assembly onto the pump body. Shaft, bearing, retaining ring and bearing housing assembly must slide onto the pump body until the retaining ring groove on the body is completely exposed through the back of the bearing housing.
10. Place the snap ring completely into its groove.
11. Replace the impeller, gasket and end-cover to the pump and assemble onto the engine. Connect hose.
12. Start engine and check for leaks and vibration.

THE PRODUCT DESCRIBED HEREIN IS SUBJECT TO THE JABSCO ONE YEAR LIMITED WARRANTY, WHICH IS AVAILABLE FOR YOUR INSPECTION UPON REQUEST.

Jabsco
ITT Fluid Technology Corporation
1485 Dale Way, P.O. Box 2158
Costa Mesa, CA 92628-2158
Telephone: (714) 545-8251