



Model 22060-5105

SANITARY PUMP

Standard Pressure Impeller ACME Ports

FEATURES

Body:	Type 316 Stainless Steel
Impeller:	Jabsco Sanitary Neoprene Compound
Seal:	Sanitary Mechanical
Bearings:	Ball/Roller Bearings
Shaft:	Type 316 Stainless Steel
Ports:	2-1/2" Acme Threads
Weight:	50 lb (23 kg) Approx.

APPLICATION

This product is specifically designed for farm pick-up milk tanker trucks. Jabsco pumps are also available as pedestal mounted or close-coupled units with capacities to 100 GPM for other sanitary applications. Contact factory for details.

OPERATING INSTRUCTIONS

1. **INSTALLATION** – Pump may be mounted in any position. The rotation of the pump shaft determines the location of the pump's intake and discharge ports. Refer to dimensional drawing. Pump is normally assembled at factory for clockwise rotation looking at end cover. If counterclockwise rotation is desired, follow steps 1 and 2 of disassembly and step 9 of assembly instructions to change direction of impeller blade deflection under cam.
2. **DRIVE** – Belt or direct with flexible coupling. Belt Drive: Overtight belt load will reduce pump bearing life. Direct Drive: Clearance should be left between drive shaft and pump shaft when installing coupling. Always mount and align pump and drive shaft before tightening the coupling set screw. If pulley or coupling must be pressed on shaft, remove end cover and impeller to support shaft from impeller end during press operation. Do not hammer pulley or coupling on shaft; this may damage bearing or seal. Capacitor start motor is required to overcome starting torque of impeller.



Model 22060-5105

3. **SPEEDS** – 100 RPM to the maximum shown in the performance curves. For longer pump life, operate at lowest possible speeds. Lower speeds are required for viscous liquids, consult the factory for proper speeds and horsepower requirements.
4. **SELF-PRIMING** – Primes at low or high speeds. For vertical dry suction lift of 10 feet, a minimum of 800 RPM is required. Pump will produce suction lift up to 22 feet when wet. **BE SURE SUCTION LINES ARE AIRTIGHT OR PUMP WILL NOT SELF-PRIME.**
5. **DISCHARGE** - When transferring liquids further than 25 feet, use 3" discharge line.
6. **RUNNING DRY** – Unit depends on liquid pumped for lubrication. **DO NOT RUN DRY** for more than 30 seconds. Lack of liquid will damage the impeller.
7. **PUMPAGE COMPATIBILITY** – When corrosive cleaning fluids are handled, pump life will be prolonged if pump is flushed with a neutralizing solution after each use or after each work day. A Tungsten Carbide Seal variation is available for pumping liquids that contain abrasives or are highly corrosive.
8. **PRESSURES** – Consult Performance Curves for maximum recommended pressures for pump in continuous operation. If pressures exceed those shown, consult the factory.
9. **TEMPERATURES** – The operating temperature limits of the pump: 45° to 150° F (7° to 65° C).

	WARNING Injury hazard. Exposed pulleys and belts can cause injury. Install shield around pulleys and belts. Stay clear while machinery is operating.
--	--

10. **CLEANING** – Before using pump, it should be disassembled and cleaned to remove any dust and dirt resulting from storage or shipping. Wash parts in standard cleaning solutions approved for handling stainless steel. Thoroughly rinse before reassembly. **DO NOT USE IODINE BASED SANITIZERS** as the iodine attacks the elastomer materials used in the impeller. All parts have been expertly machined and polished. **HANDLE WITH CARE. DO NOT DROP OR MISHANDLE.**

11. **IMPELLER TORQUE** – The torque required to initiate rotation of a new impeller in a dry pump body is:

- Forward = 10.2 pounds force – feet
- Reverse = 18.8 pounds force – feet

These values may vary slightly due to manufacturing tolerances. Consult factory for more information.

12. **SPARE PARTS** – To avoid costly shutdowns, keep a spare JABSCO impeller, seal and O-ring set on hand.

MANUAL BY-PASS CIP ENDCOVER FOR JABSCO PUMPS

Jabsco stainless-steel milk collection tanker pumps are easily cleaned in place at the same time that the tanker is cleaned. This can be achieved in 2 ways:

By running the pump to circulate the cleaning liquid through the pipe work and metering equipment; a separate land-based CIP pump may be used to provide the pressure to the tank spray balls. The pump and impeller can withstand hot water and proprietary chemicals for the duration of the cleaning cycle.

Alternatively, if the pump is fitted with the Jabsco Manual By-pass CIP Endcover Assembly the complete system can be cleaned with the milk collection pump static. This brings several advantages:

- **No Need To Run The Vehicle Engine:** The hydraulic system is not required during cleaning so no engine fumes are generated in the CIP bay, noise is much reduced and unnecessary fuel consumption is eliminated.
- **More Effective Cleaning:** Tests have shown that cleaning is more thorough with the Manual By-pass End Cover fitted.
- **Extended Pump Life:** During the cleaning cycle the pump is at greatest risk of running dry. If the cleaning fluid runs out e.g. during change-over from CIP fluid to rinse water, the pump impeller can be damaged if the pump is running. By cleaning the pump static, impeller life will be extended.

This end cover assembly fits in place of the standard pump end cover and contains a piston which moves back under the pressure from the separate CIP cleaning pump allowing cleaning fluid to by-pass the ends of the impeller.

CLEANING

Before starting the CIP pump, the center screw (24) of the manual by-pass assembly is loosened at least 10 turns counter-clockwise. This allows the piston (22) to travel back under the pressure of the CIP liquid. The system can then be cleaned using the regime established by the tanker operator; the pump does not need to be run or attended to in any way during cleaning. After cleaning, the center screw is tightened clockwise ready for normal pumping.

PIPE WORK

The pipe work can be arranged in two ways during cleaning:

1. **Parallel piping:** the flow from the CIP pump is split at a tee-piece so part of the flow is taken direct to the tanker spray balls while the rest flows through the pump and the metering equipment. See fig 1.
2. **Series piping:** all the CIP flow is directed through the pump and metering equipment and then on to spray balls. See fig 2.

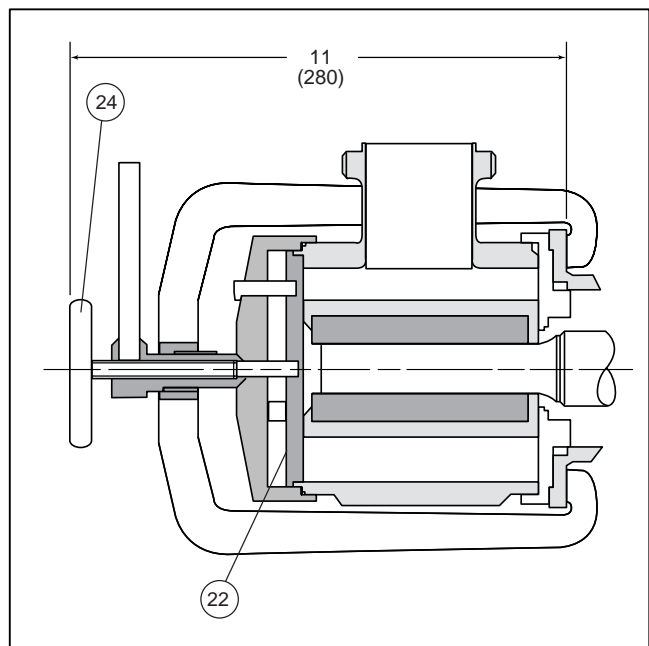
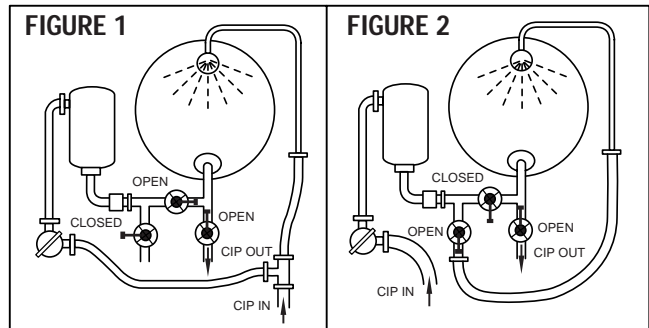

SERVICE INSTRUCTIONS

DISASSEMBLY

1. Remove end cover clamp. Remove end cover and O-ring.
2. Slide body, complete with impeller and wearplate, from shaft assembly. Remove impeller from body.
3. Remove mechanical seal from shaft. Use extreme care not to mar shaft surface. Remove seal seat and O-ring from recess in wearplate.
4. From the drive end of the bearing housing, pry out bearing seal by inserting a screwdriver blade between OD of the seal and housing. Remove retaining ring. Very carefully withdraw shaft and bearing assembly.
5. Remove inner bearing seal and retaining ring.
6. To remove bearings from shaft an arbor press is required. If an arbor press is not available then a bearing extractor may be used. Supporting inner race of bearing, apply a steady pressure on shaft until bearing slides free. Repeat this procedure to remove second bearing.

ASSEMBLY

1. To replace bearing on shaft. Support bearing on its inner race and locate shaft onto bearing. Apply a steady pressure to the shaft until bearing locates against shoulder on shaft. Repeat for second bearing.
2. Fit retaining ring and bearing seal into impeller end of bearing housing. Spring on bearing seal to face outwards.
3. Apply bearing grease around and between bearings, filling cavity between bearings two thirds full. Smear grease on shaft where bearing seal locates. Push shaft and bearing assembly into bearing housing.
4. Replace the two retaining rings and outer bearing seal, with spring facing outwards, on drive end of bearing housing.
5. Replace mechanical seal by sliding positioning washer onto shaft up to locating shoulder, then smear shaft with light lubricating oil. Push on seal gently until it engages with washer. Fit O-ring and seal seat into wearplate.
6. Insert impeller in pump body. Fit O-ring on each end of the pump body. Fit wearplate to body.
7. Slide wearplate and body assembly over shaft, positioning wearplate in housing.
8. Fit end cover and end cover clamp. Clamp should be hand tightened. Do not use wrench or hammer.
9. Changing Pump Rotation (looking at end cover):
Clockwise Rotation: Insert impeller into pump body with blades bending counterclockwise.
Counter-clockwise Rotation: Insert impeller into pump body with blades bending clockwise.

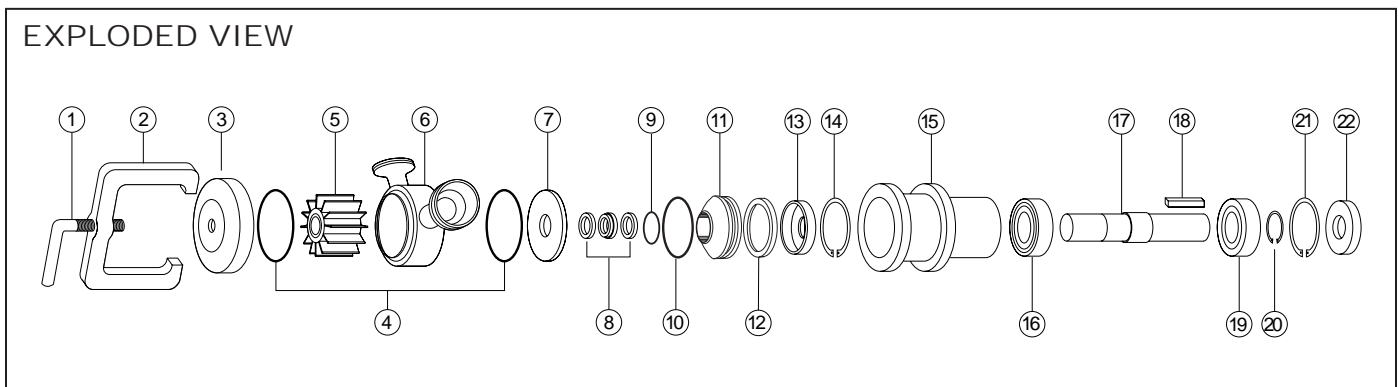

SPARE PARTS LIST

Key	Description	Qty.	Part Number	Key	Description	Qty.	Part Number
1	Clamp Screw	1	21908-0000	12	Lip Seal	1	X5280-011
2	Clamp Frame	1	21909-0000	13	Lip Seal Kit	1	92701-0880
3	End Cover	1	22007-0000	14	Retaining Ring (Hsg)	2	91701-4391
4	O-ring	2	92000-1213	15	Bearing Hsg	1	22064-0100
5	Impeller	1	8500-0005	16	Roller Bearing (front)	1	92601-0460
6	Body (Acme)	1	22004-5001	17	Shaft	1	28707-0000
7	Wearplate	1	21937-0000	18	Key	1	91402-0270
8	Seal Kit	1	22644-6000	19	Ball Bearing (rear)	1	92601-0450
9	V-Ring	1	X5280-015	20	Retaining ring (shaft)	1	91700-2870
10	O-ring	1	X4020-379A	*	By-Pass Endcover Kit	1	2870-0000
11	Seal Housing	1	23933-0000				

* Not Shown

DIMENSIONAL DRAWING
Inches (Millimeters)

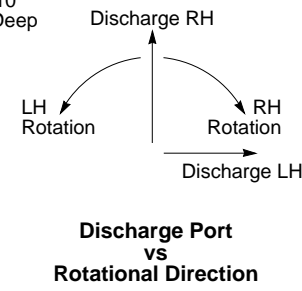
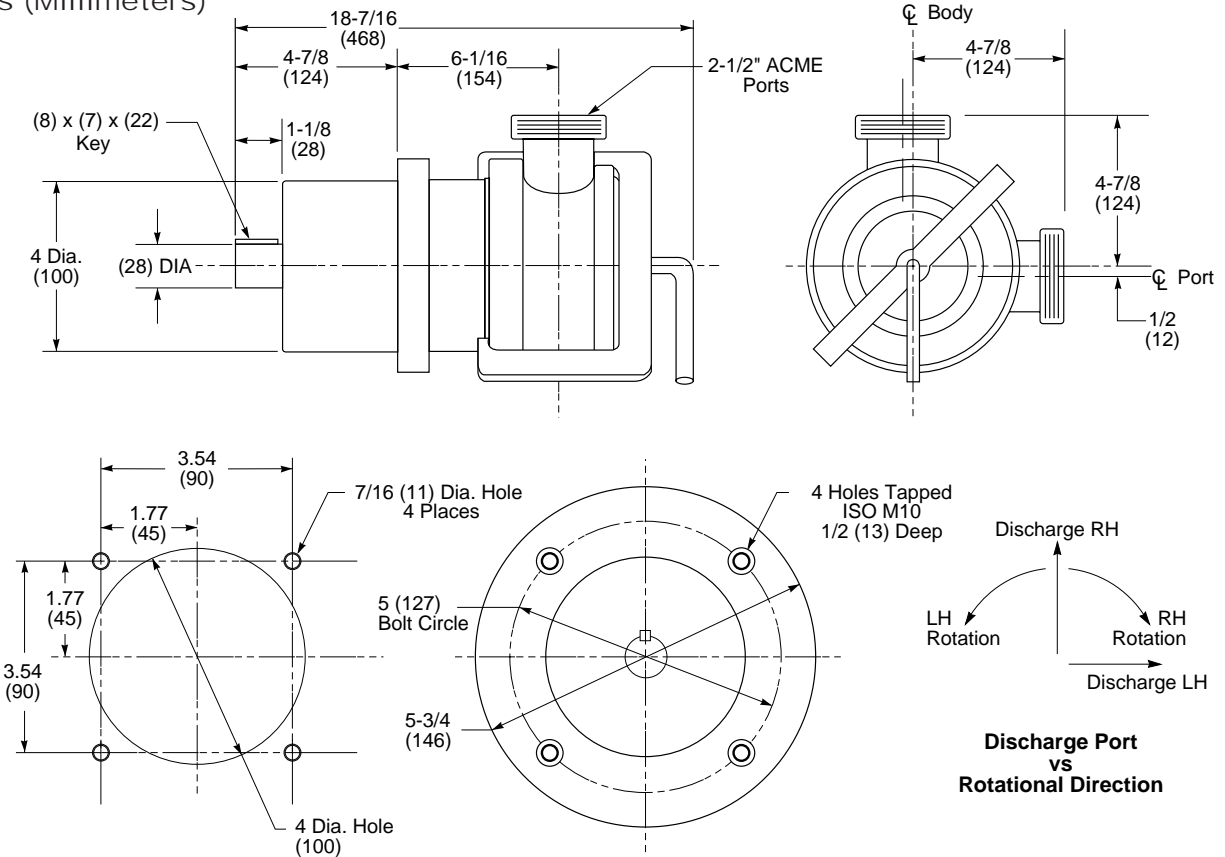

Mounting Hole Pattern

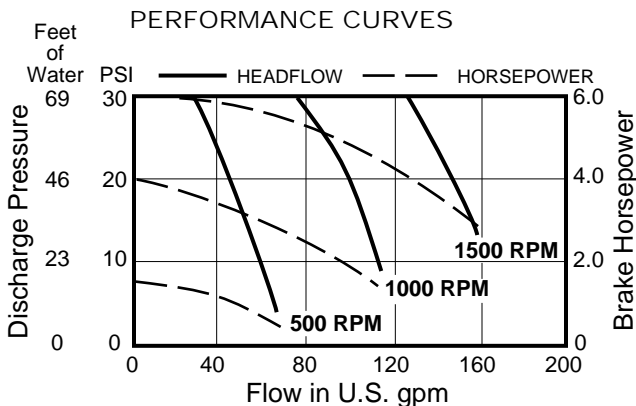

NOTE: Curves show approx. HEAD-FLOW for new pump with neoprene impeller pumping water.

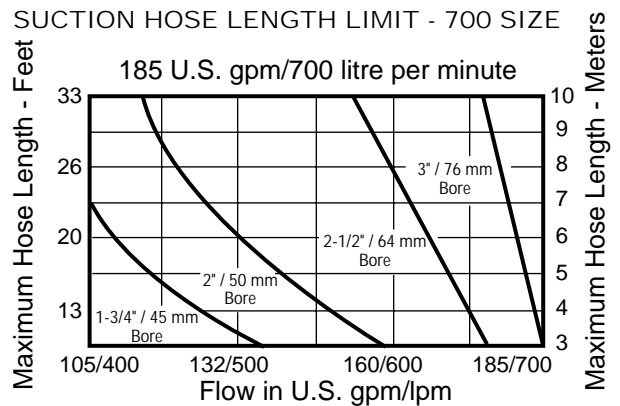

THESE GRAPHS ARE BASED ON: 2 inch (50 mm) diameter farm tank outlet. One elbow between suction hose and pump inlet. Farm tank milk level 0.5 m below pump level on vehicle.

Jabsco



THE PRODUCTS DESCRIBED HEREIN ARE SUBJECT TO THE JABSCO ONE YEAR LIMITED WARRANTY, WHICH IS AVAILABLE FOR YOUR INSPECTION UPON REQUEST.

U.S.A.
Jabsco
20 Icon
Foothill Ranch, CA 92610-3000
Tel: 949.609.5106
Fax: 949.859.5129

UNITED KINGDOM
Jabsco
Bingley Road, Hoddesdon
Hertfordshire EN11 0BU
Tel: +44 (0) 1992 450145
Fax: +44 (0) 1992 467132

CANADA
Fluid Products Canada
55 Royal Road
Guelph, Ontario N1H 1T1
Tel: (519) 821.1900
Fax: (519) 821.2569

JAPAN
NHK Jabsco Company Ltd.
3-21-10, Shin-Yokohama
Kohoku-Ku, Yokohama, 222
Tel: 045.475.8906
Fax: 045.475.8908

GERMANY
Jabsco GmbH
Oststrasse 28
22840 Norderstedt
Tel: +49-40-53 43 73 -0
Fax: +49-40-53 53 73 -11