

SELF-PRIMING PUMPS MARINE ENGINE COOLING

FEATURES

Body:	Bronze
Bearing Housing:	Bronze
Impeller:	Jabco Neoprene Compound
Shaft:	Stainless Steel
Shaft Seal:	Carbon-Ceramic Face Type
Bearings:	Sealed Ball Bearing
Ports:	1" ID Hose
Shipping Weight:	5 lb

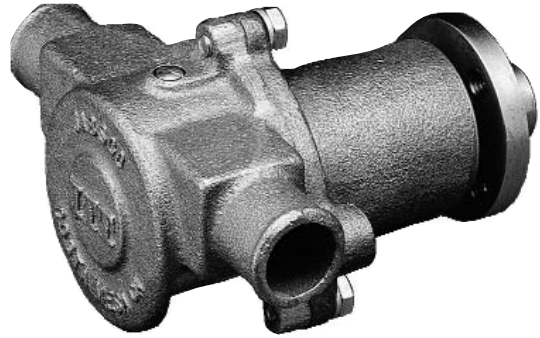

Model 18830-Series

APPLICATION

Marine engine cooling.



WARNING Injury hazard. Exposed pulleys and belts can cause injury. Install shield around pulleys and belts. Stay clear while machinery is operating.

PERFORMANCE

PUMP FLOW CHART

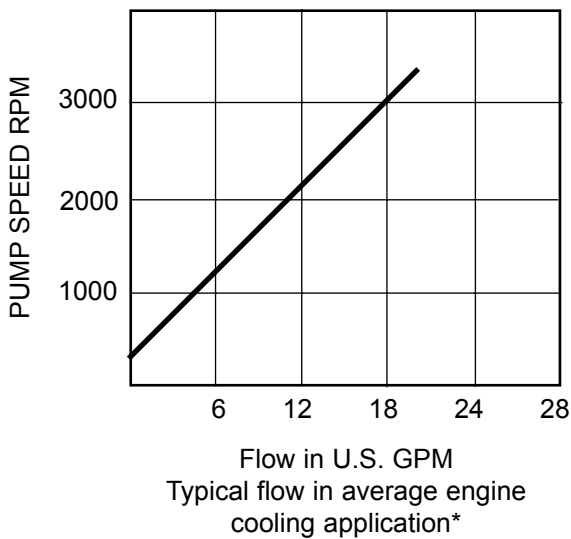

*Average engine cooling applications have discharge pressures of 0-15 psi and inlet vacuums of 3-5 inches of mercury.

VARIATIONS

Model No. 18830-0000
Supplied with pulley mounting adaptor

Replaces Sherwood G-30-2 for Chris Craft engines (305, 327 and 350 C.I.)

Glastron (some models)

Pleasurecraft (some models)

Volvo (some early models)

Model No. 18830-0010
Supplied with 6-1/2" "A" belt pulley

Model No. 18830-1020
Supplied with 3/16" key only
and high pressure impeller ***

Commander Marine 302, 351 C.I.

Glastron 302, 351 C.I. Class 165, 190, 200 & 225

***For use where system pressures range between 15-25 psi total developed head.

SERVICE INSTRUCTIONS

Disassembly

- 1) Remove the three impeller housing screws (key 13).
 - 2) Slide impeller housing (key 2) off the bearing housing (key 3) and shaft (key 4) assembly.
 - 3) Grasping hub of impeller (key 1) with pliers, remove it from impeller housing.
 - 4) Remove cam screw (key 12) from the impeller housing. Slide the cam (key 6) out of the impeller housing.
 - 5) Remove the O-ring (key 7) from the impeller housing groove.
TO REMOVE SEAL ASSEMBLY, THE SHAFT AND BEARING ASSEMBLY MUST BE REMOVED FROM THE BEARING HOUSING (KEY 3).
- 18830-0000 with press fit pulley adaptor
- 6) Remove pulley (not included) from the pulley adaptor (key 5).
 - 7) Solidly support the pulley adaptor and bearing housing. Drive roll pin (key 11) out of the pulley adaptor and shaft subassembly.
 - 8) Using a wheel puller tool, pull the pulley adaptor (key 5) off the pump shaft (key 4).
 - 18830-0010 with slip fit 61/2" pulley
 - 6) Solidly support the pulley and bearing housing. Drive roll pin (key 11) out of the pulley and shaft subassembly.
 - 7) Loosen pulley set screw.
 - 8) Remove pulley (key 5) and key (key 16) from shaft.
 - 18830-1020 is not supplied with a pulley or pulley adaptor; therefore, drive mechanism removal should be determined by its type of fit to shaft.
 - 9) Remove the retaining ring (key 10) out of the bearing housing (key 3).
 - 10) Lightly tap the spline end of the shaft. Shaft and ball bearings (key 9) should slide out of the bearing housing. **BE CAREFUL NOT TO DAMAGE SPLINE END OF SHAFT.**
 - 11) Ceramic portion of the seal (key 8) assembly normally will stay on the shaft. **THE BRASS/CARBON PORTION OF THE SEAL SHOULD HAVE REMAINED IN THE BEARING HOUSING.** Lightly press this portion from the pulley end of the bearing housing toward the impeller end of the bearing housing.
 - 12) Press ball bearings (key 9) off the shaft by supporting each bearing on its inner race to prevent damage.

Assembly

- 1) Clean and inspect all components for wear or damage. Replace all components where needed.
- 2) Lightly lubricate pump shaft (key 4) and press bearings (key 9) onto shaft by applying force to inner race of the bearing. **DO NOT APPLY FORCE TO OUTER RACE OF BEARING.**
- 3) Slide ceramic (white) portion of seal (key 8) onto spline end of shaft with large white face toward spline end.
- 4) Lightly press the brass/carbon portion of the seal into the bearing housing (key 3); be careful not to damage the carbon face of the seal. Brass face should face toward impeller end of pump and be pressed flush with bottom of counter-bore.
- 5) Lightly press shaft, bearing and shaft seal (ceramic portion) subassembly into bearing housing; be careful not to damage shaft end or seal components during this assembly.
- 6) Replace bearing retaining ring (key 10) into bearing housing.
 - 18830-0000 with press fit pulley adaptor
- 7) Support spline end of shaft and bearing housing. Press pulley adaptor (key 5) onto the shaft. Make sure that roll pin hole in shaft lines up with hole in pulley adaptor.
- 8) Drive roll pin (key 11) into pulley adaptor and shaft.
 - 18830-0010 with 6-1/2" slip fit pulley
- 7) Slide pulley (key 5) onto shaft. Make sure that roll pin hole in shaft lines up with hole in pulley.**
- 8) Drive roll pin (key 11) into pulley and shaft and tighten set screw.
 - 18830-1020 is not supplied with a pulley or pulley adaptor. If the driving mechanism is a press fit, the spline end of the shaft must be supported when pressing the fitting onto the shaft.
- 9) Apply a thin coat of sealant to convex side of cam (key 6) and threads of cam screw (key 12), fasten cam to impeller housing.
- 10) Slide impeller (key 1) onto shaft spline and place spline seal in impeller bore.
- 11) Place O-ring (key 7) into groove in impeller housing and cam subassembly. Lubricate impeller bore. With a twisting motion, slide the impeller housing over the impeller. Be sure the direction the impeller blades are bent matches the direction of normal engine and pump rotation.
- 12) Fasten impeller housing to bearing housing with the three machine screws and washers (key 13 and 14).
- 13) Test pump following instructions under Installation and Operation section above.

*If the roll pin hole cannot be aligned through pulley and shaft, drill a new 1/8" hole for roll pin at an angle as close to 90° from original hole as possible. Center punch pulley hub or file a flat spot on hub to ease start of drilling procedure. Position new hole so it does not pass through old hole.

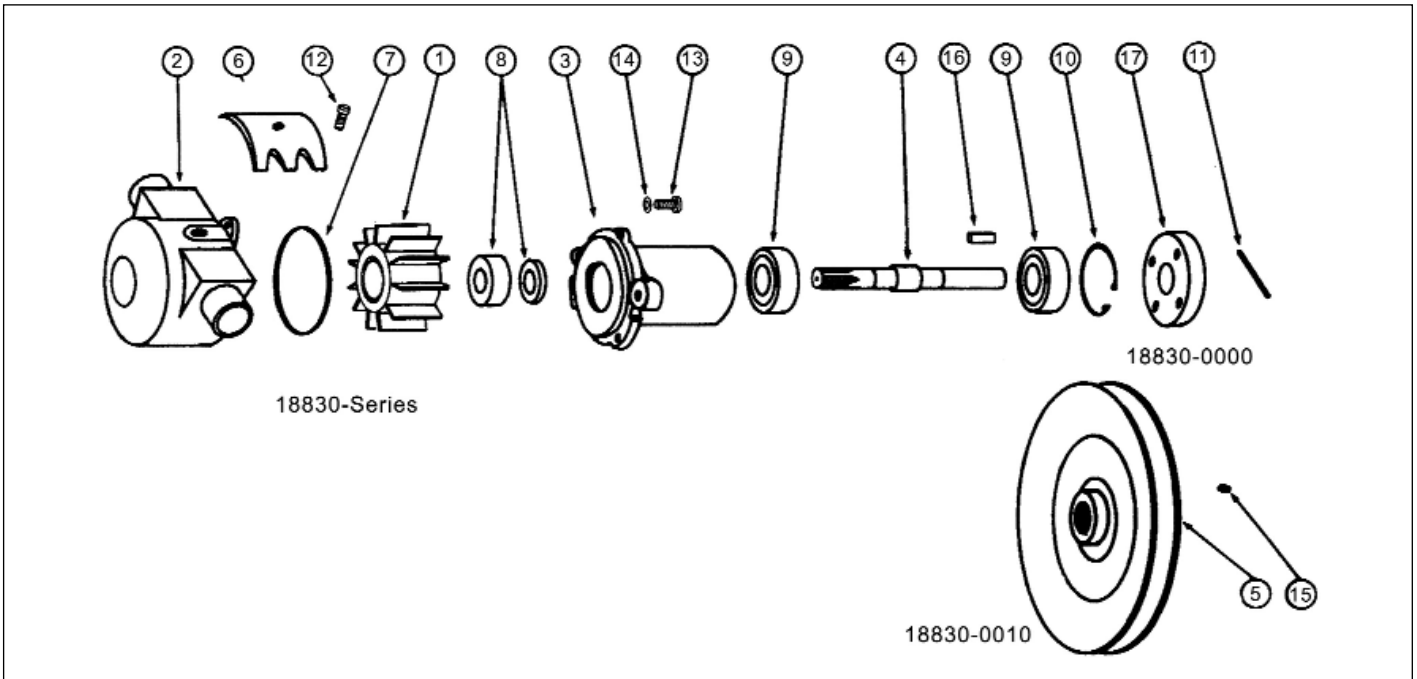

INSTALLATION AND OPERATION

The pump may be mounted in any position. The direction of rotation of the pump determines the location of the intake and discharge ports (refer to dimensional drawings). Before installing, rotate the pump shaft in the direction of normal operating rotation. The mounting bracket used to support the pump must be designed to enable adjustment of the pump position for proper drive belt tension.

Attach the pump to the mounting bracket using two 5/16" x 18 hex head screws. The pump mounting holes are tapped to this thread size and are 1/2" deep. Attach the drive pulley to the shaft hub on Model 18830-0000 using four 5/16" x 18 hex screws. If drive pulley must be pressed on shaft (model 18830-1020), it is essential to remove impeller housing and impeller to support spline end of shaft during pressing operation. Put pulley drive belt over both the drive pulley and the pump pulley. An "A" section pulley belt should be sufficient to drive the 18830-Series pump.

Position the pump to allow 1/2" deflection of the drive belt midway between the engine and pump pulleys. Secure the pump mounting brackets. Attach 1" ID hose to the ports and clamp using two stainless steel band clamps per port (be sure to attach the water intake line to the proper pump port).

Be sure that all suction lines are air tight so that the pump will self prime. Start the engine and run at low speed. This pump depends on the water for lubrication. **DO NOT RUN DRY** for more than 30 seconds. Lack of water will damage the impeller. This pump is designed for liquids between 45° and 180° F. Pumping colder water will shorten impeller life.

Cooling systems should be designed so the cooling pump operates at no more than 15 psi output pressure and 5 inches of mercury inlet vacuum.

WINTERIZING

Drain the pump by loosening the impeller housing bolts and loosening - the housing. Flush cooling system with an ethylene glycol base antifreeze. Do not use a petroleum based rust inhibitor in the pump.

SPARE PARTS LISTING

KEY	DESCRIPTION	PART NUMBER	QTY.
1*	Impeller	1210-0001	1
	Impeller, 18830-1020 only	3085-0001	1
2	Impeller Housing	18834-1000	1
3	Bearing Housing	18833-1000	1
4	Shaft	18836-1000	1
5	Pulley	18753-0006	1
6	Cam	490-0001	1
7*	O-Ring	18753-0005	1
8*	Seal	96080-0080	1
9	Ball Bearing	92600-0120	2
10†	Retaining Ring	See Hrdw. Kit	1
11†	Roll Pin	See Hrdw. Kit	1
12	Cam Screw	91003-0010	1
13††	Screw	See Screw Kit	3
14††	Lock Washer	See Screw Kit	3
15†	Set Screw	See Hrdw. Kit	1
16†	Key	See Hrdw. Kit	1
17	Pulley Adaptor	18835-1000	1
	Service Kit	90180-0001	
	Hardware Kit	18753-0010	
	Screw Kit	18753-0001	

* Included in Service Kit

† Included in Hardware Kit

†† Included in Screw Kit (3 each)

DIMENSIONAL DRAWING INCHES (MILLETRES)

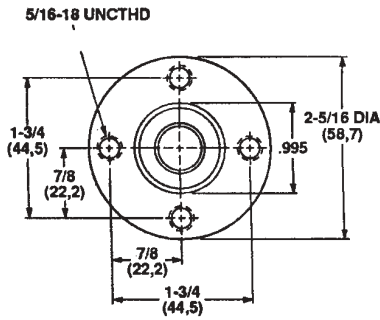

**PULLEY MOUNTING PLATE
USED ON MODEL 18830-0000**

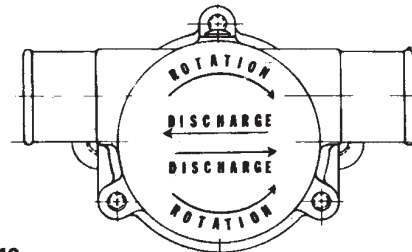
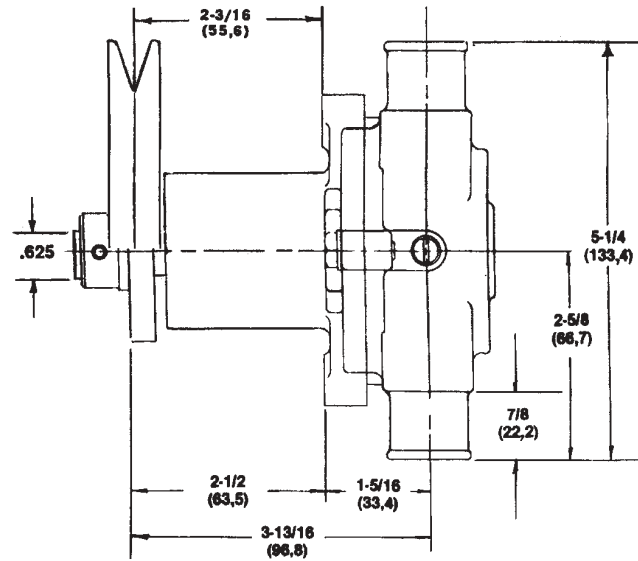
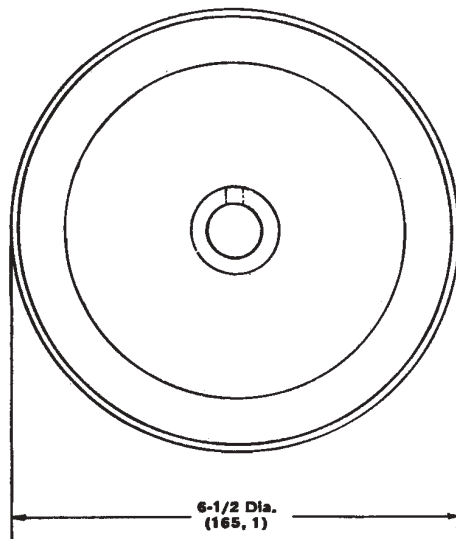

**PULLEY (A BELT)
USED ON MODEL 18830-0010**

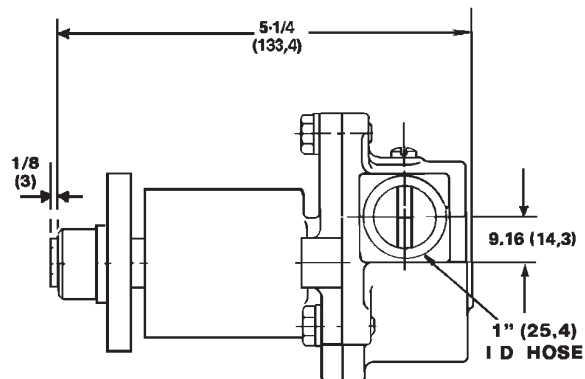
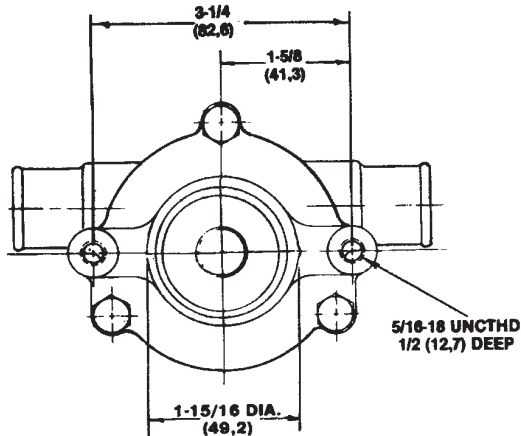

Jabsco



ITT Industries

Jabsco, 20 Icon, Foothill Ranch, CA 92610
Tel : +1 949 859 4945 Fax : +1 949 859 1153

Jabsco, Bingley Road, Hoddesdon, Hertfordshire, EN11 0BU
Tel : +44 (0) 1992 450 145 Fax : +44 (0) 1992 467 132

Fluid Products Canada, 55 Royal Road, Guelph, Ontario N1H 1T1
Tel : +1 519 821 1900 Fax : +1 519 821 5316

NHK Jabsco Co Ltd, 3-21-10, Shin - Yokohama, Kohoku-ku, Yokohama 222
Tel : +81 (0) 45 475 8906 Fax : +81 (0) 45 475 8908

Jabsco GmbH, Oststraße 28, 22844 Norderstedt
Tel : +49 (0) 40 53 53 73 0 Fax : +49 (0) 40 53 53 73 11

USA

UK

CANADA

JAPAN

GERMANY

Warranty: All products of the company are sold and all services of the company are offered subject to the company's warranty and terms and conditions of sale, copies of which will be furnished upon request.
The information provided herein is for guidance only, it does not constitute a guarantee of the performance or specification of any individual product or component.
©Copyright 2003 ITT Industries

43000-0411 Rev: 01/03