



SELF-PRIMING PUMPS

FEATURES

- Body: Bronze
- Impeller: Neoprene, Nitrile
- Shaft Seal: Lip Type
- Ports: 3/8" NPT Female
Two 3/4" Male Garden
Hose Adapters Included
- Motor: 1/6hp - 115V AC, 60 Hz ODP Motor
1/4hp - 115V AC, 60 Hz TENV Motor
- Protection: Thermal Overload
- Shaft: Stainless Steel
- Cord: 8' Cord with 3 Prong Grounded Plug
- Weight: 12 lbs (5.4 kg)



Model 18655 Series

⚠ WARNING	Explosion hazard. Do not use where flammable vapors are present. Do not pump gasoline, solvents, thinners or other flammable liquids. To do so can cause an explosion resulting in injury or death.
------------------	--

VARIATIONS AVAILABLE

MODEL NO.	DESCRIPTION
18655-0001	Open Drip Proof Motor, Neoprene Impeller
18655-0003	Open Drip Proof Motor, Nitrile Impeller
18655-0271	Totally Enclosed Motor, Neoprene Impeller

APPLICATIONS

INDUSTRIAL

Circulating, transferring, velocity-mixing, pumping machine tool coolants, sump drainage, soap, ink, dyes, alcohol, glycerine, brine and heliarc welding equipment cooling.

FARMING

Livestock watering, pumping water from shallow wells and cisterns.

MARINE

Washdown and utility dock side pumping.

PLUMBING & HOME EMERGENCY USE

Pumping out flooded basements, cesspools, sumps, water heaters and water closets, drains and sinks, draining fishponds and small pools.

PUBLIC UTILITIES AND MUNICIPALITIES

Dewatering and draining meter boxes and excavations, dust control and sampling.

OPERATING INSTRUCTIONS

1. **INSTALLATION:** Pump may be mounted in any position. Inlet port is on the right and discharge port on the left when facing pump.
2. **SELF-PRIMING:** Dry suction lift is 6 feet. Dry suction lift with Neoprene impeller. Pump will produce suction lift up to 20 feet when wetted. **SUCTION LINES MUST BE AIRTIGHT OR PUMP WILL NOT PRIME.**
3. **DISCHARGE LINE:** When transferring liquids further than 25 feet, discharge line size should be increased to next available pipe size.
4. **RUNNING DRY: DO NOT RUN DRY.** Impeller depends on liquid pumped for lubrication. Dry running will damage the impeller and void warranty.
5. **NOTICE:** Consult Jabsco Chemical Resistance Table for appropriate body and impeller materials. Pump life is prolonged if pump is flushed with water after each use.
6. **LIQUID TEMPERATURE RANGE:**
 - Neoprene: 45° to 180° F (7° to 82° C)
 - Nitrile: 50° to 180° F (10° to 82° C)
7. **FREEZING WEATHER:** Loosen end cover screws to drain pump. Use glycol and alcohol based anti-freeze compounds. **DO NOT USE PETROLEUM BASED ANTI-FREEZE COMPOUNDS OR RUST INHIBITORS.**

SERVICE INSTRUCTIONS

⚠ CAUTION Corrosive, caustic, or toxic fluids should be drained and flushed completely prior to service. Failure to do so can cause injury. Do Not Service With Power Connected.

DISASSEMBLY

Refer to Exploded View on the following page.

1. Remove end cover screws (1) end cover (2), and O-ring (3).
2. Remove impeller (4).
3. Loosen and remove the two slotted hex screws (7) that attach pump body (6) to motor (8).
4. Disengage the shaft seal (5) from the seal bore using a 1/2" diameter dowel. Push the shaft seal from the motor-side of the pump body.
5. Do not tamper with or disassemble the motor.

ASSEMBLY

1. Lubricate seal (5) with water. Position seal in bore with hollowed-out side of lip seal pointing toward the impeller bore. Using a 1/2" dowel, push seal into bore until it contacts the bottom.
2. Lubricate motor shaft and install body (6) on motor.
3. Lubricate impeller bore. Align impeller (4) and motor shaft flats. Install impeller with a clockwise motion.
4. Install O-ring (3), end cover (2) and screws (1).

EXPLODED VIEW

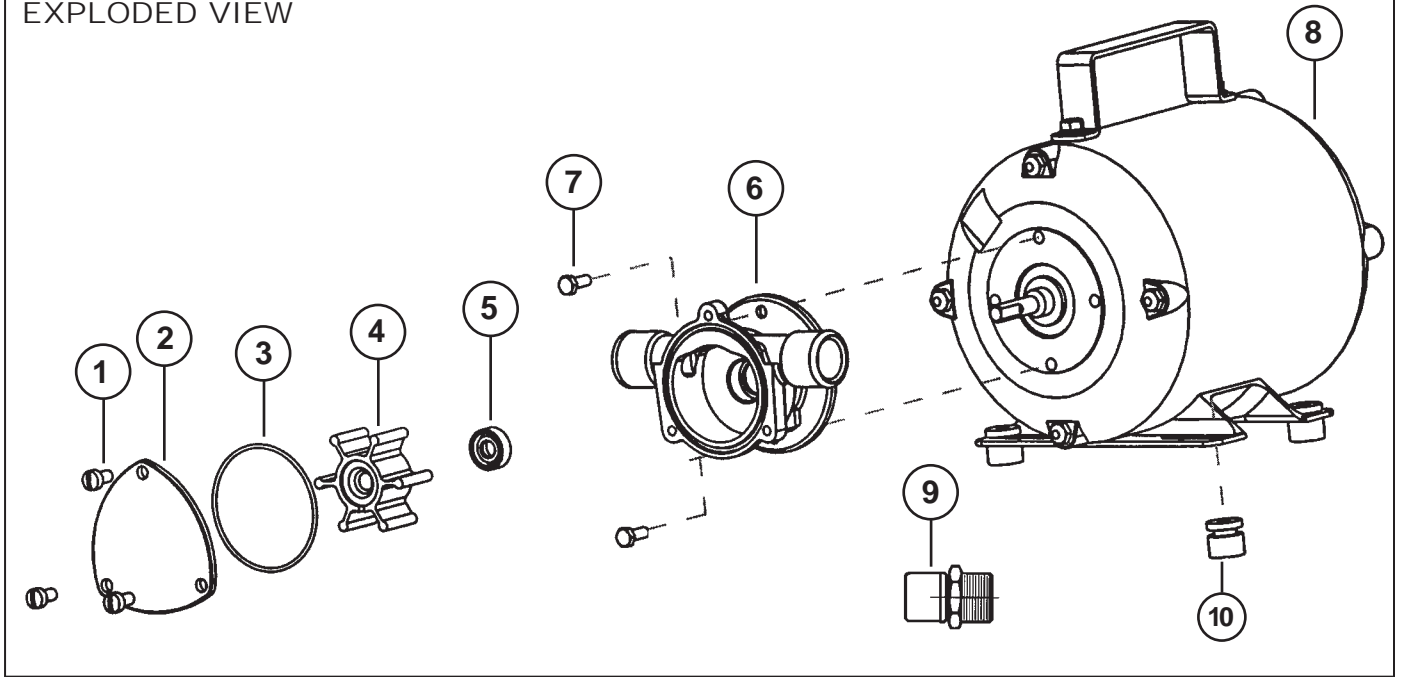

PARTS LIST

Key	Description	Kit No.
1	End Cover Screw Kit	18753-0102
2	End Cover	18647-0000
3	O-Ring*	18753-0660
4	Impeller*: Neoprene	9200-0021
	Nitrile	9200-0023
5	Lip Seal*: Nitrile	18753-0384
6	Body	18646-0000
7	Screws Pump-to-Motor	98019-0020
8	Motor: 18655-0001	18740-0000
	18655-0003	18740-0000
	18655-00271	18742-0000
9	3/4" Male Garden Hose Adapter	93009-0238
10	Rubber Bumper Kit	92900-0020
	Service Kits For:	
	18655-0001	90061-0030
	18655-0271	90061-0030
	18655-0003	90061-0035

* Parts supplied in Service Kit

DIMENSIONAL DRAWING

Inches (Millimetres)

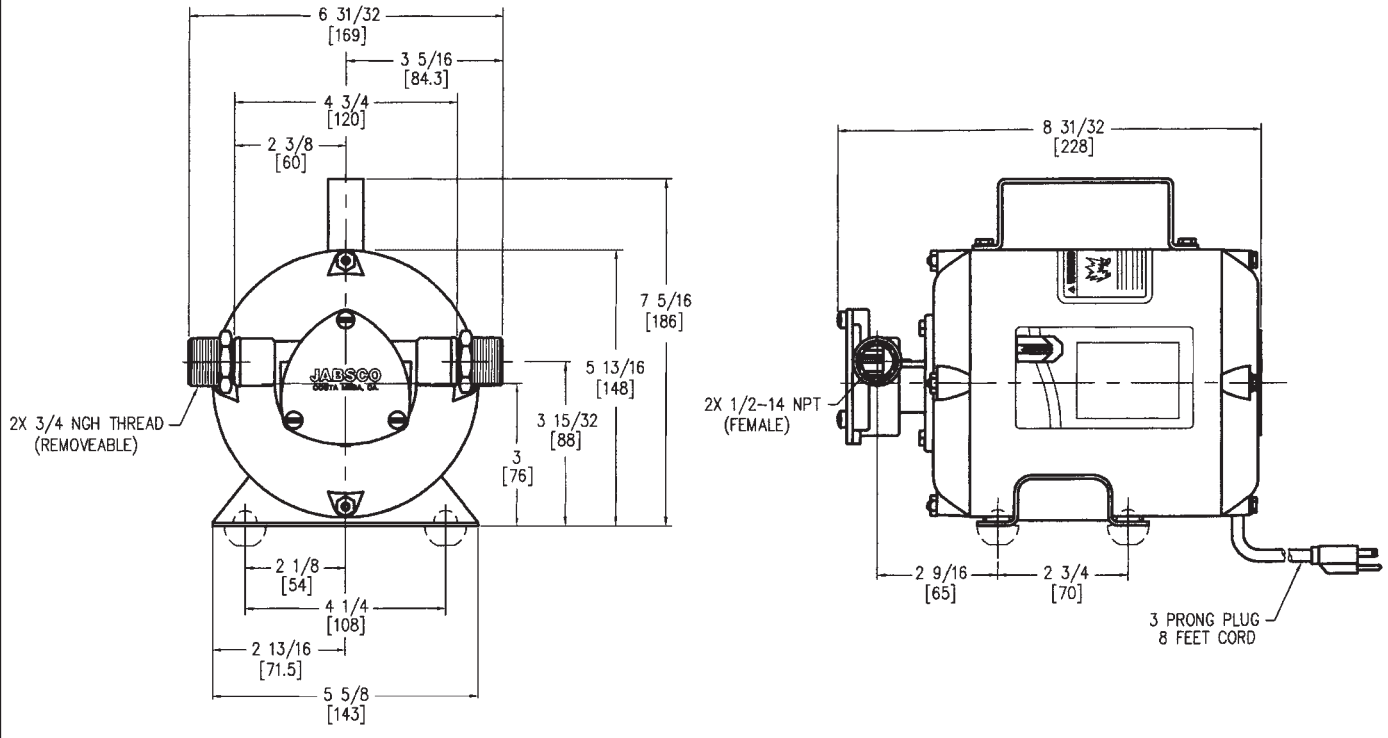

HEAD CAPACITY TABLE

TOTAL HEAD				CAPACITY	
Feet	PSI	Meters	Kg/cm ²	18655-0XXX	
				Gpm	Lpm
10	4.3	3.1	0.31	2.8	10.6
20	8.7	6.1	0.61	2.6	9.9
30	13.0	9.1	0.91	2.5	9.3
40	17.3	12.2	1.22	2.3	8.5
50	21.7	15.2	1.52	1.9	7.1

Typical performance in US gallons per minute and liters per minute pumping water.

Jabsco



ITT Industries

Engineered for life

THE PRODUCTS DESCRIBED HEREIN ARE SUBJECT TO THE JABSCO ONE YEAR LIMITED WARRANTY, WHICH IS AVAILABLE FOR YOUR INSPECTION UPON REQUEST.

U.S.A.
Jabsco
Cape Ann Industrial Park
Gloucester, MA 01930
Tel: 978.281.0440
Fax: 978.283.2619

UNITED KINGDOM
Jabsco
Bingley Road, Hoddesdon
Hertfordshire EN11 0BU
Tel: +44 (0) 1992 450145
Fax: +44 (0) 1992 467132

CANADA
Fluid Products Canada
55 Royal Road
Guelph, Ontario N1H 1T1
Tel: 519 821.1900
Fax: 519 821.2569

JAPAN
NHK Jabsco Company Ltd.
3-21-10, Shin-Yokohama
Kohoku-Ku, Yokohama, 222
Tel: 045.475.8906
Fax: 045.475.8908

GERMANY
Jabsco GmbH
Oststrasse 28
22840 Norderstedt
Tel: +49-40-53 53 73 -0
Fax: +49-40-53 53 73 -11