

## SEAL-LESS MAGNETIC DRIVE CENTRIFUGAL PUMPS

### FEATURES

- Pump Material:** Glass-filled epoxy plastic suitable for temperatures to 200°F (93°C)
- Impeller Design:** Enclosed 4.50" Dia.  
4.35" Dia.  
4.00" Dia.  
3.50" Dia.
- Magnetic Drive:** Impeller magnets enclosed in a molded epoxy cup. Minimum decoupling torque is 40 in. - lbs.
- Ports:** Suction 1-1/2" NPT Internal  
Discharge 1" NPT Internal.
- Bearing Housing:** Cast iron, protective enamel painted
- Shaft:** Carbon steel
- Bearings:** Ball bearings
- Weight:** 14-1/2 lbs (6,6 kgs)

### STANDARD MODELS

IMPELLER SIZE	MODEL NUMBER
4.50" Dia.	18640-0003
4.35" Dia.	18640-0000
4.00" Dia.	18640-0001
3.50" Dia.	18640-0002

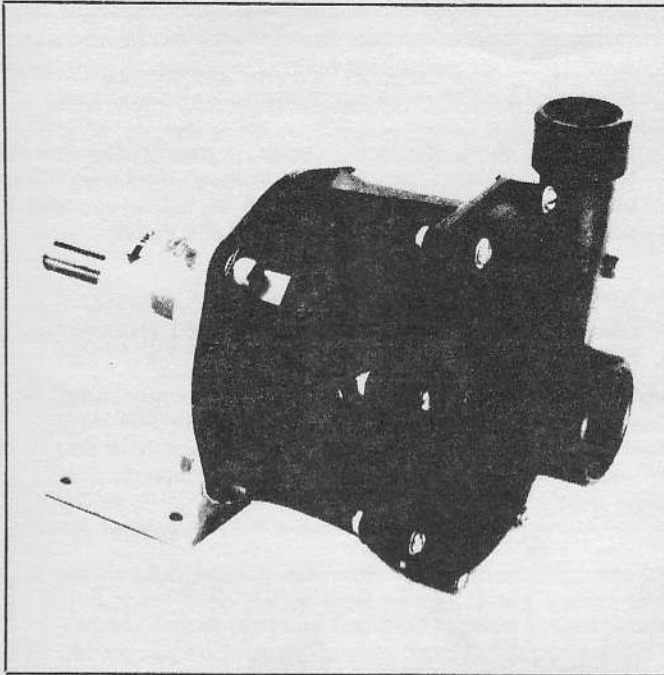

### APPLICATIONS

The seal-less magnetic drive pedestal mounted centrifugal pump may be belt driven or direct coupled to an electric motor, air motor, hydraulic or variable speed drives provided by the customer. Thus, a substantial variety of driver characteristics are available to accommodate a wide range of liquids whose specific gravity and viscosity differ from water.

The seal-less magnetic drive centrifugal pumps are designed to handle corrosive liquids without concern for selection of exotic mechanical shaft seal materials or leakage of expensive or dangerous fluids between shaft and housing.

Highly corrosive chemicals or caustic solutions compatible with glass-filled epoxy plastic may be transferred or circulated. All

parts in contact with fluid are glass-filled epoxy plastic, Ryton\*, ceramic, or graphite filled Teflon\*. A Viton\* O-ring gasket is also used.

For a comprehensive list of chemicals and their compatibility with epoxy plastic, consult the Jabsco Chemical Resistance Table (which is available upon request from ITT Jabsco) or contact the factory.

Typical applications include transfer, circulation or filtration of photo chemicals, etching solutions, plating baths, laboratory systems, processing transfer and application of agricultural chemicals (not wettable powder solutions), fume scrubbing, circulation and precious metal recovery processes.

### INSTALLATION

**LOCATION** — Pump should be mounted with shaft horizontal. Volute may be removed and rotated to any of eight different port positions to simplify piping. It is prudent, however, to install body and piping to eliminate possibility of air pockets in either the suction or discharge passages.

If the pump is to be mounted above the liquid level, provision must be made to assure that the suction line and pump cavity are flooded before starting the pump. **THIS PUMP WILL NOT SELF PRIME!**

To prevent cavitation and obtain maximum service life, it is important that suction line is free of restrictions and sharp bends. Factory application engineering assistance is available.

**PLUMBING** — All piping to the pump must be supported independent of the pump. Keep suction and discharge lines as free of elbows and bends as possible. To assure optimum performance, line to suction port should be the same size as suction port and be straight for a minimum length of 12" without elbows or reducers.

**NOTICE:** To prevent cracking port, extreme care must be exercised when metal port fittings are used. Plastic port fittings are recommended. Use Teflon tape or Locktite\* PST pipe sealant

to seal threads. Do not overtighten. Damage to pump may result.

Suction line must be airtight to maintain prime. A flap type foot valve at the suction intake or a check valve in the discharge line may be installed to retain liquid in a system during shutdown. Auxiliary priming and drain lines may be installed by drilling and tapping the surfaces provided on the volute face (see dimensional drawing).

**WARNING: EXCESSIVE PRESSURE MAY CAUSE PUMP HOUSING FAILURE. SEVERE PERSONAL INJURY OR DEATH MAY OCCUR. DO NOT ALLOW OUTLET PRESSURES TO EXCEED 40 psi (2,8 kg/cm<sup>2</sup>).**

**MOTOR SELECTION** — Refer to performance curves and notes on specific gravity or viscosity to calculate proper horsepower requirement for drive motor. The ball bearing equipped, pedestal mounted magnetic drive centrifugal pump permits direct coupling or belt drive to a motor of your choice, which may be obtained from local source, and mounted on a simple channel base to drive the pump in a manner most suited for your requirements.

## INSTALLATION (cont'd)

**BELT DRIVE** — Proper belt tension will insure optimum pump performance, belt and bearing life. Consult belt manufacturer for proper tensioning and alignment of belts.

**DIRECT DRIVE**— A flexible coupling is recommended. Be sure there is clearance between the motor shaft and pump shaft when installing coupling. Mount and align pump and motor shaft before tightening coupling set screws.

**MAXIMUM OPERATING SPEEDS** — Do not operate at speeds above 3800 RPM without consulting factory. Ball bearing life will be reduced if operated at higher speeds. **DO NOT OVER PRESSURE PUMP.**

**HORSEPOWER REQUIRED** — Depends on pump speed and specific gravity of fluid. Refer to performance curves and notes on specific gravity and viscosity to calculate proper horsepower requirement for application. Factory application engineering assistance is available.

**OPERATION** — Pump must be primed to begin pumping operation. Do not operate pump dry. Dry running or starved suction will reduce the service life of the pump.

If pumping action ceases during normal operation and the motor continues to run, magnetic drive may have uncoupled. Disconnect power to the motor, let pump motor come to complete stop, then resume operation. This allows magnetic drive to recouple.

Recurring uncoupling indicates excessive horsepower requirements or friction contact between internal components. Inspect pump for particulate build up between impeller/magnet assembly I.D., Teflon bearing and magnet housing boss.

Change in liquid viscosity or specific gravity may also affect power requirement: Restrict flow through discharge line until pump operates without uncoupling or motor overload kick out occurring. **DO NOT OVER PRESSURE PUMP.**

In applications where Ryton is not compatible with the chemicals being pumped, a kit containing a stainless steel cap bolt and two carbon bushings is offered.

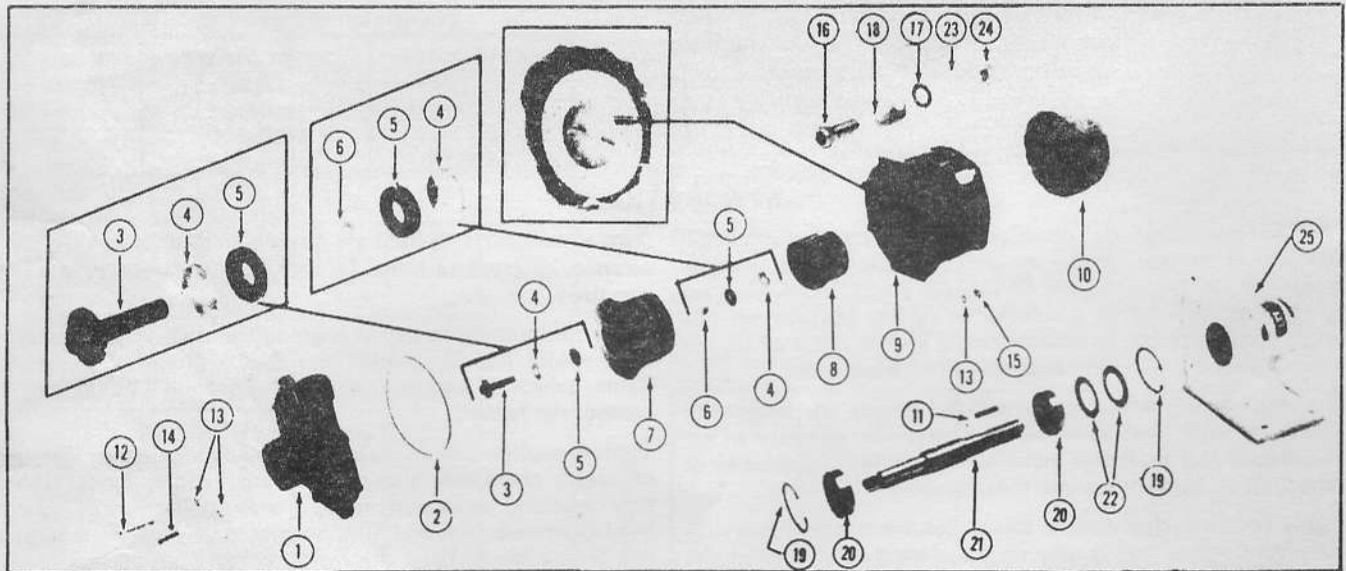

### PARTS LIST

KEY	PART NO.	DESCRIPTION	QTY.	KEY	PART NO.	DESCRIPTION	QTY.
1	17826-0000	Volute Body	1	14		**Screw (#10-32 x 1-1/4")	7
2		*O-Ring (Viton)	1	15		**Hex Nut (#10-32)	8
3		*Cap Bolt (Ryton)	1	16		**Socket Head Bolt (3/8-16 x 1")	4
4		*Seat (Ceramic)	2	17		**Flat Washer (3/8)	4
5		*Bushing (Ryton)	2	18		**Guard	4
6		*Sleeve (Ceramic)	1	19	18729-0000	Retaining Ring	2
7	18243-0000	Impeller/Magnet Ass'y 4.35" Dia.	1	20	92600-0500	Ball Bearing	2
	18243-0001	Impeller/Magnet Ass'y 4.00" Dia.		21	17666-0002	Shaft	1
	18243-0002	Impeller/Magnet Ass'y 3.50" Dia.		22	98036-0290	Spring Washer Set	1
	18243-0003	Impeller/Magnet Ass'y 4.50" Dia.		23		**Lock Washer	4
8		*Bearing (Teflon)	1	24		**Nut (3/8-16)	4
9	18634-0000	Housing	1	25	17649-0001	Pedestal	1
10	18246-0000	Drive Magnet Cup	1		18753-0030	Service Kit	
11	9215-0000	Key	1		18753-0033	Hardware Kit	
12		**Screw (#10-32 x 2")	1		18753-0058	Stainless Steel and Carbon Kit	
13		**Flat Washer (#10)	16				

\*Parts included in Service Kit

\*\*Parts included in Hardware Kit

## DISASSEMBLY

**CAUTION: PUMPS WHICH HAVE HANDLED CORROSIVE, CAUSTIC OR TOXIC FLUIDS SHOULD BE DRAINED AND COMPLETELY FLUSHED PRIOR TO SERVICING. FAILURE TO DO SO MAY CAUSE INJURY.**

1. Remove screws, washers and nuts securing volute body to magnet housing. Remove O-ring from groove in volute.
2. Turn cap bolt, located in eye of impeller, counterclockwise to loosen, and remove bolt and ceramic seat.
3. Remove impeller/magnet assembly with a firm, straight-away pull. Remove two bushings from front and rear of impeller, as well as sleeve. Remove Teflon sleeve bearing from large bore in rear of impeller/magnet assembly. Remove ceramic seat from counterbore of housing.
4. Remove bolts, guards, washers, and nuts securing housing to pedestal. Remove housing.
5. Loosen set screw in drive magnet cup. Prevent pump shaft from turning and rotate drive magnet cup in a counter-clockwise direction to remove.
6. Remove bearing retaining rings with snap ring pliers. Remove spring washers.
7. Press on keyway end of shaft to remove shaft/bearing assembly from pedestal.
8. Remove key from shaft and press bearings from shaft.
9. Clean all parts and inspect for excessive wear. Replacement of Viton O-ring is recommended when servicing pump.

## ASSEMBLY

1. Supporting inner race of bearings, press inboard and outboard bearings onto each end of the shaft, indexing firmly against bearing shoulders.
2. Install outboard bearing retaining ring into groove in shaft drive end of pedestal. Install spring washers with concave side of first washer against retaining ring and second washer with convex side against convex side of first washer. This will position concave side of second spring washer against ball bearing when it is installed.
3. Install shaft/bearing assembly, keyway end first, into pedestal from large flange end, seating firmly against spring washers. Install retaining ring into pedestal against inboard bearing. Use a tube of suitable diameter to press down on retaining ring until it snaps into groove in pedestal to retain shaft/bearing assembly.
4. Hold shaft to prevent rotation and thread drive magnet cup onto shaft in a clockwise direction, until it bottoms firmly against the shaft shoulder. Tighten the set screw in hub of drive magnet cup.
5. Align housing, with flats on housing vertical and secure it to pedestal with bolts, guards, washers, and nuts. Install guards and flat washers under bolt heads, and lock washers under nuts. Torque bolts 43 in.-lbs. Rotate shaft to check for rubbing of parts. If scuffing is detected, check position of drive magnet cup on shaft to make sure it is properly bottomed against shoulder.
6. Install Teflon sleeve bearing into bore in drive end of impeller. Sleeve bearing is taper cut such that, when rolled into a cylinder and properly installed in bore of impeller/magnet assembly, the edges are parallel.
7. Place a small quantity of a good grade of water pump grease on one side of each ceramic seat. Install one seat into counterbore of housing, with grease side against housing. Install second seat over threaded shank of cap bolt, with grease side to back of cap. Place a small quantity of a good grade of water pump grease on the flats of the bushings and install bushings into bore of impeller/magnet assembly, front and back, fitting flats on bushings into corresponding flats in impeller/magnet assembly. Holding bushings in place, insert sleeve into bushings. Taking care not to dislodge bushings or seat, install impeller into housing. Hold impeller firmly or magnetic attraction will snap impeller into housing and dislodge bushings and seat. Place a drop of Loctite 222 on threads of housing. Failure to apply Loctite 222 to bolt will cause bolt to back-out resulting in early pump failure. Insert cap bolt through sleeve in impeller/magnet assembly. Thread into housing until seated firmly, and all seats and bushings are nested, with all flats coinciding. Torque cap bolt to 20 in.-lbs. Overtorquing cap bolt or misalignment of lugs will result in a fracture of the ceramic seats and therefore require their replacement.
8. Install O-ring in volute body. Position volute body against the housing and secure with machine screws, washers and nuts. Place washers under machine screw heads and nuts to protect plastic. Torque machine screws to 24 in.-lbs.

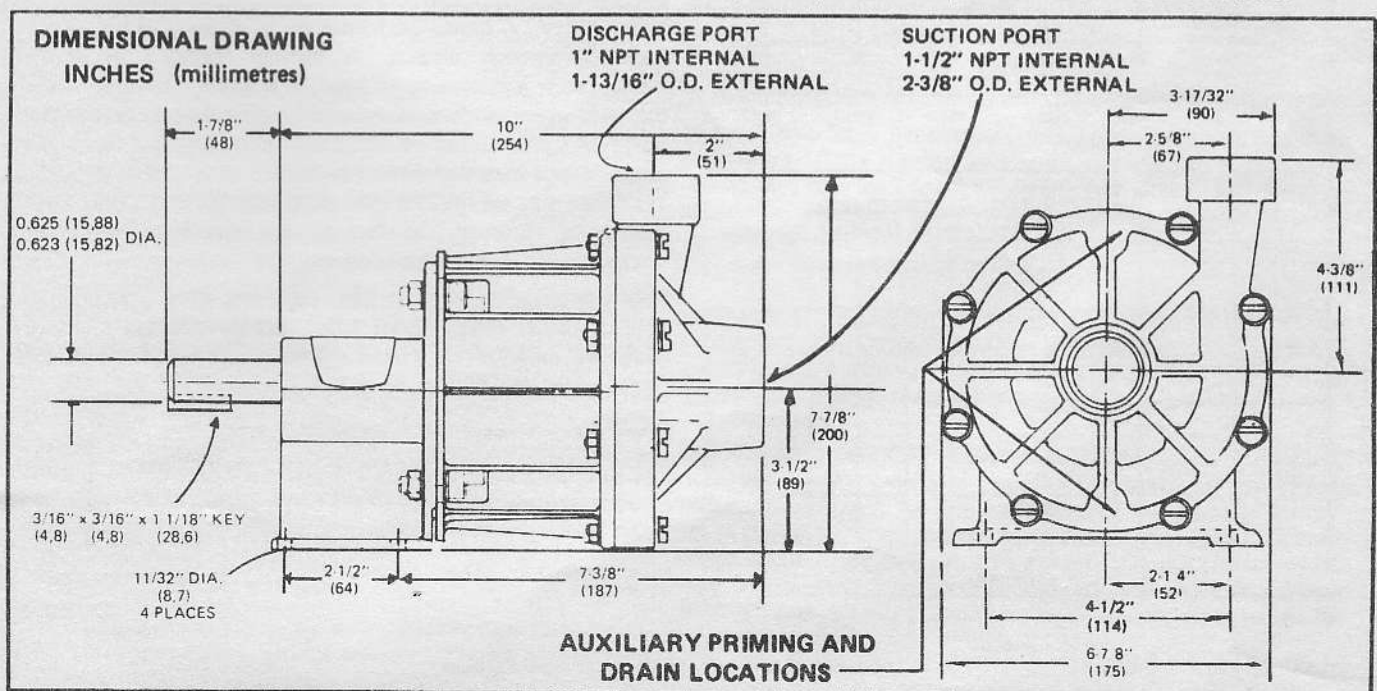

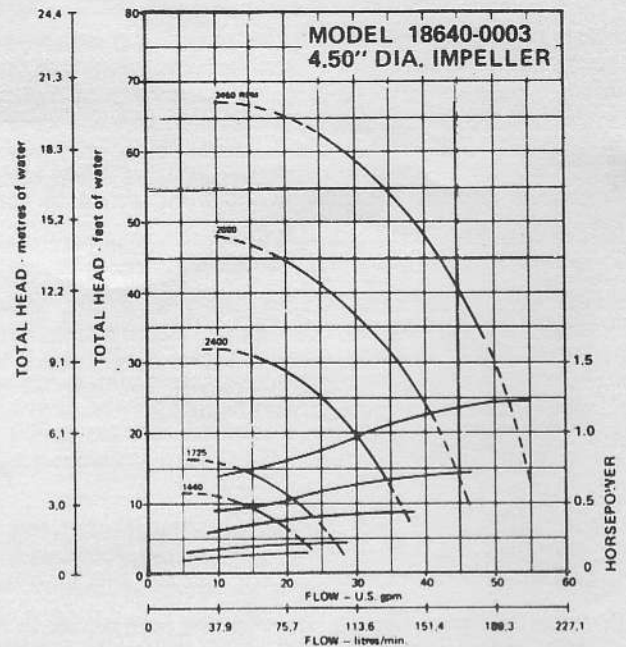
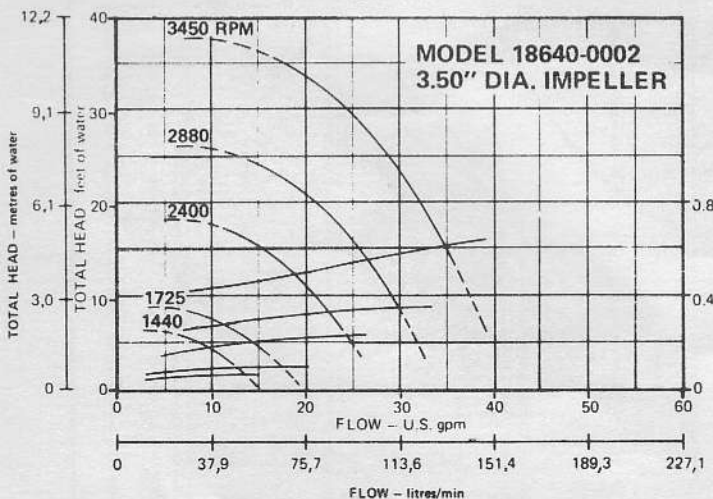
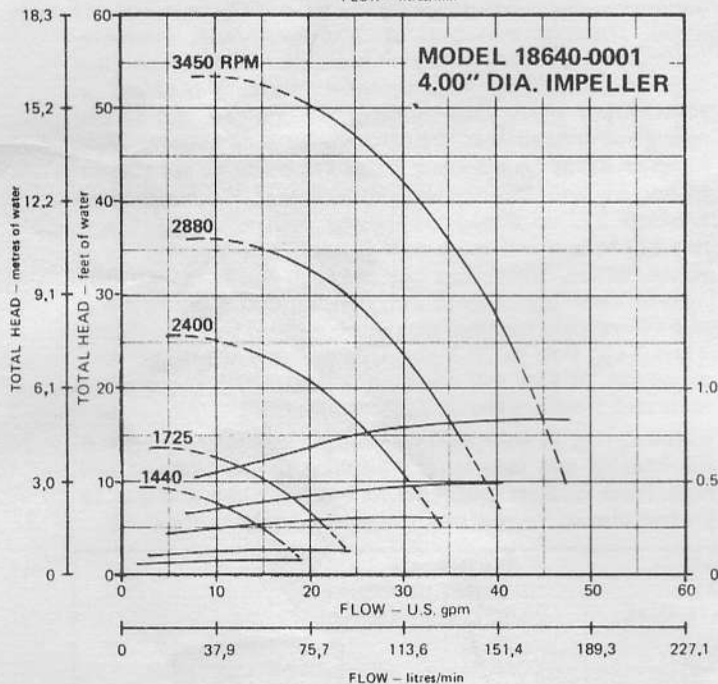
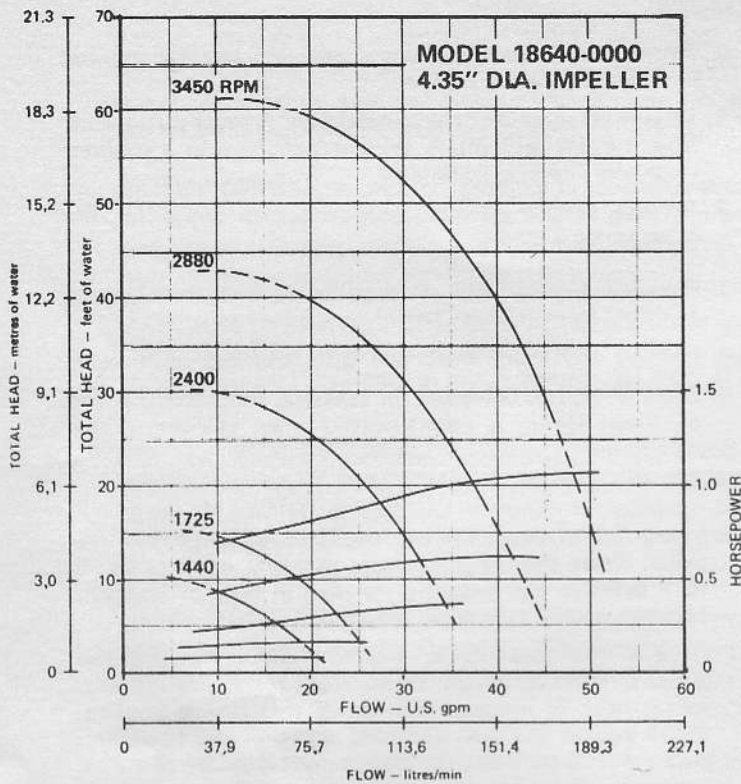

### PUMP HEAD SELECTION

The pump curves shown are a result of test data pumping water at 68° F (20° C). A solid line indicates recommended operating range. The dashed lines indicate marginal applications and, as such, should be referred to the factory for application assistance.

**SPECIFIC GRAVITY** – The above pump curves are based on a 1.0 specific gravity liquid. When pumping liquids with specific gravities greater than 1.0, the horsepower required increases.

This relationship is expressed as follows:

Water horsepower x specific gravity = required horsepower.  
Magnetic drive decoupling may occur if the required horsepower exceeds the following limits:

MOTOR RPM	HORSEPOWER LIMIT
1440	0.91
1725	1.09
2880	1.83
3450	2.19

**VISCOSITY** – Pump performance is directly affected when handling viscous liquids. A distinct increase in required horsepower, a reduction in head, and some reduction in capacity will occur with moderate and high viscosity fluids. When accurate information is required, performance tests under actual conditions should be conducted. It is recommended that fluid viscosity be limited to a maximum of 1000 SSU or 240 centipoise. Consult the factory for assistance when more viscous fluids must be handled.

**THE PRODUCTS DESCRIBED HEREIN ARE SUBJECT TO THE JABSCO ONE YEAR LIMITED WARRANTY, WHICH IS AVAILABLE FOR YOUR INSPECTION UPON REQUEST.**

Locktite PST® is a trademark of Locktite Corporation.

Ryton® is a trademark of Phillips Petroleum Company.

Teflon® and Viton® are trademarks of E. I. Du Pont de Nemours and Company.

**Jabco**  
ITT Fluid Technology Corporation  
1485 Dale Way, P.O. Box 2158  
Costa Mesa, California 92628-2158  
Telephone: (714) 545-8251