



Model 18620-0003

REVERSIBLE PUMP

FEATURES

- Body: Bronze
- Impeller: Nitrile
- Seal: Lip Type
- Motor: Reversible Permanent Magnet Type with Integral Reversing Switch and Fuse
- Ports: 3/4" Garden Hose External
- Height: 3-3/8" (85mm)
- Length: 8-5/8" (172mm)
- Width: 4" (95mm)
- Weight: 5-1/2 lb (2.5 kg) Approx.



Model 18620-0003

WARNING Explosion hazard. Do not pump gasoline, solvents, thinners or other flammable liquids. To do so can cause an explosion resulting in injury or death.

WARNING Explosion hazard. Do not operate with rivets removed from motor case. Explosion resulting in personal injury, death or property damage can occur. Case openings must be sealed to avoid explosion and maintain ignition protected rating.

APPLICATION

Use for circulating and draining bait tank, engine oil changing or general pumping requirements. With a wet impeller, pump will produce a suction lift of about 3 to 4 feet (0.9 to 1.2m) and a lift of about 10 feet (3m) when primed. **BE SURE SUCTION LINES ARE AIRTIGHT.**

INSTALLATION

The pump must be mounted in a dry location - the motor is not waterproof and must not be submerged. SELECTION OF A COOL, VENTILATED location will generally extend pump motor life. The unit can be mounted in any desired position. It is best to mount so that water dripping from loose port connection will not wet the motor. The pump head may be mounted at 90 degree increments on the motor to accommodate plumbing connections as needed.

PLUMBING CONNECTIONS

Pumps have external hose threads and internal 3/8" pipe threads. Use hose that does not kink when bent or collapse due to the suction of the pump. Arrange hoses to trap liquid in pump body to wet the impeller. Wetting the impeller aids in priming and extends impeller life. All hoses must have airtight connections.

HEAD VS. FLOW TABLE

PSI	Total Head		Capacity	
	Feet	Metres	GPM	LPM
2.1	5	1.5	1.8	6.8
4.3	10	3.0	1.7	6.4
8.7	20	6.1	1.6	6.1
17.4	40	12.2	1.2	4.5

Table shows approximate Head-Flow for new pump.

ELECTRICAL CONNECTIONS



WARNING Explosion hazard. If pump is operated in an area containing flammable vapors, wire leads must be joined by insulated mechanical locking connectors. Loose or inadequate wire connections can spark resulting in an explosion. Property damage, injury or death can occur.

Connect black wire to negative (-) terminal of battery. The orange wire should run to a properly sized (see electrical specification) overload protected switch or circuit breaker, with a wire from switch or breaker to positive (+) terminal of battery. Electrical circuit must be independent of all other accessories. Use proper wire size as determined by wire table elsewhere on this sheet.

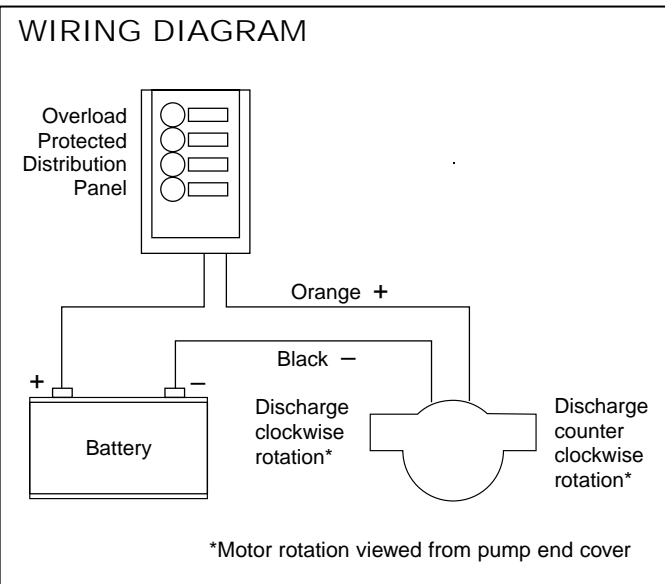

NOTICE: Failure to use proper size fuse may damage motor and void warranty.

ELECTRICAL SPECIFICATIONS

Model No.	Voltage	Amp Draw	Fuse Size
18620-0003	12V DC	7	10 Amp

MINIMUM WIRE SIZES

Wire Length Between Battery and Motor	Wire Gauge
1-10 ft. (3m)	#14
11-20 ft. (6m)	#10
21-30 ft. (9m)	#10

NOTICE: To prevent motor damage, use only multi-strand copper wire in size recommended. DO NOT use ordinary lamp cord or other substitutes.

OPERATION

Flexible impeller pumps must NOT be run dry, as the pumped liquid is the lubricant for the impeller. Observe the outlet and shut off pump as soon as liquid stops flowing.

The pump cannot run against a closed outlet such as encountered when using a garden hose type shut-off nozzle.

Temperature of pumped liquid may be in the range of 45° - 160°F (10° - 70°C).

Pressure for normal operation should not exceed 40 feet of head (17.4 psi).

MAINTENANCE

Check wires and connections to be sure corrosion is not adding additional resistance to the motor circuit and causing a low voltage condition at the motor. Low voltage can inhibit starting and cause fuse to blow. Full voltage should be available to prevent motor damage.

NOTICE: If pump is idle for extended periods, the impeller may stick to the pump body, preventing motor rotation and causing blown fuses. To correct, remove end cover and impeller. Clean body and impeller, then lubricate with water or small amounts of grease before assembly.

If pump is to be in freezing temperatures, drain by loosening end cover.

A service kit, or at least a spare impeller, should be carried aboard to be assured of pumping capability.

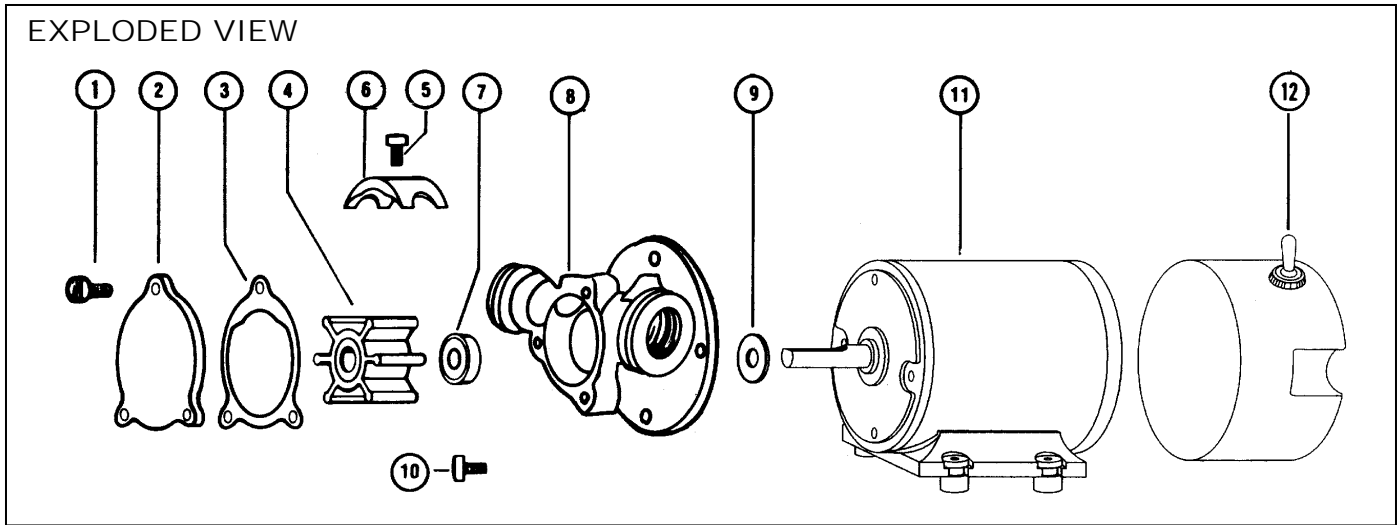

SERVICE INSTRUCTIONS

DISASSEMBLY

1. Remove end cover screws, end cover and gasket.
2. Withdraw impeller.
3. Loosen and remove two slotted hex screws, which attach body to motor.
4. Tap body lightly between ports and remove body from motor.
5. Deform seal and remove from body cavity.
NOTE: Do not tamper with or disassemble motor.

ASSEMBLY

1. Lubricate seal. Deform seal and install in cavity with open side of seal facing impeller.
2. Lubricate motor shaft and install body on motor.
3. Lubricate impeller bore and, aligning flat in impeller with flat on motor shaft, install impeller.
4. Install gasket, end cover and screws.

PARTS LIST

Key	Description	Part Number
1	Screw - End Cover (3 per kit)	91002-0090
2	End Cover	12076-0000
3	Gasket*	7828-0000
4	Impeller, Nitrile*	14750-0003
5	Screw - Cam	91002-0010
6	Cam	809-0000
7	Seal*	93000-0100
8	Body	7824-0000
9	Slinger	6842-0000
10	Screw - Motor Mtg. (3 per kit)	98019-0060
11	Motor 12 Volt	18753-0067
12	Reversing Switch	18753-0652
	Service Kit, Nitrile	90092-0004

*Parts contained in Service Kit

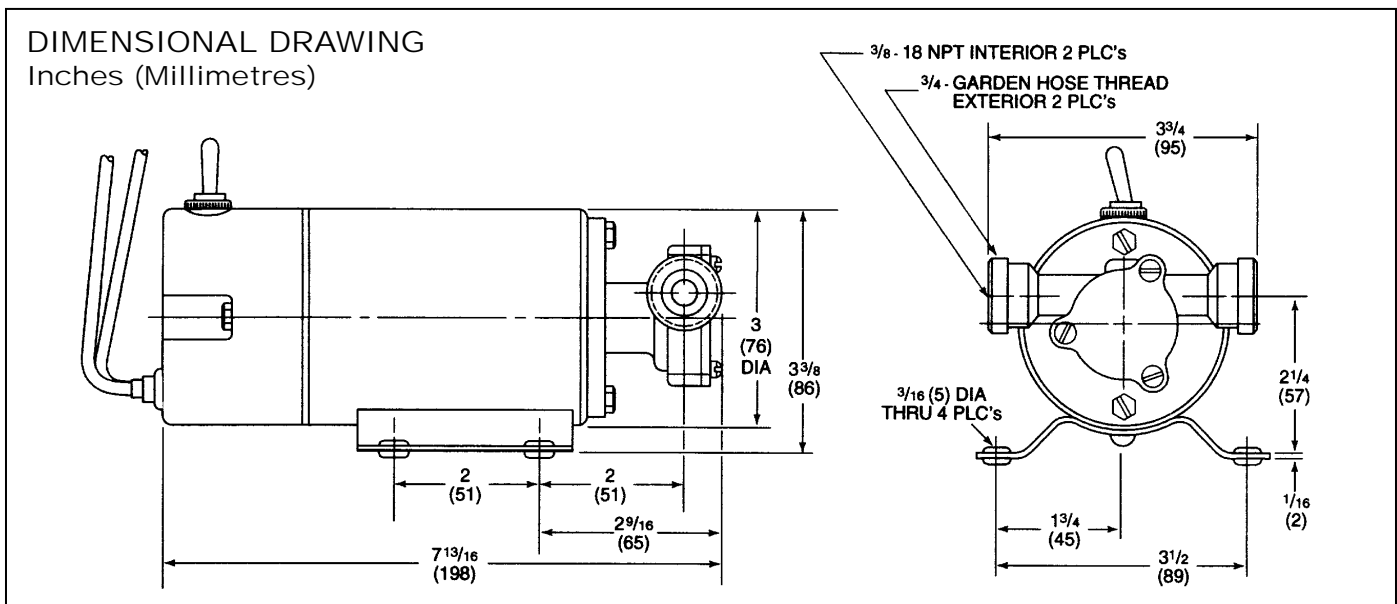

ONE YEAR LIMITED WARRANTY

A. LIMITED WARRANTY:

Jabsco warrants that at the time of shipment, the products manufactured by Jabsco and sold hereunder shall be in conformity with applicable written specifications and descriptions referred to or set forth herein, free from defects in material and, merchantable, and suitable for a particular purpose, provided such is implied by State law under the circumstances of this sale.

B. WARRANTY ADJUSTMENT:

1. Jabsco agrees to repair or furnish a replacement for, but not to remove or install, any product or component thereof which, within one (1) year from date of purchase, shall upon test and examination by Jabsco prove defective within the above warranty. Receipt verifying purchase date is required to obtain adjustment.
2. Buyer shall notify Jabsco of any defect within this warranty no later than ninety (90) days after the defect is discovered.
3. No product will be accepted for return or replacement without the prior written authorization of Jabsco. Upon such authorization, and in accordance with instructions from Jabsco, the product will be returned to Jabsco, shipping charges prepaid by Buyer. Products returned to Jabsco will be addressed as follows:

JABSCO
1485 Dale Way
Costa Mesa, California 92626-3998

Or to such alternate locations as may be designated on the product, its container, or this sheet.
Repair or replacement made under this warranty will be shipped prepaid to Buyer.

C. EXCLUSIONS FROM WARRANTY AND LIMITATION OF LIABILITY:

1. The foregoing warranty is limited solely as set forth herein and applies only for the period designated above.

2. JABSCO SHALL NOT BE LIABLE FOR ANY LOSS, DAMAGE, SPECIAL OR CONSEQUENTIAL DAMAGE OF ANY KIND, WHETHER BASED UPON WARRANTY, CONTRACT, NEGLIGENCE, OR STRICT LIABILITY ARISING IN CONNECTION WITH THE SALE, USE, OR REPAIR OF THE PRODUCT.
3. THE MAXIMUM LIABILITY OF JABSCO IN CONNECTION WITH THIS WARRANTY SHALL NOT IN ANY CASE EXCEED THE CONTRACT PRICE FOR THE PRODUCT CLAIMED TO BE DEFECTIVE OR UNSUITABLE.
4. This warranty does not extend to any product manufactured by Jabsco which has been subjected to misuse, neglect, accident, improper installation, or use in violation of instructions furnished by Jabsco.
5. This warranty does not extend to or apply to any unit which has been repaired or altered at any place other than Jabsco's factory, or by persons not expressly approved by Jabsco, nor to any unit the serial number, model number, or identification of which has been removed, defaced or changed.
6. Components manufactured by any supplier other than Jabsco shall bear only that warranty made by the manufacturer of that product.
7. This warranty applies to products defined as "consumer products" by the Consumer Product Warranties Act as from time to time amended.

D. CONSUMER RIGHTS:

This warranty gives you specific legal rights, and you may have other rights which vary from state to state. Some states do not allow exclusion or limitation of damages.

STANDARD WARRANTY: If the products manufactured and sold hereunder are not Consumer Products, the warranty extended to Buyer shall be as set forth in subparagraphs (A), (B), and (C), **EXCEPT THAT ALL EXPRESS OR IMPLIED WARRANTIES OR MERCHANTABILITY OR SUITABILITY FOR ANY PARTICULAR PURPOSE ARE EXCLUDED.**

Jabsco



ITT Industries
Engineered for life

U.S.A.
Jabsco
20 Icon
Foothill Ranch, CA 92610-3000
Tel: 949.609.5106
Fax: 949.859.1254

UNITED KINGDOM
Jabsco
Bingley Road, Hoddesdon
Hertfordshire EN11 OBU
Tel: +44 (0) 1992 450145
Fax: +44 (0) 1992 467132

CANADA
Fluid Products Canada
55 Royal Road
Guelph, Ontario N1H 1T1
Tel: (519) 821.1900
Fax: (519) 821.2569

JAPAN
NHK Jabsco Company Ltd.
3-21-10, Shin-Yokohama
Kohoku-Ku, Yokohama, 222
Tel: 045.475.8906
Fax: 045.475.8908

GERMANY
Jabsco GmbH
Oststrasse 28
22840 Norderstedt
Tel: +49-40-53 53 73 -0
Fax: +49-40-53 53 73 -11