

PAR™

MODEL 18600-Series

ELECTRIC MARINE TOILET WITH
HOLDING TANK

PRODUCT LINE

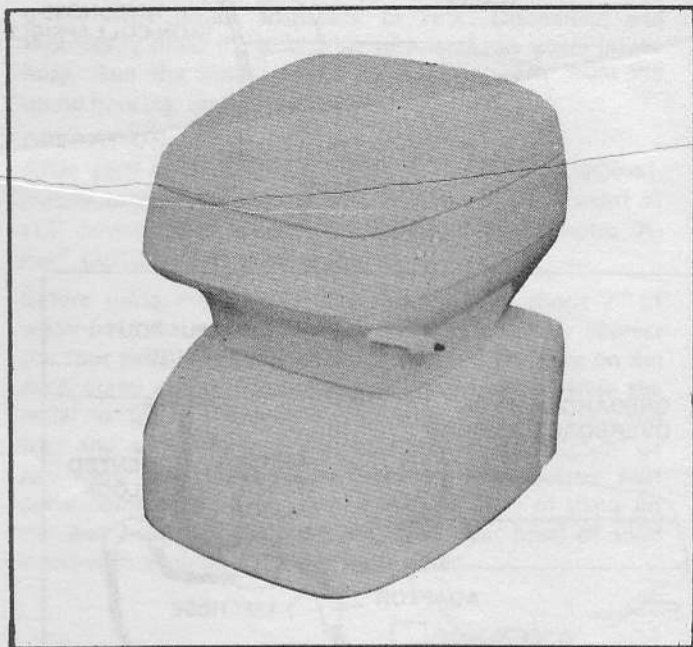

FEATURES

- Self Contained Head and Holding Tank System
- Electric Flush Water Pump
- Easy, Economical Installation
- Meets U.S. Coast Guard Regulations for Type III Device
- Low Amperage Draw
- Optional Macerator/Discharge Pump Available

SPECIFICATIONS

Capacity: 7.8 Gallons
Dry Weight: 25 lb.
Connections: 5/8" Barb Pump Intake
1-1/2" Female Pipe Thread Tank Discharge
5/8" Barb Tank Vent
Electrical: 12 VDC, 3 Amps.

DIMENSIONAL DRAWINGS

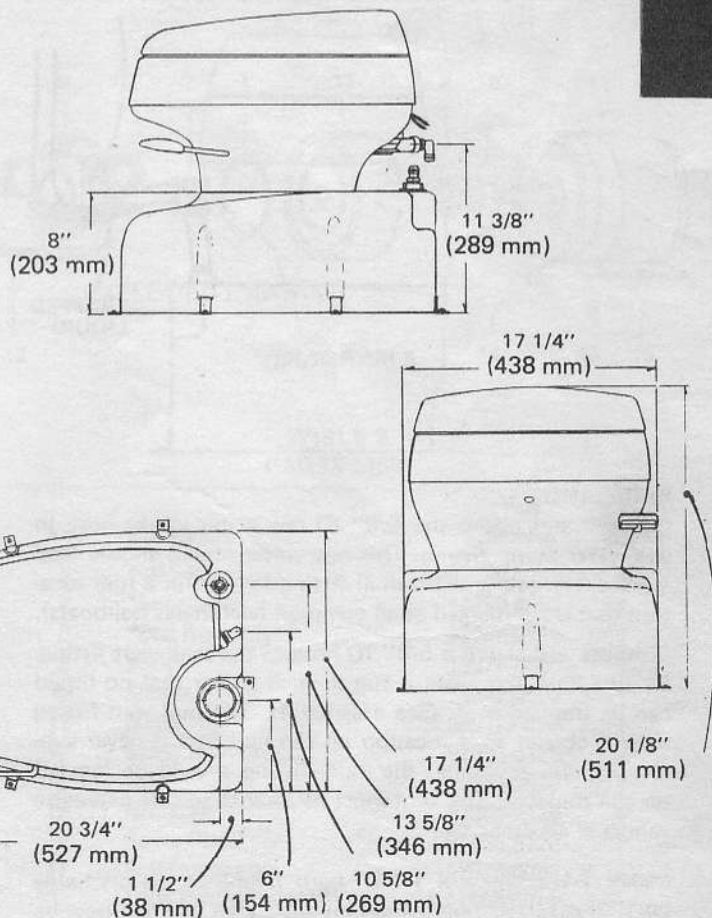

APPLICATIONS

The Bahia Mar is a low profile head mounted on a 7.8 gallon, high density linear polyethylene tank. The Toilet is fitted with a Jabsco self-priming electric flush water pump. Tank and toilet form an attractive, compact solution to current U.S. Coast Guard regulations regarding on board toilet facilities. Overall size is 17-1/2" wide, 21" deep, and 20" high. The unit meets all USCG regulations as a Type III device. It is an easy to install, inexpensive and easy to clean marine sanitation device that is ideal for retrofit or OEM installation.

By 1980 all boats produced before January, 1975 must have a Type I or Type III M.S.D. installed either with, or in place of the original toilet facilities. Currently, all new vessels must have either no toilet facilities, or an M.S.D. that meets USCG regulations. In both the retrofit, and OEM circumstance, the 18600-0000 Bahia Mar offers an excellent system.

The Bahia Mar, like all other Type III devices does not have to be certified to be part of a legal installation. Certification requirements are mandatory for Type I devices only (flow through treatment devices).

The Bahia Mar is available in white, 12VDC model. The unit's rinse and flush operations are controlled by one simple pedal operation. It is constructed with a 5/8" barb vent connection, and a 1-1/2" FPT pump out connection. It has been designed in order that the 18590-Series macerator pump (optional) can be installed in the discharge fitting for easy tank evacuation.

MODEL 18600-SERIES
ELECTRIC MARINE TOILET WITH
HOLDING TANK

INSTALLATION

GENERAL:

The Bahia Mar unit comes preassembled and ready to install. Place the unit in the desired location. Be sure that the location where the tank is positioned is smooth and flat. If there are any sharp or abrasive areas, smooth to prevent damage to the tank. The surface must be flat to prevent any rocking of the toilet/tank unit and tank deformation when the tank is partially full. Place each of the six mounting brackets in the six indentations on the tank. Mark the hole location in each tab on the surface that the Bahia Mar will be mounted on. Drill 6 holes using a 5/32" diameter drill bit. If the cabin sole is less than 1/2" thick, it may be necessary to through bolt the mounting tabs using #10 stainless steel machine screws, nuts, and washers. Reposition the head/holding tank and fasten to the cabin sole.

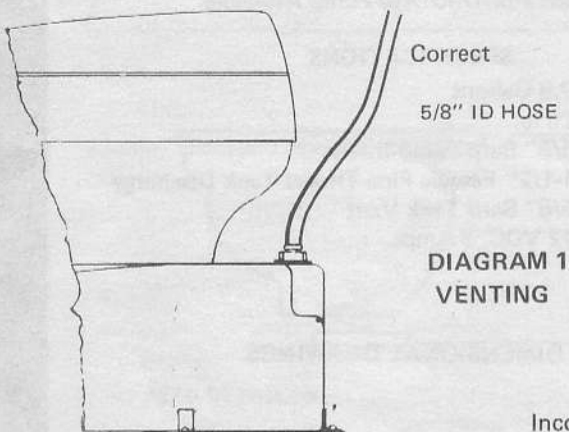

DIAGRAM 1
VENTING

DOCKSIDE
DECK PUMPOUT
ONLY

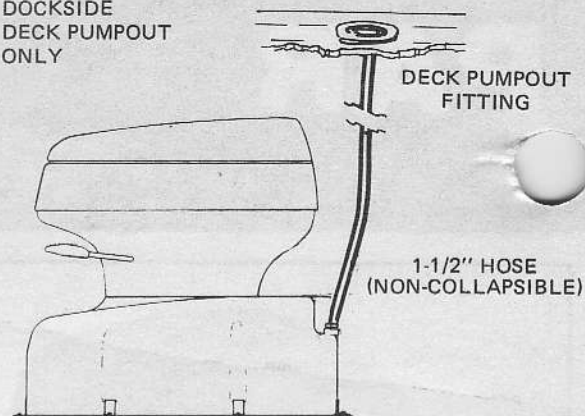

DIAGRAM 2

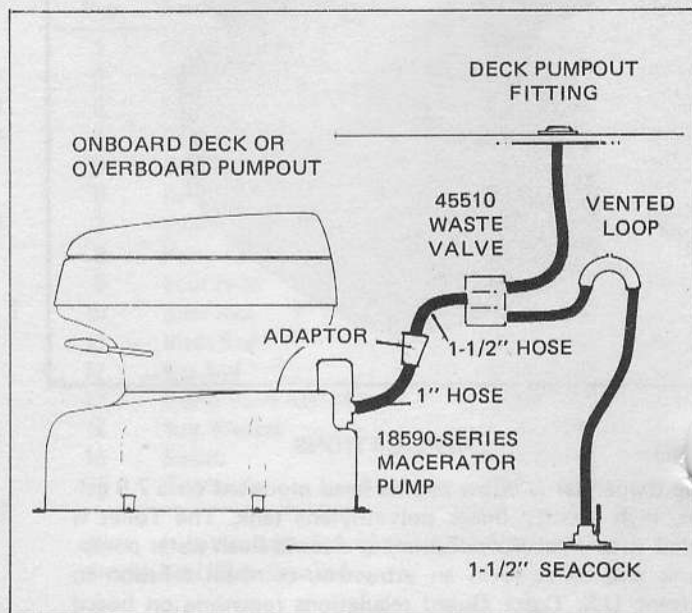

DIAGRAM 3

PLUMBING:

Connect and clamp the 5/8" ID raw water intake hose to the water pump fitting. This raw water source should lead from a seacock and thruhull fitting located in a hull location that is submerged at all common heel angles (sailboats).

Connect and clamp a 5/8" ID hose to the tank vent fitting. Be sure that this hose is run in such a way that no liquid can be trapped in it. (See diagram 1). The hull vent fitting should be run to a location on the hull that is never submerged. On sailboats, the vent fitting should be located on the transom. The vent must be clear to release explosive vapors at all times.

Install 1-1/2" MPT x 1-1/2" barb fitting in the discharge port. The 1-1/2" non-collapsible discharge line can now be connected and clamped. Diagrams 2 and 3 show typical discharge installations. If the optional 18590-Series macerator is used as shown in Diagram #3 the discharge will be 1" ID hose.

ELECTRICAL:

The Bahia Mar toilet is very simple to install electrically. The positive motor lead is equipped with a fuse and is the orange wire. The black motor lead is connected to the negative battery lead. The correct wire gauge for battery lead lengths is given in Table 1. Do not use twist type wire connectors. Use only crimp type butt connectors.

MINIMUM WIRE SIZES
TABLE 1

Connection Length Between Battery and Motor	12V.
1-10 ft (3m)	# 14
11-20 ft (6m)	# 12
21-30 ft (9m)	# 10

CAUTION: Use only multi-strand copper wire in size recommended. DO NOT use ordinary lamp cord or other substitutes. Use 5 amp fuse.

MAINTENANCE:

Each time the tank is pumped out, rinse the tank with ample amounts of fresh water and pump the tank again.

Do not use harsh detergents or abrasive chemicals to clean the toilet and tank. Liquid detergents and cleansers should be used.

WINTER PROTECTION:

Empty and thoroughly flush the holding tank. Add one pint of ethylene glycol antifreeze to tank. Disconnect and thoroughly drain the discharge, vent, and raw water intake hose. Run the pump briefly to evacuate water from the pump housing. Shut all seacocks.

OPERATION:

After each tank pumpout, charge the tank with approximately one gallon of water and an appropriate amount of ITT Jabsco "PAR Chem" (38102-0000) or "Dissolve 'A-Pak'" (38100-0000) toilet chemical.

Before using the tank be sure the bowl has about 2" of water in it. After use, close the toilet lid and fully depress the foot pedal. This will open the trap and also turn on the flush pump motor. Flush for about 5 seconds. Release the pedal to 1/2 of the depressed position. This will close the trap and allow the operator to pump about 1/2"-1" of raw water into the bowl to cover the trap. Release foot pedal completely. (See Diagram #4). A layer of tissue on the wet bowl prior to use, will help clear bowl of solid waste with a minimum use of flush water.

DIAGRAM 4

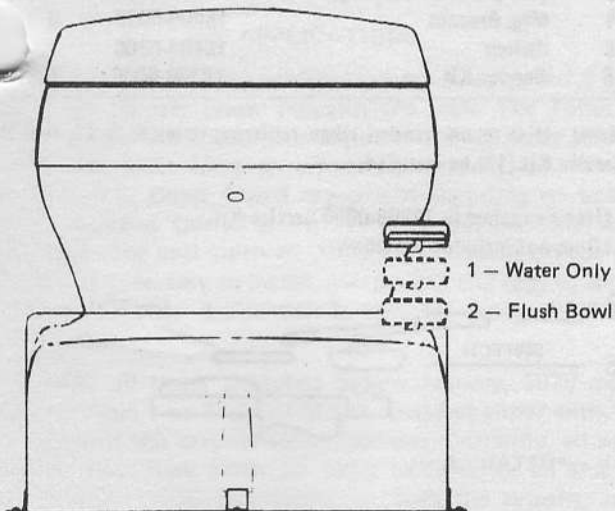

SERVICE:

The Bahia Mar is extremely easy to service. The top housing can be lifted off (with removal of a single screw) to expose all internal functional parts. For much of the services it is not necessary to disturb plumbing connections or remove the toilet from the holding tank, and many of the components are replaced as a unit for easy servicing.

A. LID OR SEAT REPLACEMENT

1. Using a 9 inch #2 Phillips screwdriver with a 4 or 5 inch blade, remove screw located within recess under front contour.
2. Lift lid and seat and pull front of top housing away from bowl about two inches. Close lid and pressing through rear slot disengage upper housing and lift free.

3. Push out pivot pins from inside upper housing to separate seat and lid.

B. DUMP VALVE AND BOWL REPLACEMENT

1. Disconnect water inlet line.
2. Remove upper housing assembly as in "A" above.
3. Remove toilet lower housing from tank.
4. Remove three screws from underside of lower housing. Use of #2 Phillips screwdriver with at least a 6-1/2 inch blade.
5. Disconnect hose from bowl to water pump.
6. Remove bowl from housing assembly.
7. Snap up and remove pedal from pedal level rod and pull dump valve assembly out from the inside of the toilet lower housing.
8. Assemble by reversing steps for disassembly.

C. MOTOR AND PUMP REPAIR

1. Disconnect water inlet line.
2. Remove upper housing assembly as in Step "A" above.
3. Disconnect water discharge hose and motor leads.
4. Remove mounting screws (4) from pump base and remove pump/motor assembly from the toilet.
5. See Diagram #5 for disassembly diagram and Table #2 for Parts List.

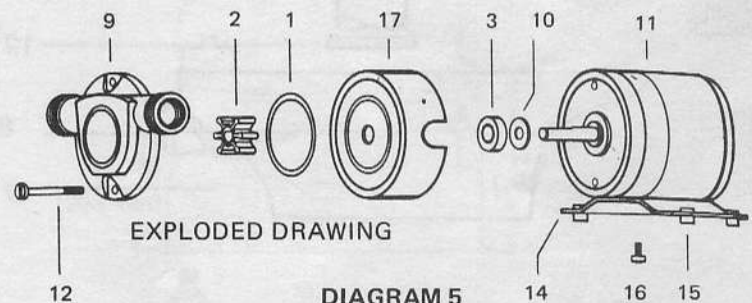
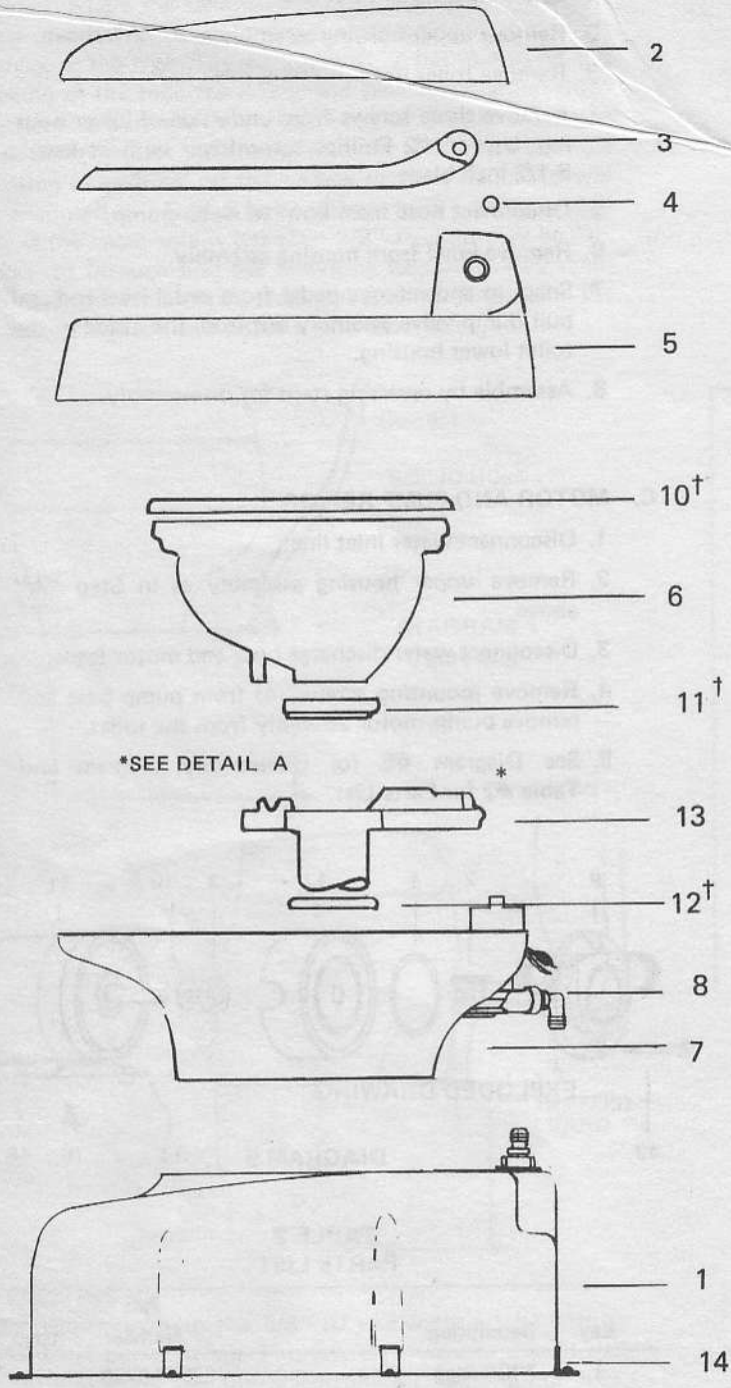

TABLE 2
PARTS LIST

Key	Description	Part Number	Qty.
1	*"O" Ring	92000-0750	1
2	*Impeller	14750-0003	1
3	*Seal Assembly	92700-0910	1
9	Body	12375-0000	1
10	Slinger	6342-0000	1
11	Motor	98012-0020	1
12	Screw (End Cover)	91003-0120	2
14	Base	6357-0020	1
15	Grommet	92900-0120	4
16	Screw (Base)	91053-0120	2
17	Seal Housing	12314-0000	1
	Total Pump Assembly	12460-0011	-
	Pump Head Replacement	12317-0000	-
	Service Kit	90158-0051	-

*Parts Supplied in Service Kit

EXPLODED VIEW DIAGRAM



PARTS:

TABLE NO. 3

Key	Description	Part Number	Qty.
1	Holding Tank	18603-0000	1
2	Lid	18047-0000	1
3	Seat	18046-0000	1
4	Pivot Pin	18034-0000	1
5	Upper Housing	18036-0000	1
6	Bowl	18043-0000	1
7	Lower Housing	18605-0000	1
8	Pump Assembly ††	See Table #2	1
9	Foot Pedal †	18041-0000	1
10	Bowl Seal †	18044-0000	1
11	Blade Seal †	18042-0000	1
12	Gas Seal †	18039-0000	1
13	Dump Valve Assembly	18606-0000	1
14	Mtg. Bracket	18609-0000	6
15	Switch	18604-0000	1
16	Service Kit	18309-0000	1

Note: It is recommended when replacing items 6 & 13, that the Service Kit (16) be installed.

†Items supplied in 18309-0000 Service Kit.
 ††Does not include port elbow.

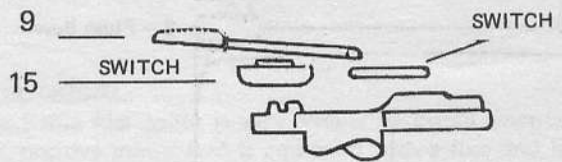

*DETAIL A

ITT JABSCO

MARC Division

International Telephone and Telegraph Corporation
 1485 Dale Way, Costa Mesa, California 92626

Telephone: (714) 545-8251