

JABSCO

Models 18540-SERIES Ped. 18570-SERIES M.P.U.

Models 18540-SERIES Ped., 18570-SERIES M.P.U.

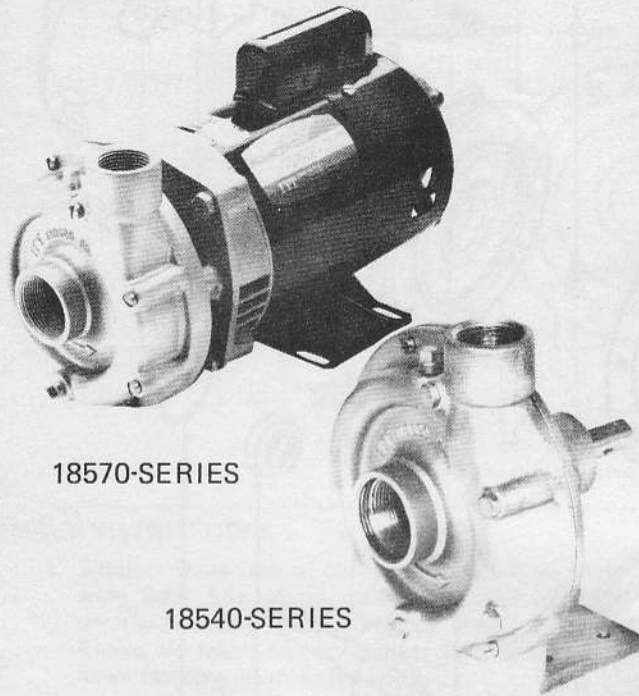

BRONZE CENTRIFUGAL FEATURES

Volute Body:	Bronze	
Ports – Inlet:	1-1/4" NPT	
Discharge:	1" NPT	
Impeller:	Bronze	
Pedestal:	Bronze	
Shaft:	MPU – 316 SS Ped. – 304 SS	
Seal:	Carbon/Ceramic Face with Buna-N	
Motor:	1/3 HP, 115/1/60, Open Drip Proof, 3450 RPM	
	1/2 HP, 115/230/1/60, Open Drip Proof, 3450 RPM	
	3/4 HP, 115/230/1/60, Open Drip Proof, 3450 RPM	
Weight:	18570-0000 – 25-1/2 lb	(11,6 kg)
	18570-0001 – 25-3/4 lb	(11,7 kg)
	18570-0002 – 28-5/8 lb	(13 kg)
	18540-0000 – 11-1/8 lb	(5 kg)
	18540-0001 – 11-1/8 lb	(5 kg)
	18540-0002 – 11-1/8 lb	(5 kg)

⚠ MOTOR WARNING



MOTOR CAN SPARK.
EXPLOSION & DEATH
CAN OCCUR.
DO NOT USE WHERE
FLAMMABLE VAPORS
ARE PRESENT.

MODELS AVAILABLE MOTOR PUMP UNITS

MOTOR	IMPELLER DIAMETER	BUNA SEAL
1/3 HP	3"	18570-0000
1/2 HP	3-1/2"	18570-0001
3/4 HP	3-3/4"	18570-0002

PEDESTAL PUMP UNITS

N/A	3"	18540-0000
N/A	3-1/2"	18540-0001
N/A	3-3/4"	18540-0002

DESCRIPTION

The Jabsco bronze centrifugal pumps are designed for continuous duty service. The close coupled, compact motor pump units are equipped with ball bearing motors and stainless steel shafts and have service factors of 1.5 or greater. The pedestal mounted pumps are equipped with two single row ball bearings lubricated for long heavy duty service.

Mechanical rotary seals have carbon/ceramic seal faces with Buna N seal parts. Unlike the usual Jabsco pump, the Jabsco centrifugal pumps are *not* self-priming. Normal installation is flooded suction, that is, with the pump below the source liquid level so that liquid flows by gravity to the pump. The pump may be located above the liquid source, if a check valve or foot valve is installed at the beginning of the suction line; and, the pump and entire suction line is filled with liquid; and, all air is bled from the suction system. The pump will lift water approximately 15 feet on the suction side when primed and

will maintain its prime, as long as the foot or check valve functions as it should, without leaking. If the check valve leaks, the pump will not reprime, and must be manually primed in order to resume operation.

Published performance curves are based on pumping water, at 68°F. Referring to the performance curves for the pedestal mount pump, the maximum horsepower at a given speed is required at open discharge. As the head (pressure) against which the pump operates increases, the horsepower decreases.

Liquids of higher specific gravity (weight) than water require more power to generate the same performance available with water. The horsepower requirement increases directly as the increase in specific gravity. Thus, for a pedestal mount pump we would multiply the horsepower shown for water by the specific gravity of the liquid to be pumped, to determine the horsepower required to do the job.

It is not possible to increase the horsepower of a close coupled motor pump unit, therefore, to pump a liquid of higher specific gravity, with the centrifugal motor pumps, the capacity must be limited by restricting the discharge to stay within the horsepower available. In other words, the discharge must be throttled to the extent that the motor full load amperage rating, found on the motor label, is not exceeded.

In all installations, make sure the suction is not restricted. Do not use an elbow fitting in the pump intake port. Starved suction can result in cavitation which will damage the pump and cause performance deterioration.

Viscous or thick liquids are difficult to pump with a small centrifugal pump. Do not attempt to pump liquids with a viscosity exceeding 1500 SSU (SAE 30 WT OIL at 75°F) with a centrifugal pump. Consider, instead, the Jabsco flexible impeller pump or gear pump.

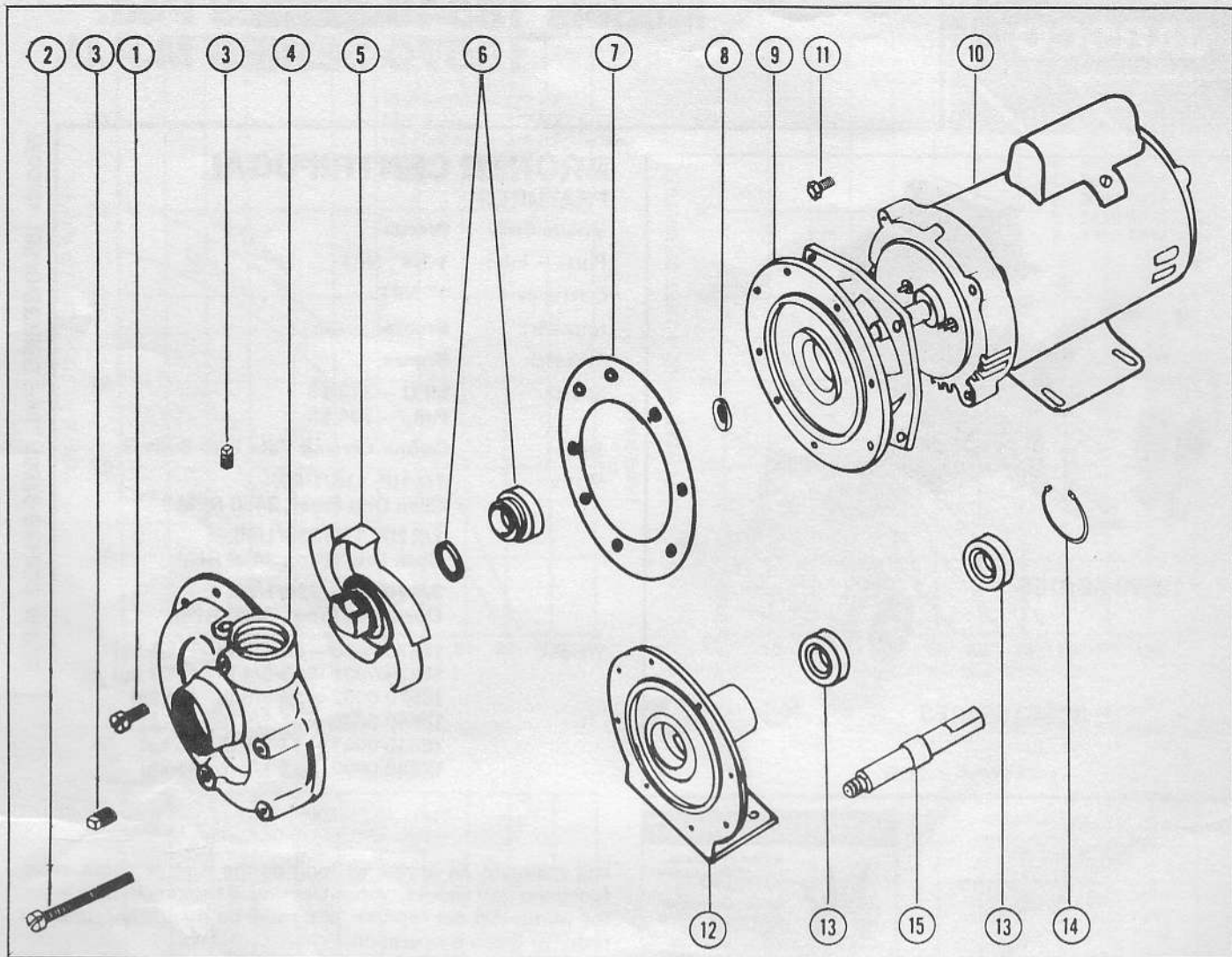

PARTS LIST

KEY	COMMON	QTY.	PART NUMBER	KEY	MOTOR PUMP UNIT	QTY.	PART NUMBER
1	Screw (Short)	5	91004-0020	9	Seal Hsg.	1	18575-0000
2	Screw (Long)	3	91004-0080	10	Motor – 1/3 HP 115/1/60	1	93004-2608
3	Pipe Plug	2	92650-0040		– 1/2 HP 115/230/1/60		93004-2609
4	Volute	1	18574-0000		– 3/4 HP 115/230/1/60		93004-2610
5	Impeller – 3.00 Dia.	1	18576-0000	11	Bolt (Motor)	4	91094-0070
	– 3.50 Dia.		18576-0001		SHIM (Not Shown)	1	18578-0000
	– 3.75 Dia.		18576-0002		PEDESTAL UNIT		
6	Seal Assembly – Buna	1	96080-0375	12	Pedestal	1	18544-0000
7	Gasket	1	18577-0000	13	Ball Bearing	2	92600-0460
8	Slinger	1	3180-0000	14	Retaining Ring	1	18719-0000
				15	Shaft	1	18579-0000

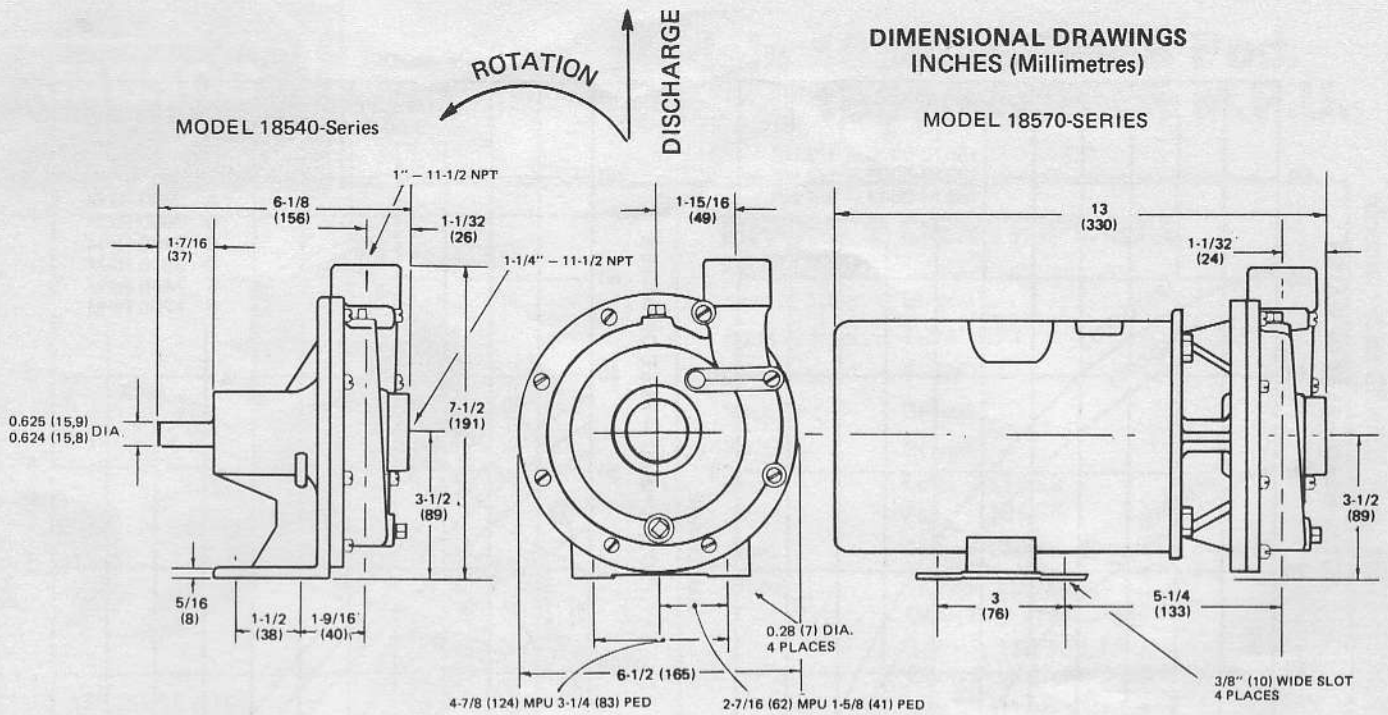

ASSEMBLY INSTRUCTIONS

- | | |
|--|--|
| <p>Ped 1. Support inner race of ball bearing, lubricate shaft with light film of oil, press drive end of shaft through bearing firmly against shoulder. (Care should be taken not to damage threads on shaft when pressing on threaded end.)</p> <p>Support inner race of second ball bearing and press threaded end of shaft through bearing firmly against shoulder.</p> | <p>Ped MPU 5. Install ceramic seat into seat cup with polished surface outwards. Lubricate seat cup with water and press into impeller bore with polished ceramic surface facing out. Do not scratch or mar seat surface.</p> |
| <p>Ped 2. Support flange side of bearing pedestal, insert threaded end of shaft/bearing assembly into pedestal. Seat inner bearing firmly against inner bearing shoulder. Install retaining ring into groove in pedestal against outer bearing.</p> | <p>MPU Ped 6. Attach seal housing to motor with 4 bolts.</p> <p>MPU Ped 7. Apply Loctite*** to shaft threads and install impeller into shaft until it bottoms firmly against shaft shoulder. Motor pump unit normally requires one shim between impeller and shaft shoulder.</p> |
| <p>Ped MPU 3. Install slinger on shaft within 1/4" of bearing or motor.</p> | <p>Ped MPU 8. Install gasket against mounting flange and secure volute body to flange face with 3 long screws and 5 short screws.</p> |
| <p>Ped MPU 4. Apply light coat of Permatex** or equivalent sealant on O D of seal. With large flange face of pedestal and multi-hole flange of seal housing up, install seal, carbon face outwards, using 1-5/8" O D x 1-3/8" I D tubing 1" long to press against flange of seal. Seat firmly into seal bore.</p> | <p>Ped MPU 9. Make sure priming plug and drain plug are secure and sealed in volute body.</p> <p>Ped MPU 10. Rotate shaft to make sure there is no metal contact between body and impeller.</p> |

DISASSEMBLY

- | | |
|---|--|
| <p>MPU Ped 1. Remove 8 body screws and body.</p> | <p>Ped 5. Remove retaining ring from bearing housing.</p> |
| <p>MPU Ped 2. Remove body gasket.</p> | <p>Ped 6. Place block of wood on shaft threaded end to protect threads, support pedestal and press shaft and bearing assembly out of pedestal.</p> |
| <p>MPU Ped 3. Prevent shaft from turning. Pedestal Pump — Grasp shaft with vice grip pliers. MPU — Insert screwdriver in slot in end of motor shaft after removing end cap. Grasp nose of impeller with vice-grip pliers and rotate impeller counterclockwise to unthread from shaft.</p> | <p>Ped 7. Support flange face of pedestal and using a 1-3/8" dia. dowel or plastic pipe, press seal from pedestal.</p> <p>Ped 8. Place two metal bars between bearings to support bearing while pressing shaft out of bearing. Use a wooden block to protect threads when removing shaft from inner bearing.</p> |
| <p>MPU Ped 4. Use a pointed tool to remove seal seat from rear of impeller.</p> | <p>MPU 9. Remove seal housing from motor. Use a 1-3/8" dia. dowel or plastic pipe to press seal from pedestal.</p> |

Permatex** is a trademark of Permatex Company.

Loctite PST*** is a trademark of Loctite Corporation.

MODEL 18570 SERIES

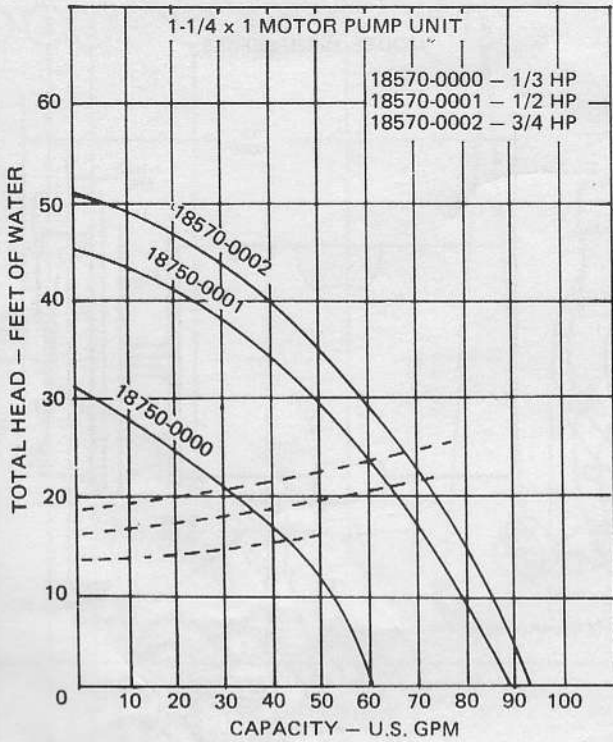

1.2 U.S. GAL. = 1 IMP. GAL.
1 U.S. GAL. = 3,785 LITRES

4,546 LITRES = 1 IMP. GAL.
2.31 FT = 1 PSI

MODEL 18540 SERIES

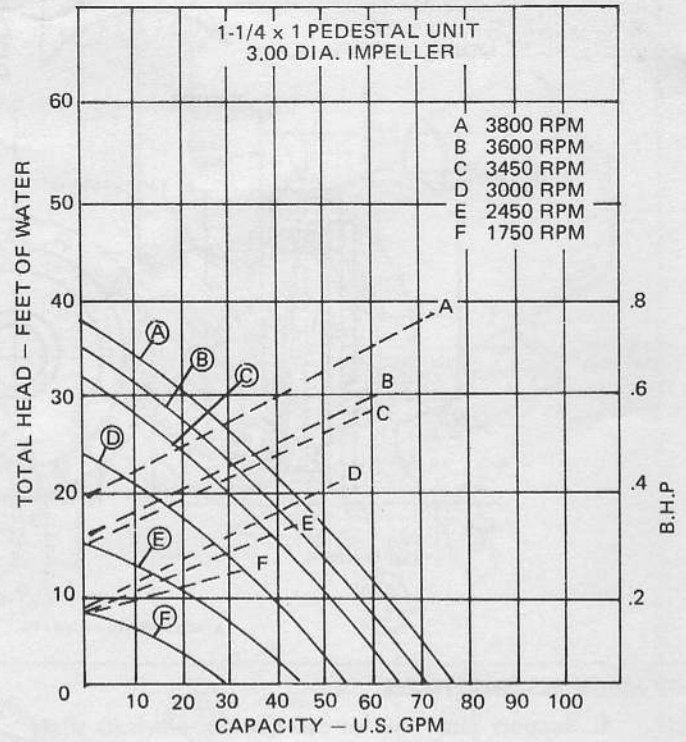

14.22 PSI = 1 kg/cm²
32.85 FT/HD = 1 kg/cm²

MODEL 18540-0001

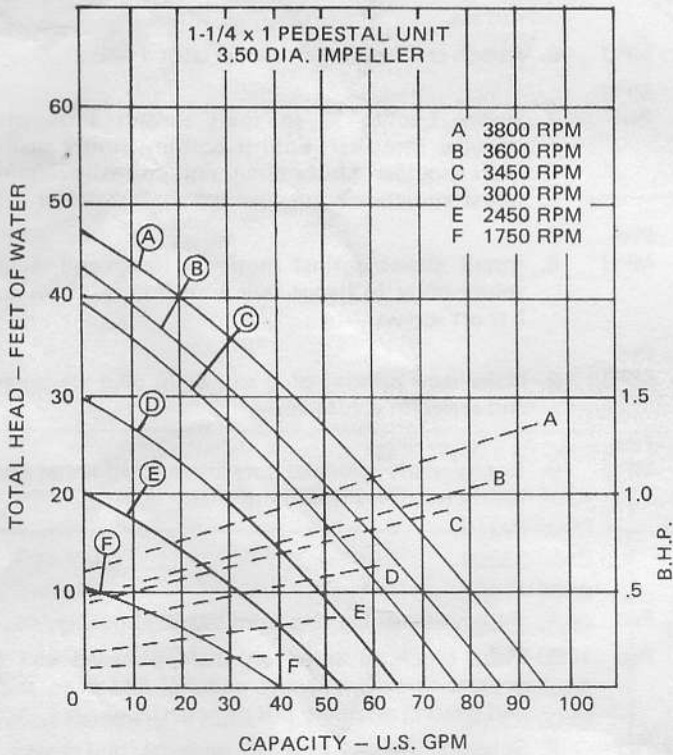

MODEL 18540-0002

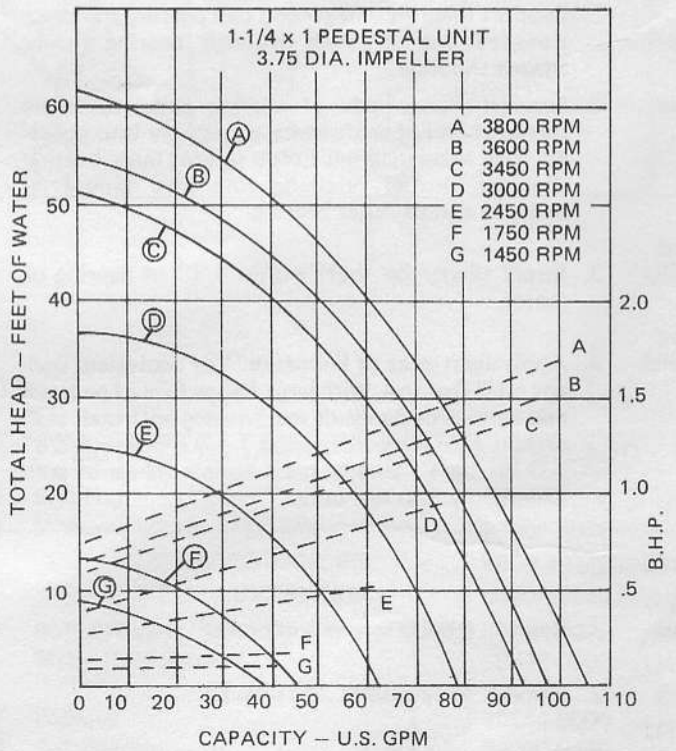

THE PRODUCTS DESCRIBED HEREIN ARE SUBJECT TO THE JABSCO ONE YEAR LIMITED WARRANTY, WHICH IS AVAILABLE FOR YOUR INSPECTION UPON REQUEST.

Jabco
ITT Fluid Technology Corporation
1485 Dale Way, P.O. Box 2158
Costa Mesa, CA 92628-2158
Telephone: (714) 545-8251