

**JABSCO**

# Model 18530-0000—Pedestal Mount Model 18560-0000—Motor Pump Unit



MODEL 18560-0000



MODEL 18530-0000

## CENTRIFUGAL PUMP

### FEATURES

Volute Body:	Bronze
Ports: Inlet:	3/4" NPT
Discharge:	1/2" NPT
Impeller:	Bronze
Pedestal:	Bronze
Shaft:	MPU 316 SS PED 304 SS
Seal:	Carbon/Ceramic Face with Buna-N
Motor:	1/3 HP, 115/1/60, 3450 RPM, Open Drip Proof, Thermal Overload Protected, No Cord.
Weight:	18530-0000 — 8 lb (3,6 kg) 18560-0000 — 21-1/2 lb (9,8 kg)

Model 18530-0000 — Pedestal Mount,  
Model 18560-0000 — Motor Pump Unit

### ⚠ MOTOR WARNING



MOTOR CAN SPARK.  
EXPLOSION & DEATH  
CAN OCCUR.  
DO NOT USE WHERE  
FLAMMABLE VAPORS  
ARE PRESENT.

MODEL	DESCRIPTION
18530-0000	Pedestal Mount with Buna-N Seal
18560-0000	Motor Pump Unit with Buna-N Seal

## DESCRIPTION

The Jabsco bronze centrifugal pumps are designed for continuous duty service. The close coupled, compact motor pump units are equipped with ball bearing motors and stainless steel shafts and have service factors of 1.5 or greater. The pedestal mounted pumps are equipped with two single row ball bearings lubricated for long heavy duty service.

Mechanical rotary seals have carbon/ceramic seal faces with the choice of Buna N or Viton seal parts for application versatility. Unlike the usual Jabsco pump, the Jabsco centrifugal pumps are *not* self priming. Normal installation is flooded suction, that is, with the pump below the source liquid level so that liquid flows by gravity to the pump. The pump may be located above the liquid source, if a check valve or foot valve is installed at the beginning of the suction line; and, the pump and entire suction line if filled with liquid; and, all air is bled from the suction system. The pump will lift water approximately 15 feet on the suction side when primed and will maintain its prime, as long as the foot or check valve functions as it should, without leaking. If the check valve leaks, the pump will not reprime, and must be manually primed in order to resume operation.

Published performance curves are based on pumping water, at 68°F. Referring to the performance curves for the pedestal mount pump, the maximum horsepower at a given speed is required at open discharge. As the head (pressure) against which the pump operates increases, the horsepower decreases.

Liquids of higher specific gravity (weight) than water require more power to generate the same performance available with water. The horsepower requirement increases directly as the increase in specific gravity. Thus, for a pedestal mount pump we would multiply the horsepower shown for water by the specific gravity of the liquid to be pumped, to determine the horsepower required to do the job.

It is not possible to increase the horsepower of a close coupled motor pump unit, therefore, to pump a liquid of higher specific gravity, with the centrifugal motor pumps, the capacity must be limited by restricting the discharge to stay within the horsepower available. In other words, the discharge must be throttled to the extent that the motor full load amperage rating, found on the motor label, is not exceeded.

In all installations, make sure the suction is not restricted. Do not use an elbow fitting in the pump intake port. Starved suction can result in cavitation which will damage the pump or cause performance deterioration.

Viscous or thick liquids are difficult to pump with a small centrifugal pump. Do not attempt to pump liquids with a viscosity exceeding 1500 SSU (same viscosity as SAE 30 wt. oil at 75°F) with a centrifugal pump. Consider, instead, the Jabsco flexible impeller pump or gear pump.

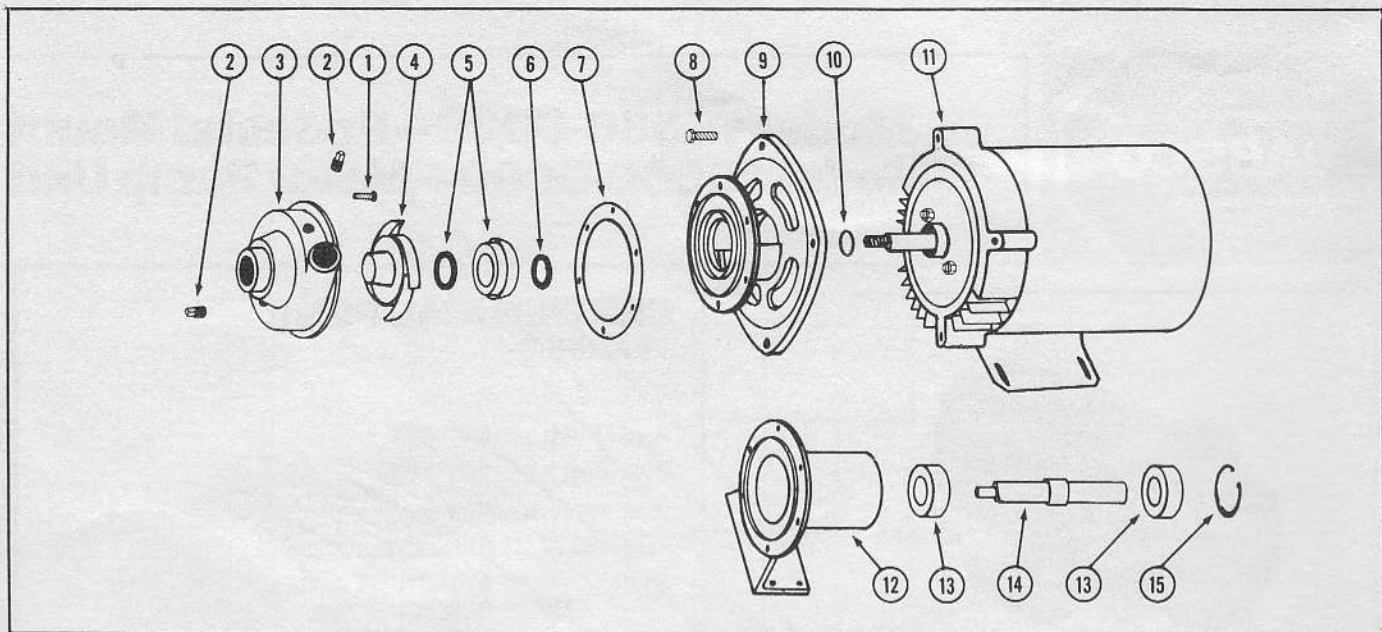

### PARTS LIST

KEY	DESCRIPTION	PART NUMBER	QTY
<b>Common Parts</b>			
1	Screw	91094-0251	8
2	Plug	92650-0040	2
3	Volute Body	18564-0000	1
4	Impeller	18566-0000	1
5	Seal Assemby — Buna Viton	96080-0375 96080-0378	1
6	Slinger	3286-0000	1
7	Gasket	18567-0000	1
<b>Motor Pump Unit</b>			
8	Bolt	91094-0070	4
9	Seal Housing	18565-0000	1
10	Shim	18578-0000	1
11	Motor — 1/3 HP 115/1/60	93004-2608	1
<b>Pedestal Unit</b>			
12	Pedestal	18534-0000	1
13	Bearing	92600-0460	2
14	Shaft	18579-0000	1
15	Retaining Ring	18719-0000	1

### DISASSEMBLY INSTRUCTIONS

- |     |  |     |  |
|-----|--|-----|--|
| MPU |  | Ped | 5. Remove retaining ring from bearing housing.   |
| Ped | 1. Remove 8 body screws and body.  | Ped | 6. Place block of wood on shaft threaded end to protect threads, support pedestal and press shaft and bearing assembly out of pedestal.  |
| MPU |  | Ped | 7. Support flange face of pedestal and using a 1-3/8" dia. dowel or plastic pipe, press seal from pedestal.  |
| Ped | 2. Remove body gasket.   | Ped | 8. Place two metal bars between bearings to support bearing while pressing shaft out of bearing. Use a wooden block to protect threads when removing shaft from inner bearing. |
| MPU |  | MPU | 9. Remove seal housing from motor. Use a 1-3/8" dia. dowel or plastic pipe to press seal from pedestal.  |
| Ped | 3. Prevent shaft from turning. Pedestal Pump — Grasp shaft with vice grip pliers. MPU — Insert screwdriver in slot in end of motor shaft after removing end cap. Grasp nose of impeller with vice-grip pliers and rotate impeller counterclockwise to unthread from shaft. |     |  |
| MPU |  |     |  |
| Ped | 4. Use a pointed tool to remove seal seat from rear of impeller.   |     |  |

**DIMENSIONAL DRAWING**  
INCHES (millimetres)

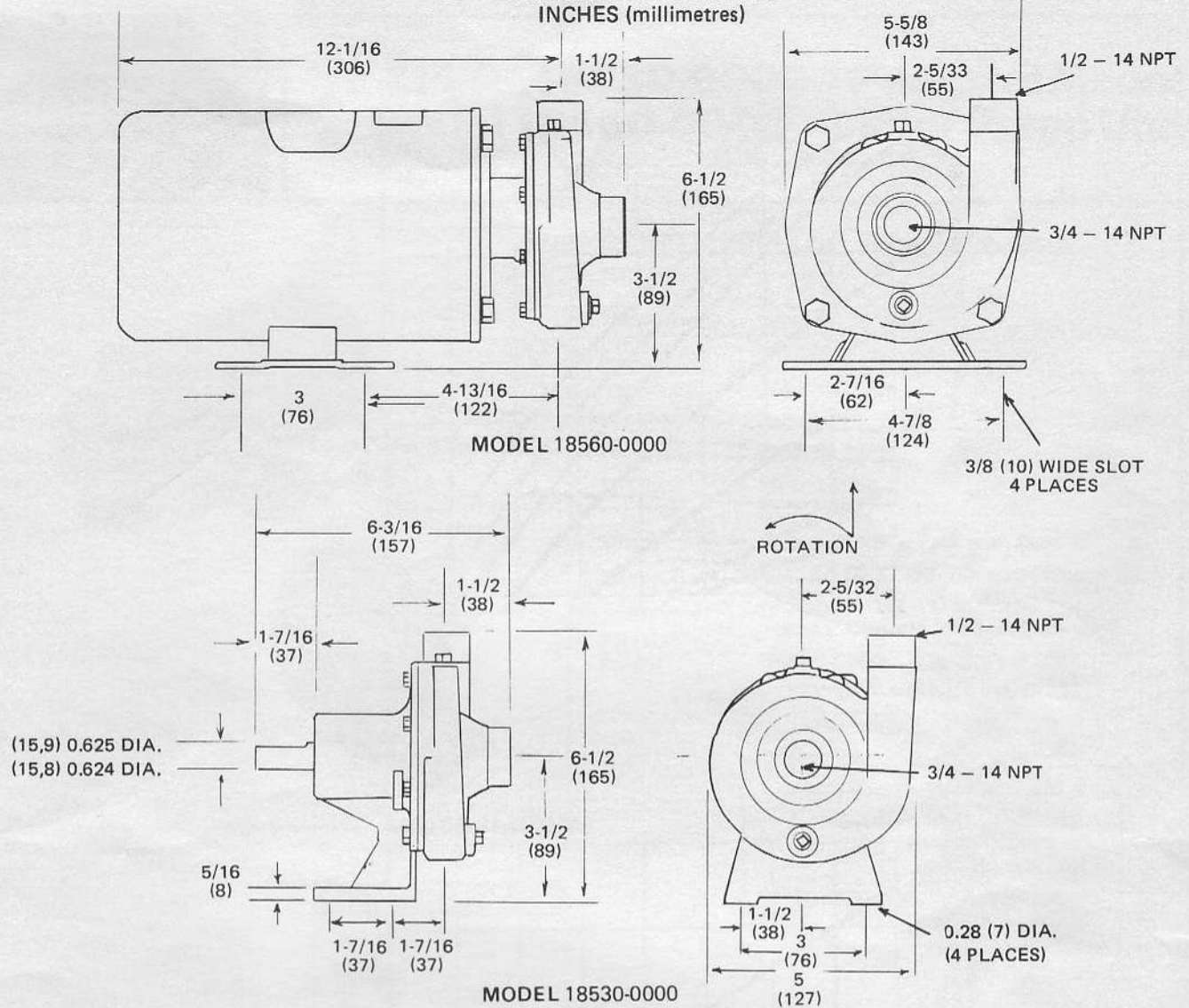

**ASSEMBLY INSTRUCTIONS**

- |            |  |            |  |
|------------|--|------------|--|
| Ped        | 1. Support inner race of ball bearing, lubricate shaft with light film of oil, press drive end of shaft through bearing firmly against shoulder. (Care should be taken not to damage threads on shaft when pressing on threaded end.)  | Ped<br>MPU | 5. Install ceramic seat into seat cup with polished surface outwards. Lubricate seat cup with water and press into impeller bore with polished ceramic surface facing out. Do not scratch or mar seat surface. |
|            | Support inner race of second ball bearing and press threaded end of shaft through bearing firmly against shoulder.   | MPU        | 6. Attach seal housing to motor with 4 bolts.  |
| Ped        | 2. Support flange side of bearing pedestal, insert threaded end of shaft/bearing assembly into pedestal. Seat inner bearing firmly against inner bearing shoulder. Install retaining ring into groove in pedestal against outer bearing.                                     | MPU<br>Ped | 7. Apply Loctite*** to shaft threads and install impeller onto shaft until it bottoms firmly against shaft shoulder. Motor pump unit normally requires one shim between impeller and shaft shoulder.           |
| Ped<br>MPU | 3. Install slinger on shaft within 1/4" of bearing or motor.   | Ped<br>MPU | 8. Install gasket against mounting flange and secure volute body to flange face with 8 screws.   |
| Ped<br>MPU | 4. Apply light coat of sealant on O.D. of seal. With large flange face of pedestal and multi-hole flange of seal housing up, install seal, carbon face outwards, using 1-5/8" O.D. x 1-3/8" I.D. tubing 1" long to press against flange of seal. Seat firmly into seal bore. | Ped<br>MPU | 9. Make sure priming plug and drain plug are secure and sealed in volute body.   |
|            |  | Ped<br>MPU | 10. Rotate shaft to make sure there is no metal contact between body and impeller.   |

Loctite PST\*\*\* is a trademark of Loctite Corporation.

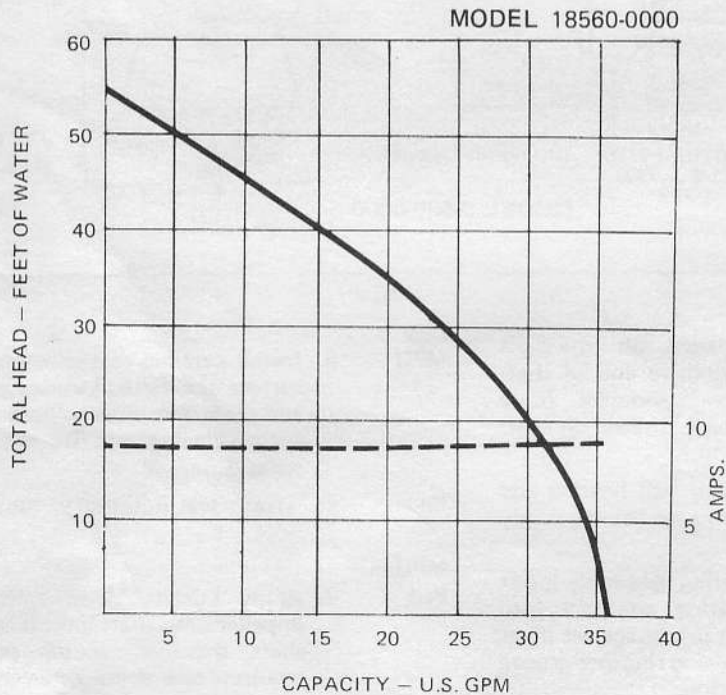
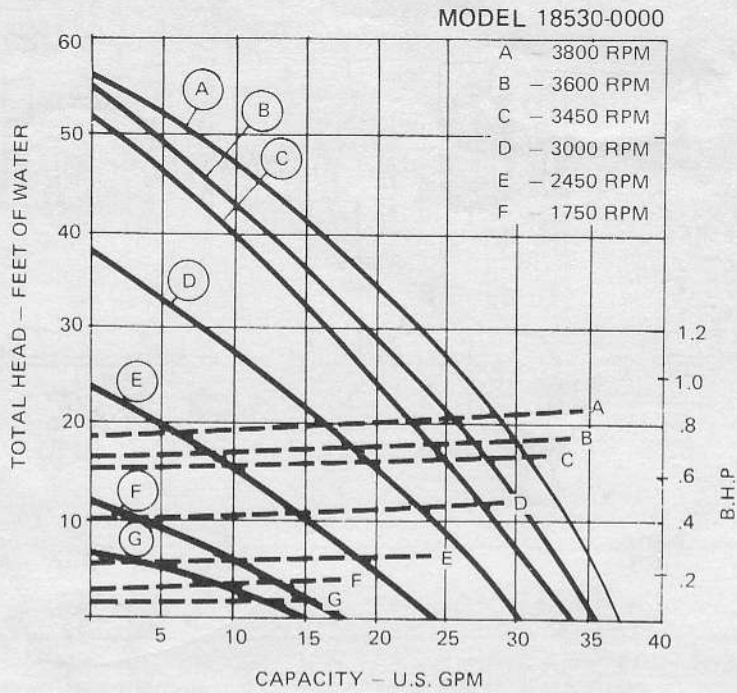

THE PRODUCTS DESCRIBED HEREIN ARE SUBJECT TO THE JABSCO ONE YEAR LIMITED WARRANTY, WHICH IS AVAILABLE FOR YOUR INSPECTION UPON REQUEST.

**ITT Jabsco**  
 ITT Fluid Technology Corporation  
 1485 Dale Way, P.O. Box 2158  
 Costa Mesa, CA 92628-2158  
 Telephone: (714) 545-8251