



Model 18510-0010

Model 18510-0010

COMMERCIAL DUTY "CENTRI PUPPY"

Bronze Centrifugal DC Motor/Pump Unit

FEATURES

- Body & Impeller** Bronze
- Seal** Carbon/Ceramic with Buna N
- Port Size** 3/4" NPT Internal
- Motor** 12 Volt DC Permanent Magnet, Fully Enclosed, Ignition Protected
- Shaft** Stainless Steel
- Weight** 8 lb, (3,6 kg) approx.



Motor meets USCG Electrical Standards (Title 33, Chapter I, Part 183; Subpart I) for IGNITION PROTECTION on gasoline powered vessels.

⚠ WARNING 	Explosion hazard. Do not pump gasoline, solvents, thinners or other flammable liquids. To do so can cause an explosion resulting in injury or death.
---	---

⚠ WARNING 	Explosion hazard. Do not operate with rivets removed from motor case. Explosion resulting in personal injury, death or property damage can occur. Case openings must be sealed to avoid explosion and maintain ignition protected rating.
---	--

APPLICATION

Suited for many general pumping applications where a flooded intake condition exists. This pump is NOT SELF-PRIMING. Typical uses include diesel fuel transfer (NOT GASOLINE), feed pump for spraying systems, irrigation, cooling systems for dairy, watering stock, washdowns, vehicle heating systems, machinery cooling systems and cutting saw blade cooling.

PERFORMANCE (Nominal 12 Vdc System)

AMPS	*FUSE/ BREAKER	PSI	FEET OF WATER	GPM
21	25	open	open	25
18	25	4.3	10	20
17	25	5.2	12	18
16	25	6.0	14	15
13	25	6.9	16	13
3	25	9.0	18	Shut-off

INSTALLATION

The pump must be mounted in a dry location -the motor is not waterproof and must not be submerged. The unit can be mounted in any desired position. It is best mounted so that water dripping from loose port connection will not wet the motor. The pump head may be mounted at 90 degree increments on the motor to allow mounting as needed.

* Customer supplied, not included with pump.

⚠ WARNING

Explosion hazard. If pump is operated in an area containing flammable vapors, wire leads must be joined by insulated mechanical locking connectors. Loose or inadequate wire connections can spark resulting in an explosion. Property damage, injury or death can occur.

ELECTRICAL CONNECTIONS

Connect black wire to negative (-) terminal of battery. The orange wire should run to a properly sized (see electrical specification) overload protected switch or circuit breaker, with a wire from switch or breaker to a positive (+) terminal of battery. Electrical circuit must be independent of all other accessories. To prolong motor life, install pump so normal motor rotation is clockwise. Use proper wire size as determined by wire table elsewhere on this sheet.

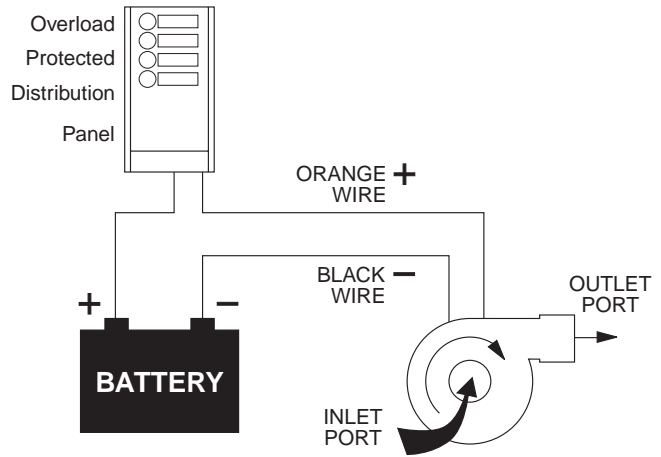
WIRING DIAGRAM**PLUMBING CONNECTIONS**

The intake and outlet ports have internal 3/4" pipe threads. Brass or plastic pipe fittings may be used to suit the installation. Plastic fittings that may be subject to cracking due to vibration should not be used below the the waterline. PTFE pipe joint tape or compound should be used if brass fittings are installed in pump. Hose maybe used with common pipe adapter installed in the pump ports.

WIRE SIZE TABLE

CONNECTION LENGTH BETWEEN BATTERY AND MOTOR	12V	24V
	1-10 ft. (3m)	#12
11-20 ft. (6m)	#10	#16
21-30 ft. (9m)	8	#12

OPERATION

The pump may be run dry for short periods of time. Running without liquid allows heat to build up between seal and shaft, thus shortening seal life. The pump can run against a closed outlet such as encountered when using a garden hose type shut-off nozzle. Small particles of trash and debris will pass through the pump, though an intake strainer should be fitted if excessive problems are encountered with pump clogging.

⚠ WARNING

Motor runs hot; about 180° is normal temperature. Prolonged contact during operation can cause a burn.

EXPLODED VIEW

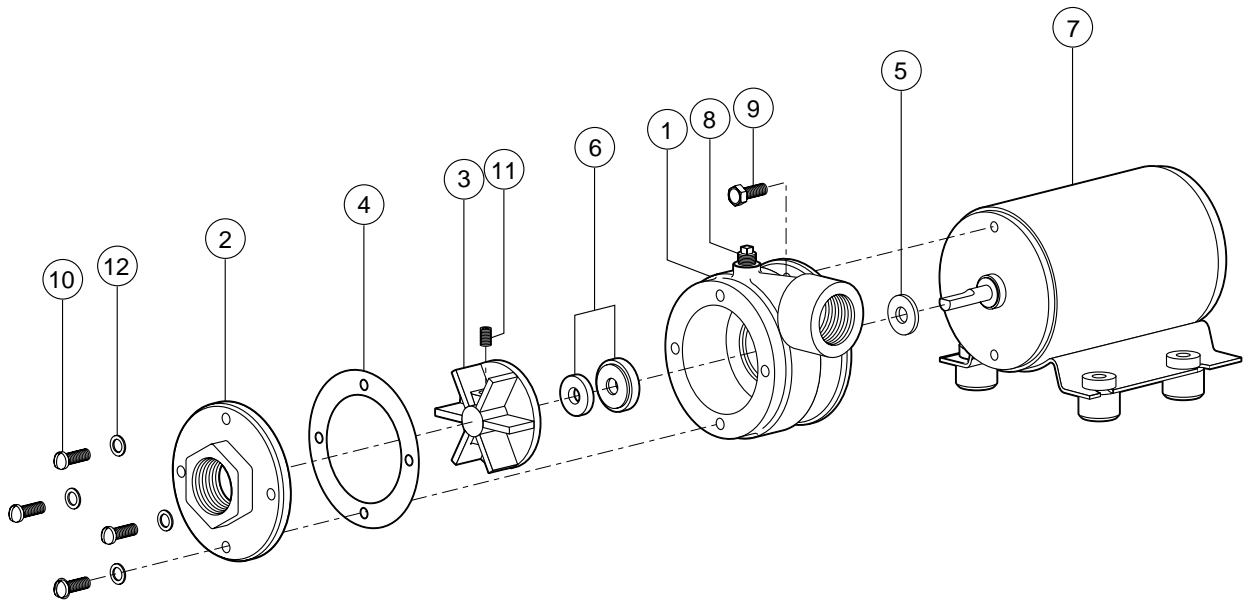

PARTS LIST

Key	Part Number	Description	Qty.
1	18527-0000	Pump Body	1
2	18514-0000	End Cover	1
3	18526-0000	Impeller	1
4	18516-0000	Gasket	1
5	6342-0000	Slinger	1
6	96080-0552	Seal, Mechanical	1
7*	18753-0461	Motor 12 Volt DC	1
8	92650-0040	Plug	1
9	98019-0020	Body Mounting Screw	2
10	91027-0013	End cover Screw	4
11	91083-0040	Impeller Set Screw	1
12	91602-0020	Lock Washer #10 S.S.	4

*Includes motor base

SERVICE INSTRUCTIONS

NOTE: The seal consists of two parts. The half with the metal case and carbon face go into the pump body. The other half of the seal is a ceramic disk with a rubber boot and is installed into the back face of the impeller.

Disassembly

1. Remove end cover screws, end cover and gasket.
2. Remove pipe plug in top of body and rotate impeller so the set screw aligns with the plug hole. Insert a 1/8" allen wrench through the plug hole and loosen impeller setscrew. Remove the impeller.
3. Remove screws securing the body to the motor and remove the body.

4. Remove the old ceramic half of the seal with a screwdriver or hooked wire.
5. From the motor side of the body press the metal case seal half out of the body into the impeller bore. Clean the seal bore.

Assembly

1. For the best results, apply a thin coat of pipe thread sealant to the seal bore in the body before installing new seal. Install the the seal from inside the body using a hollow tube 1 1/4" OD by 1 1/8" ID. With the tube against the flange of the seal press or tap gently on the tube until the flange of the seal is seated all the way around on the ledge in the body. Lubricate the rubber boot with a small amount of soapy water. To protect the seal surface put a clean piece of paper on the ceramic face and push the seal by hand into the impeller bore until it is completely seated. Be sure that both the carbon and the ceramic faces are clean of grease and fingerprints.
2. Install the body to the motor. Position the motor with the pump body up and the back of the motor down to correctly position the shaft end play.
3. Slide the impeller on the shaft with the set screw facing the plug hole in the body. Press the impeller down compressing a spring in the seal until the impeller bottoms out against the body. Tighten the set screw in the impeller before releasing pressure against the impeller. This sets the proper seal face clearance.
4. Install the pipe plug into the body.
5. Ensure the body and end cover surfaces are clean where they contact the gasket. Align the end cover and new gasket with the body and secure it with the end cover screws.

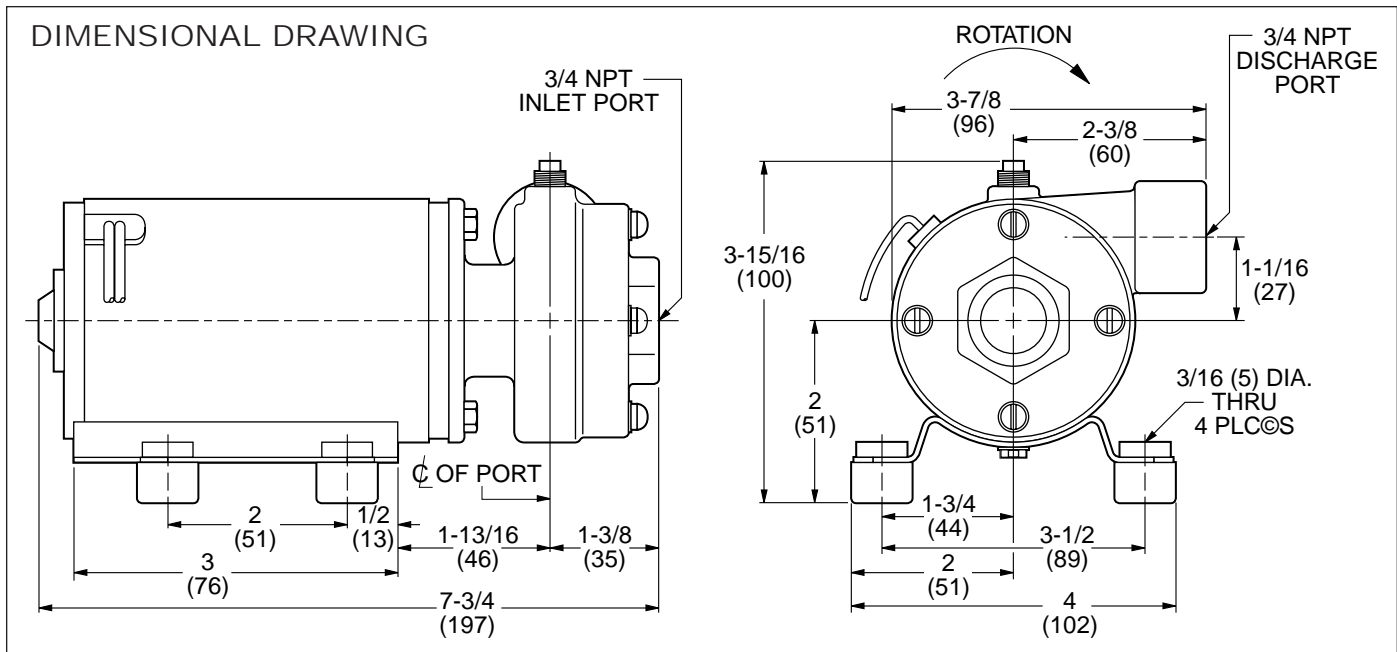

ONE YEAR LIMITED WARRANTY

A. LIMITED WARRANTY:

ITT warrants that at the time of shipment, the products manufactured by ITT and sold hereunder shall be in conformity with applicable written specifications and descriptions referred to of set forth herein free from defects in material and workmanship, merchantable, and suitable for a particular purpose, provided such is implied by State law under the circumstances of this sale.

B. WARRANTY ADJUSTMENT:

1. ITT agrees to repair or furnish a replacement for, but not to remove or install, any product or component thereof which, within one (1) year from date of purchase, shall upon test and examination by ITT prove defective within the above warranty. Receipt verifying purchase date is required to obtain adjustment.
2. Buyer shall notify ITT of any defect within this warranty no later than ninety (90) days after the defect is discovered.
3. No product will be accepted for return or replacement without the prior written authorization of ITT. Upon such authorization, and in accordance with instructions from ITT, the product will be returned to ITT, shipping charges prepaid by Buyer. Products returned to ITT will be addressed as follows:

ITT JABSCO

20 Icon

Foothill Ranch, CA 92610-3000

Or to such alternate locations as may be designated on the product, its container, or this sheet.

Repair or replacement made under this warranty will be shipped prepaid to Buyer.

Jabsco



ITT Industries

Engineered for life

U.S.A.
Jabsco
20 Icon
Foothill Ranch, CA 92610-3000
Tel: 949.609.5106
Fax: 949.859.1254

UNITED KINGDOM
Jabsco
Bingley Road, Hoddesdon
Hertfordshire EN11 OBU
Tel: +44 (0) 1992 450145
Fax: +44 (0) 1992 467132

CANADA
Fluid Products Canada
55 Royal Road
Guelph, Ontario N1H 1T1
Tel: (519) 821.1900
Fax: (519) 821.2569

JAPAN
NHK Jabsco Company Ltd.
3-21-10, Shin-Yokohama
Kohoku-Ku, Yokohama, 222
Tel: 045.475.8906
Fax: 045.475.8908

GERMANY
Jabsco GmbH
Oststrasse 28
22840 Norderstedt
Tel: +49-40-53 53 73 -0
Fax: +49-40-53 53 73 -11

C. EXCLUSIONS FROM WARRANTY AND LIMITATION OF LIABILITY:

1. The foregoing warranty is limited solely as set forth herein and applies only for the period designated above.
2. ITT SHALL NOT BE LIABLE FOR ANY LOSS, DAMAGE, SPECIAL OR CONSEQUENTIAL DAMAGE OF ANY KIND, WHETHER BASED UPON WARRANTY, CONTRACT, NEGLIGENCE, OR STRICT LIABILITY ARISING IN CONNECTION WITH THE SALE, USE, OR REPAIR OF THE PRODUCT.
3. THE MAXIMUM LIABILITY OF ITT IN CONNECTION WITH THIS WARRANTY SHALL NOT IN ANY CASE EXCEED THE CONTRACT PRICE FOR THE PRODUCT CLAIMED TO BE DEFECTIVE OR UNSUITABLE.
4. This warranty does not extend to any product manufactured by ITT which has been subjected to misuse, neglect, accident, improper installation, or use in violation of instructions furnished by ITT.
5. This warranty does not extend to or apply to any unit which has been repaired or stored at any place other than ITT's factory, or by persons not expressly approved by ITT, not to any unit the serial number, model number, or identification of which has been removed, defaced or changed.
6. Components manufactured by any supplier other than ITT shall bear only that warranty made by the manufacturer of that product.
7. This warranty applies to products defined as "consumer products" by the Consumer Product Warranties Act as from time to time amended.

D. CONSUMER RIGHTS: This warranty gives you specific legal rights, and you may have other rights which vary from state to state. Some states do not allow exclusion or limitation of damages.

STANDARD WARRANTY: if the products manufactured and said hereunder are not Consumer Products, the warranty extended to Buyer shall be as set forth in subparagraphs (A), (B), and (C), **EXCEPT THAT ALL EXPRESS OR IMPLIED WARRANTIES OR MERCHANTABILITY OR SUITABILITY FOR ANY PARTICULAR PURPOSE ARE EXCLUDED.**