

JABSCO® PUMPS

Self-Priming Pumps

MODEL 18320-Series 18330-Series

Electro-Magnetic Clutch Units

PRODUCT DATA

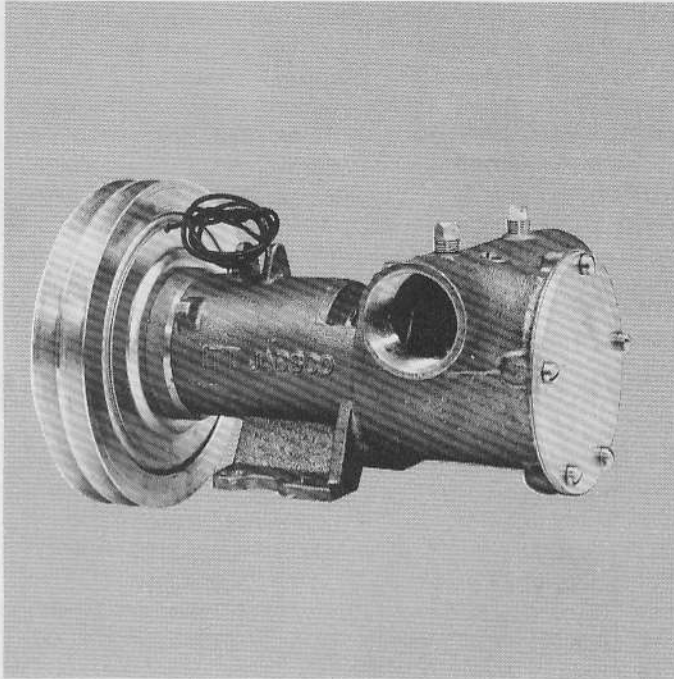

DESIGN FEATURES

Body:	Bronze
Impeller:	Jabsco Neoprene Compound
Shaft:	Brass
Ports:	Model 18320 1½" IPT Model 18330 2" IPT
Seal:	Carbon-Ceramic Face Type
Bearings:	Sealed Ball Bearings
Shipping Weight:	18320 - 28 Lbs. (12,7 Kg) 18330 - 29 Lbs. (13,2 Kg)

STANDARD MODELS

Model	Voltage	Port Size
18320-0000	12 VDC	1½" IPT
18320-0001	24 VDC	1½" IPT
18320-0002	32 VDC	1½" IPT
18330-0000	12 VDC	2" IPT
18330-0001	24 VDC	2" IPT
18330-0002	32 VDC	2" IPT

APPLICATIONS

MARINE: Engine cooling, Pumping bilges, Washdowns, Circulating water in bait tanks. Utility dock side pump.

INDUSTRIAL: Circulating and transferring, Velocity-mixing, Return spill, Sump drainage, Chemicals, Pharmaceuticals, Soap, Liquors, Ink, Dyes, Alcohol, Tanning Liquors, Glycerine, Brine, etc.

FARMING: Pumping water for stock, Pumping water from shallow wells and cisterns.

PUBLIC UTILITIES AND MUNICIPALITIES: Under the hood mounting on service trucks for dewatering and draining meter boxes, manholes, excavations, and truck installation under hood for emergency pumping.

INSTALLATION

Pump may be mounted in any position. Intake and discharge ports are determined by the direction of shaft rotation (refer to dimensional drawing). Before installing, energize clutch and turn pump shaft in direction of shaft rotation. Drive pump with two "A" size belts. Avoid dry-running by using Vacuum Switch Model 4732-0000 for automatic shut-off.

NOTE: MODEL 18330-SERIES IS INTERCHANGEABLE WITH EARLIER PUMP MODEL 10680-SERIES: BASE MOUNTING DIMENSIONS, HEIGHT ABOVE BASE TO SHAFT, AND HEIGHT ABOVE BASE TO PORT CENTER-LINE ARE THE SAME.

WIRING

Connect wires as shown for manual on-off operation. For remote control or automatic shutoff operation, see data sheet on Model 4732-0000 Vacuum Switch Kit (Form 43000-0024). For complete wiring instructions see diagram on page 3.

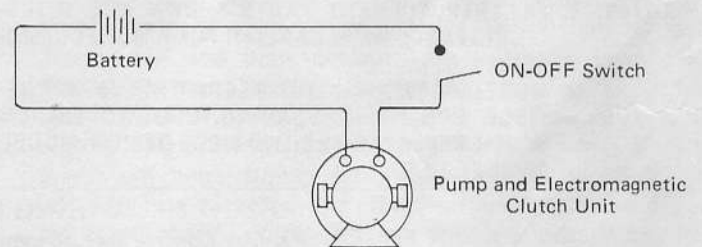

OPERATION

Pump will self-prime at low or high speeds. Make sure that all connections are airtight. **DO NOT RUN PUMP DRY FOR MORE THAN 30 SECONDS. LACK OF WATER FLOW MAY DAMAGE IMPELLER.** To drain pump, loosen end cover screws. See Head Capacity Table for head pressures and flow. To avoid costly shutdowns, keep a Jabsco Service Kit on hand.

JABSCO PRODUCTS **ITT**

EXPLODED VIEW

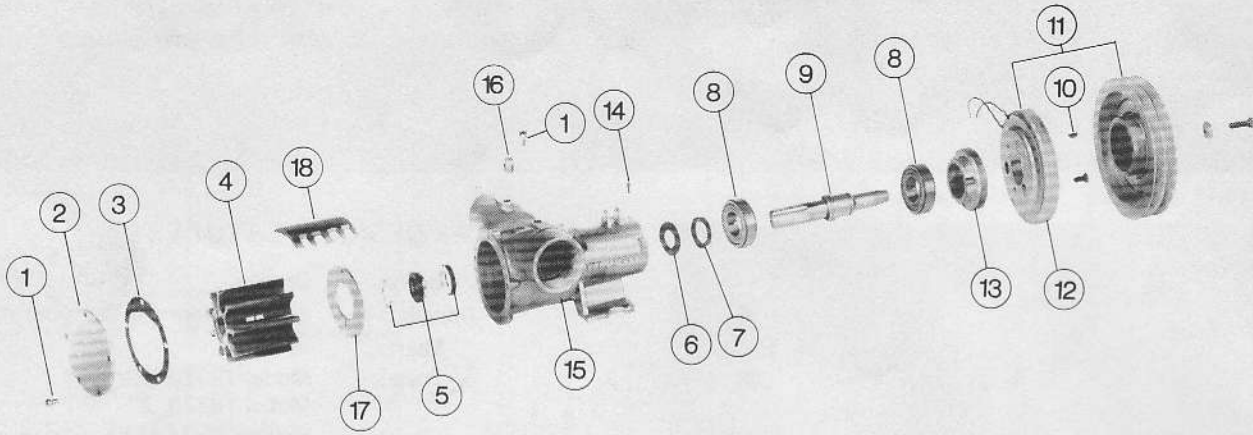

PARTS LIST

Key	Description	Part Number	Qty.
1	Screw (End Cover and Cam)	91005-0040	6
2	End Cover		1
	Model 18320-0000	18294-0004	
	18320-0001	18294-0005	
	18320-0002	18294-0006	
	18330-0000	18294-0007	
	18330-0001	18294-0008	
	18330-0002	18294-0009	
3	*Gasket	816-0000	1
4	*Impeller	6760-0001	1
5	*Seal Assembly (Shaft)	6408-0000	1
6	Slinger	3181-0000	1
7	Bearing Seal	92701-0180	1
8	Ball Bearing	92600-0260	2
9	Shaft	10677-0010	1
10	Drive Key	91401-0100	1

Key	Description	Part Number	Qty.
11	Clutch Assembly		1
	12 VDC	92300-0030	
	24 VDC	92300-0061	
	32 VDC	92300-0050	
12	Field Coil		1
	12 VDC	98022-0500	
	24 VDC	98022-2155	
	32 VDC	98022-0510	
13	Clutch Adaptor	10793-0000	1
14	Roll Pin	93100-0160	2
15	Body		1
	Model 18320-Series (1½" IPT)	18313-0003	
	18330-Series (2" IPT)	18313-0000	
16	Pipe Plug	92650-0070	2
17	Wearplate	2574-0000	1
18	Cam	6988-0000	1
	Service Kit	90254-0001	

* Parts contained in Service Kit

- NOTES:** 1. ALL REPLACEMENT PARTS SHOWN ARE INTERCHANGEABLE WITH EARLIER PUMP MODEL 10680-SERIES.
2. MODELS 18320 and 18330-SERIES HAVE A ONE-PIECE BODY AND BEARING HOUSING DESIGN WHICH REPLACES THE TWO-PIECE DESIGN, MODEL 10680-SERIES.

WIRING DIAGRAM

Remote Control and Automatic Engine Driven Bilge Pump

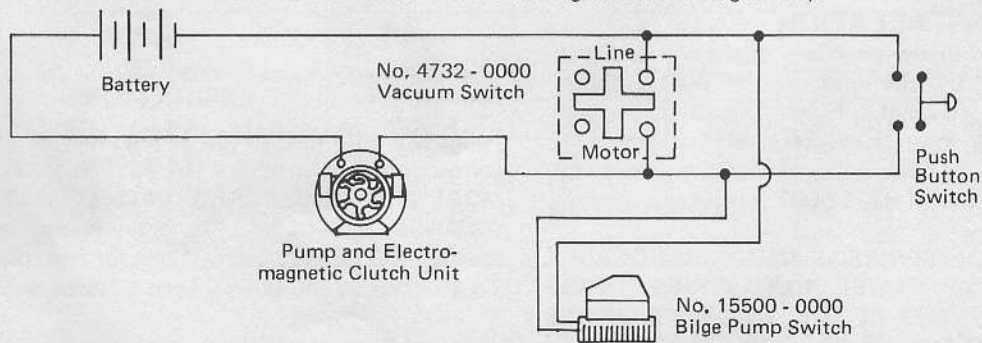

REMOTE CONTROL (When Engine Is Running): Install a pushbutton switch at one or more locations. Depress pushbutton for 2 seconds. If there is water in bilge, pump will operate until dry at which time vacuum switch will stop pump. If no water is in bilge, pump will stop when pushbutton is released.

AUTOMATIC BILGE PUMP (When Engine Is Running): Install No. 15500-0000 Automatic Bilge Pump Switch where it will energize clutch at maximum high water level in bilge. When water raises switch float, pump will start. Vacuum switch will maintain closed circuit until bilge is pumped dry. Pump will automatically stop, preventing impeller damage.

SERVICE INSTRUCTIONS

Impeller Replacement: Remove end cover and gasket. Pull impeller out by grasping hub with pliers. With a rotary motion in the direction the pump will be turning, push impeller into the impeller bore. A light coating of grease in the impeller bore will protect impeller during initial dry start up. Install gasket and end cover.

Shaft Seal Replacement: Remove end cover, gasket and impeller as outlined above. Loosen cam screw several times. Give cam screw a couple of sharp raps with the handle of the screw driver to loosen the cam from the impeller bore. Remove the cam screw and cam (clean permatex from cam and impeller bore). Remove wearplate with hooked wire. Remove marcel washer, seal assembly and seal seat assembly from seal bore with hooked wire, taking care not to scratch shaft or seal seat bore. Clean shaft surfaces behind splines and inspect for scratches or wear. Replace if necessary. Before installing new seal parts, clean any oil or grease from carbon and ceramic seal faces. Dip seal seat and gasket assembly in water and press into seal bore with boot first. Dip carbon seal assembly in water and install over shaft, carbon toward ceramic seal seat, until it bottoms firmly against ceramic seat. Slide marcel spring washer over shaft and against the rubber boot (washer) on carbon seal assembly. Replace wearplate, aligning notch with dowel pin in body. Permatex top surface of cam and cam screw threads, and install cam in impeller bore. Snug up but do not tighten cam screw. Replace impeller gasket and end cover as outlined above. Tighten end cover screws. Tighten cam screw.

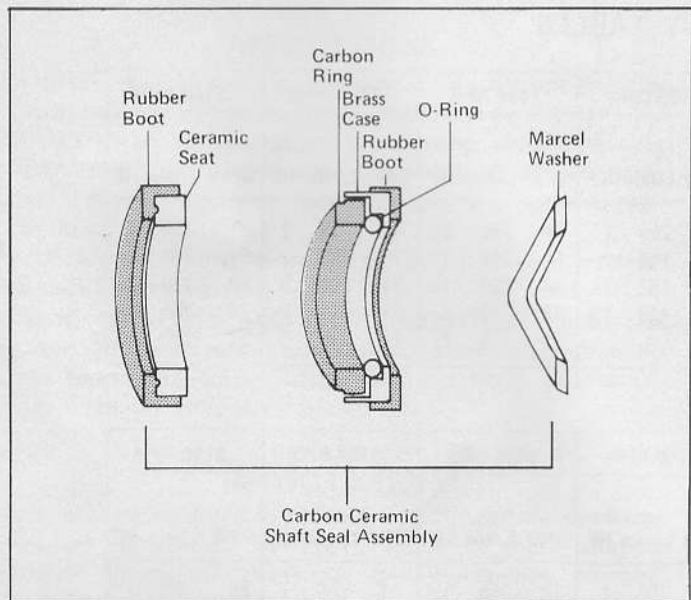

Field Coil Replacement: Remove drive belts from pulley. Disconnect wiring. Remove center bolt and washer (it may be necessary to remove end cover to hold impeller from turning while removing center bolt). Tap pulley with soft mallet to remove from shaft taper. Remove three bolts and washers holding field coil to adaptor. Remove and replace field coil, tightening the three bolts securely. With drive key in place in shaft, replace pulley assembly. Secure to shaft with center bolt and washer (again it may be necessary to hold the impeller from turning to tighten center bolt). Replace drive belts. Do not overtighten belts. A deflection of $\frac{1}{2}$ " midway between pulley is generally considered normal. Reconnect wiring.

Major Repair: Remove pump from installation.

Disassembly: Remove end cover gasket impeller cam and seal assembly as outlined in "shaft seal replacement". Remove clutch pulley and field coil as outlined in "field coil replacement". Use a punch to drive roll pins (key 14) in towards shaft, approximately $\frac{3}{8}$ " (10mm). Remove clutch adaptor from body punch roll pins out of adaptor. Press on impeller end of shaft to remove shaft and bearing assembly from body bearing bore. Slinger will slide off shaft and may be removed through drain slot in body. Use screwdriver to pry inner bearing seal from body. Take care not to scratch or damage body bore. If ball bearings are worn or any slight roughness is felt when the bearing is turned, replace both bearings. Support inner race of bearing and press on impeller end of shaft to remove inner bearing. Replace all worn or damaged parts.

Assembly: Support inner race of ball bearing. Insert impeller drive end of well oiled shaft to seat inner bearing firmly against shaft shoulder. Reverse shaft and insert tapered end of shaft through bearing supported on inner race. Press on impeller end of shaft to seat second bearing firmly against shaft shoulder. Wipe shaft free of oil. Lightly grease inner bearing seal and press into body bearing bore seating firmly against shoulder in bearing seal bore with lip facing towards impeller bore. Slide slinger into drain slot of body and position so that shaft can be inserted through it. Support impeller end of body, insert impeller end of shaft through bearing seal and press on outer race of outer bearing to position shaft and bearing assembly into bearing bore, firmly against shoulder. Install clutch adaptor into bearing bore. If reusing adaptor previously disassembled from pump, line up dowel pin holes during assembly of adaptor to body. If installing new adaptor (which does not have predrilled dowel pin holes) install into bearing bore until it is bottomed firmly and use dowel pin holes in body to pilot drill dowel pin holes through adaptor, two places. 180° apart. Clean any brass chips from bearing area. Press roll pins into body to secure adaptor. Attach field coil to adaptor with three bolts and washers. Before assembling clutch pulley, turn body over and install seal assembly, wearplate cam and impeller as described in shaft seal and impeller replacement instructions. Turn body over to assemble clutch pulley as outlined in field coil replacement instructions. Complete assembly by installing gasket and end cover.

DIMENSIONAL DRAWING

Dimension	Model 18320-Series	Model 18330-Series
A	7" (178mm)	8" (203mm)
B	3 1/2" (89mm)	4" (102mm)
C	3 3/16" (97mm)	4 1/8" (105mm)
D	1 5/16" (33mm)	1 5/8" (41mm)
E	1 1/2" IPT	2" IPT

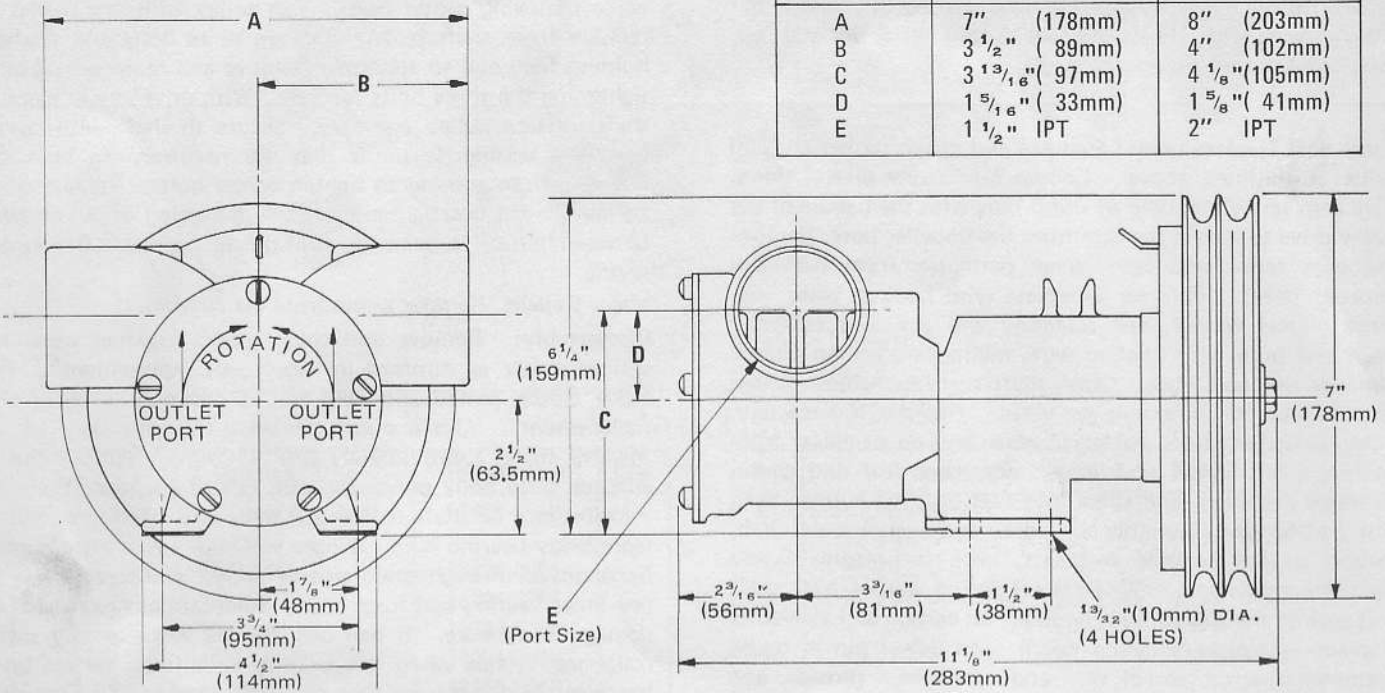

HEAD CAPACITY TABLES

MODEL 18330-0000 2" PORTS

TOTAL HEAD				500 RPM			870 RPM			1160 RPM			1450 RPM			1750 RPM			2100 RPM		
Lbs Per Sq Inch	Kg Per Sq cm	Feet of Water	Meters of Water	GPM	L/min	HP	GPM	L/min	HP	GPM	L/min	HP	GPM	L/min	HP	GPM	L/min	HP	GPM	L/min	HP
4.3	.3	10	3.0	23	87	1/2	40	151	1	54	204	1	70	265	1 1/2	83	314	2	95	360	3
8.7	.6	20	6.1	22	83	1/2	37	140	1	50	189	1	66	250	1 1/2	79	299	2	91	344	3
17.3	1.2	40	12.2	17	64	1/2	30	114	1	43	163	1 1/2	58	220	1 1/2	71	269	3	82	310	3
26.0	1.8	60	18.3	-	-	-	22	83	1 1/2	34	129	1 1/2	48	182	2	61	231	3	70	265	5
30.3	2.1	70	21.3	-	-	-	-	-	-	-	-	-	41	155	2	55	208	3	62	235	5

MODEL 18320-0000 1 1/2" PORTS

TOTAL HEAD				500 RPM			870 RPM			1160 RPM			1450 RPM			1750 RPM			2100 RPM		
Lbs Per Sq Inch	Kg Per Sq cm	Feet of Water	Meters of Water	GPM	L/min	HP	GPM	L/min	HP	GPM	L/min	HP	GPM	L/min	HP	GPM	L/min	HP	GPM	L/min	HP
4.3	.3	10	3.0	23	87	1/2	40	151	1	54	204	1	70	265	1 1/2	83	314	2	95	360	3
8.7	.6	20	6.1	22	83	1/2	37	140	1	50	189	1	66	250	1 1/2	79	299	2	91	344	3
17.3	1.2	40	12.2	17	64	1/2	30	114	1	43	163	1 1/2	58	220	1 1/2	71	269	3	82	310	3
26.0	1.8	60	18.3	-	-	-	22	83	1 1/2	34	129	1 1/2	48	182	2	61	231	3	70	265	5
30.3	2.1	70	21.3	-	-	-	-	-	-	-	-	-	41	155	2	55	208	3	62	235	5

JABSCO PRODUCTS **ITT**

Marine and Recreation Components Division
International Telephone and Telegraph Corporation
1485 Dale Way, Costa Mesa, California 92626

Telephone: (714) 545-8251