

# JABSCO® PRODUCTS

Seal-less Magnetic Drive Centrifugal Pumps

# MODEL 18230-Series

Motor Pump Units

## PRODUCT DATA

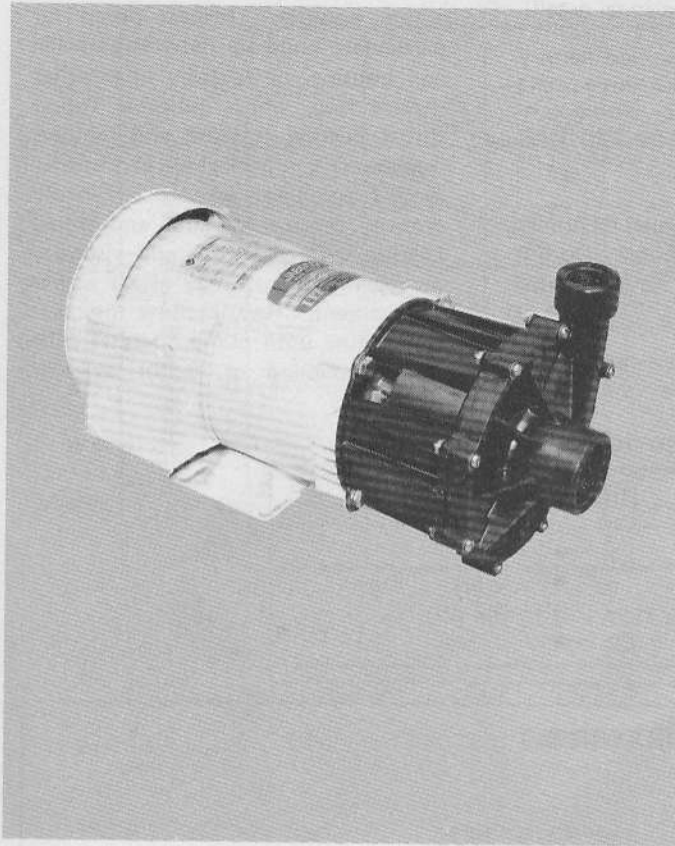

### DESIGN FEATURES

#### CORROSION RESISTANT

**Pump Material:** Glass Filled Epoxy Plastic Suitable for Temperatures to 200° F. (93° C)

**Impeller Design:** Enclosed 4.35" Dia. — 1 HP  
4.0 Dia. — ¾ HP  
3.5 Dia. — ½ HP

#### SEAL-LESS

**Magnetic Drive:** Magnets enclosed in a molded epoxy cup. No Contact With Liquid Being Pumped

**Ports:** Suction 1½" NPT Internal  
Discharge 1" NPT Internal

**Motors:** Open Drip Proof or T.E.F.C.  
NEMA "C" Face, 115/208/  
230 VAC

Single Phase, 60 Cycle, 3450 RPM  
Ball Bearing, Class B Insulation  
Thermal Overload Protected. Wired  
for 115 VAC and Supplied With 6  
foot Cord With 3 Prong Plug.

**Weight:**

1 HP	Open	32.5 lbs. (14.7 Kgs)
	TEFC	34.5 lbs. (15.6 Kgs)
¾ HP	Open	32.5 lbs. (14.7 Kgs)
	TEFC	34.5 lbs. (15.6 Kgs)
½ HP	Open	29.5 lbs. (13.4 Kgs)
	TEFC	31.5 lbs. (14.3 Kgs)

MODEL 18230-SERIES

### STANDARD MODELS

Impeller Size	Motor HP	MOTOR TYPE	
		OPEN	TEFC
4.35	1	18230-0000	18230-0001
4.00	¾	18230-0002	18230-0003
3.50	½	18230-0004	18230-0005

### APPLICATIONS

Seal-less magnetic drive motor pump units are designed to handle corrosive liquids without concern of selection of exotic mechanical shaft seal materials or leakage of expensive or dangerous fluids between shaft and housing.

Highly corrosive chemicals or caustic solutions compatible with glass filled epoxy plastic may be transferred or circulated. All parts in contact with fluid are glass filled epoxy plastic or graphite filled teflon.

Chemicals such as Alcohols, Benzene, Hexane, Chlorinated hydrocarbons, Ether compounds, Fatty acids, Hydrochloric acid, Phosphoric acid, Hydrofluoric acid, Tannic acid, Carbolic

acid, Sodium hydroxide, Sodium nitrate, Potassium hydroxide, Ammonium hydroxide, Toluene, Trichloroethylene, Laquers, etc... may be handled. For a more complete list of liquids compatible with epoxy plastic, consult the Jabsco Chemical Resistance Table or the factory.

### INDUSTRIAL AND OEM

Transfer, circulation or filtration of photo chemicals, etching solutions, plating baths, laboratory systems, processing, transfer and application of agricultural chemicals, fume scrubbing, circulation, and exotic metal recovery processes are typical applications.

### INSTALLATION

**LOCATION** — Pumps with TEFC motors may be mounted in any position. Pumps with open drip-proof motors should be suitably mounted to prevent moisture from entering motor. Volute may be removed and rotated to any one of eight different port positions to simplify piping. If the pump is to be mounted above the liquid level, provisions must be made to assure that the suction line and, pump cavity is flooded before starting pump.

**JABSCO PRODUCTS** **ITT**

## INSTALLATION (Cont'd)

**THIS PUMP WILL NOT SELF PRIME!**  
To prevent cavitation and obtain maximum service life, it is important that suction line is free of restrictions and sharp bends. Factory application engineering assistance is available.

**NOTE:** For inlet pressure over 20 PSI, consult the factory for assistance.

**PLUMBING** — All piping to the pump must be supported independently of the pump. **CAUTION:** Use only plastic fittings in the suction and discharge ports. Keep suction and discharge lines as free of elbows and bends as possible. To assure optimum performance, suction port line should be straight for a minimum length of 12" without elbow or reducers.

Suction line must be air tight to maintain prime. A flap type foot valve at the suction intake or a check valve in the discharge line may be installed to retain liquid in system during shut-down. An auxiliary prime line may be installed by drilling and tapping boss on volute face (see dimensional detail).

**WIRING** — Pump motors are factory wired with a 115 VAC three-prong plug. Consult the motor wiring connection diagram below for 230 VAC motor connection.

**OPERATION** — Pump must be primed to begin pumping operation. Do not operate pump dry for extended periods.

If pumping action ceases during normal operation and the motor con-

tinues to run, disconnect power to the motor. Let pump motor come to a complete stop, then resume operation, this allows the magnet to "recouple".

Recurring uncoupling indicate excessive horsepower requirements or friction contact between impeller and volute housing. Inspect pump for particulate build up between impeller and housing, or scuffing of impeller shroud face, which indicates Teflon thrust bearing is worn and requires replacement. Check track on impeller shroud for wear groove. If badly grooved replace impeller and thrust bearing. Change in liquid viscosity or specific gravity may affect power requirement. Restrict flow thru discharge line until pump operates without uncoupling or motor overload kick out.

### MOTOR CONNECTIONS

LOW VOLTAGE (115V)	HIGH VOLTAGE (230V)
L1 — ●	L1 — ●
3 — ●	● — V (9)
4 — ● — V (9)	● — Blk (2)
L2 — ● — Blk (2)	L2 — ●

### DIMENSIONAL DRAWING

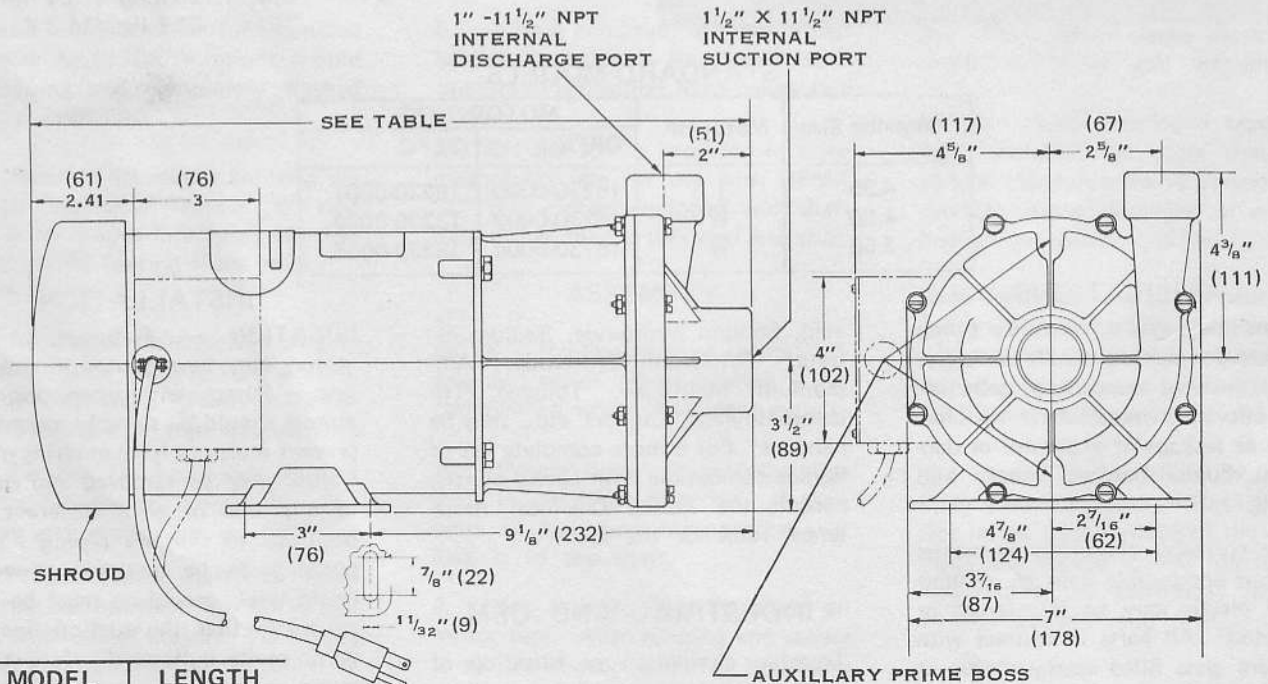

MODEL	LENGTH
18230-0000	15 3/4" (400)
18230-0001	16 3/4" (425)
18230-0002	15 3/4" (400)
18230-0003	16 3/4" (425)
18230-0004	15 3/8" (391)
18230-0005	16 3/8" (416)

(Millimeter Equivalent)

## PERFORMANCE AND SELECTION

**Fluid Temperature Range:** 32° F to 200° F  
 (0-93° C)  
**Viscosity:** To 50 centipoise  
 or 200 SSU.  
**Specific Gravity:** To 1.30

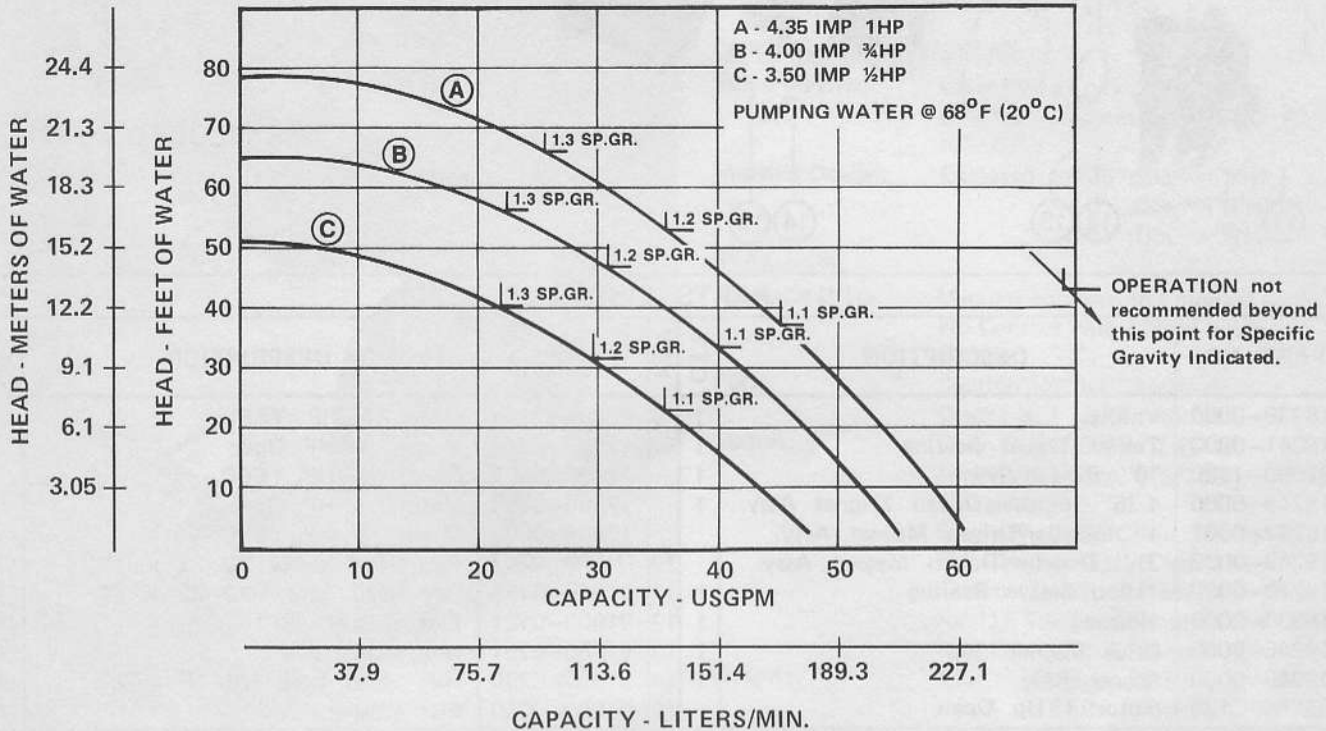

Head vs flow curves are representative of average production test data pumping water at 68° F. The operating points on the curves indicate the limits of application for pumping liquids with specific gravities greater than water. For a given specific gravity the pump should not be operated to the right of the indicated specific gravity figure or motor overload and/or magnetic drive uncoupling will result. All calculations for total operating head should be converted to feet of head of water to select the optimum operating conditions using these curves. In some cases, restric-

tion of the discharge of the pump will be necessary to keep the operating flow to the left of the particular specific gravity operating point.

**EXAMPLE:** Liquid with specific gravity of 1.10, total head calculated to be 20 feet of water. Referring to the performance curves at 20 feet head on curve A 4.35 impeller with 1 Hp motor) we are to the right of the operating point for a specific gravity of 1.10. If we choose this pump we must restrict the discharge so the pump is operating against approx-

imately 37 feet head of water giving us a capacity of 45 GPM.

At 20 feet head on curve B (4.00 impeller with ¾ Hp motor) we are to the right of the operating point for 1.10 specific gravity therefore the pump would have to operate against 33 feet head of water with a pump capacity of 40 GPM. At 20 feet head on curve C (3.50 impeller with ½ Hp motor) we are to the right of the operating point for 1.10 specific gravity, therefore we would have to restrict the discharge to 22 feet of head of water for a capacity of 36 GPM.

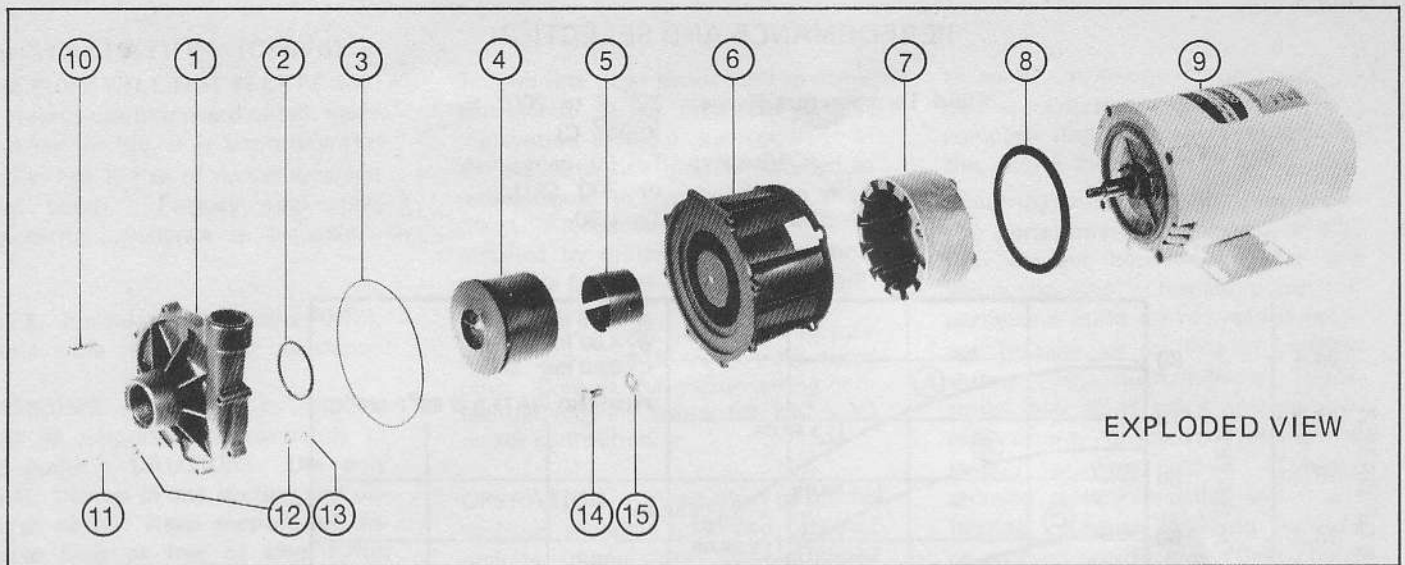

EXPLODED VIEW

PARTS LIST

KEY	PART NO.	DESCRIPTION	QTY.	KEY	PART NO.	DESCRIPTION	QTY.
1	18238-0000	Volute	1	9	93004-2140	Motor, 1 HP TEFC	1
2	18241-0000	Teflon Thrust Bearing	1		17909-0006	Motor, ¼ HP Open	
3	92000-1180	"0" Ring (Viton)	1		17909-0007	Motor, ¼ HP TEFC	
4	18243-0000	4.35" Impeller/Driven Magnet Assy.	1		17909-0008	Motor, ½ HP Open	
	18243-0001	4" Impeller/Driven Magnet Assy.			17909-0009	Motor, ½ HP TEFC	
	18243-0002	3½" Impeller/Driven Magnet Assy.		10	91045-0367	Pan Head Screw 10-32 x 1¼"	7
5	18249-0000	Teflon Sleeve Bearing	1	11	91045-0368	Pan Head Screw 10-32 x 2"	1
6	18236-0000	Housing	1	12	91602-0121	Flat Washer, #10	16
7	18246-0000	Drive Magnet Cup	1	13	91085-0261	Hex Nut, 10-32	8
8	18240-0000	Spacer Ring	1	14	91094-0230	Hex Head Bolt 3/8-16 x 7/8"	4
9	93004-2130	Motor 1 Hp Open		15	91602-0260	Flat Washer, 3/8"	4

SERVICE

DISSASSEMBLY

**Caution:** Pumps which have handled corrosive or caustic solutions should be drained and completely flushed prior to servicing.

1. Remove (8) screws securing volute to housing. Remove "0" ring from outer groove in volute. Remove Teflon thrust bearing from inner groove in volute.

2. Remove impeller/driven magnet assembly from housing with a firm, straight-away pull. Remove Teflon sleeve bearing from bore of assembly.

3. Remove (4) bolts and washers securing housing to motor. Remove housing and spacer ring.

4. Prevent motor shaft from turning (Insert screwdriver into fan or slot under shaft cap of motor). Turn Drive magnet cup in a counter clockwise direction and remove.

5. Check condition of teflon thrust bearing in volute. Replace if worn (minimum projection from volute face .031).

**NOTE:** Set screws provided in drive magnet cup are for use with NEMA "C" face motors equipped with shaft flats rather than a threaded end stub.

ASSEMBLY

**NOTE:** Replacement of volute "0" ring and teflon thrust bearing is recommended when servicing pump.

1. Rotate drive magnet cup onto shaft in clockwise direction. A firm twist of the drive magnet cup will lock it to the shaft.

2. Set spacer ring in place on motor face. Align housing and secure it to the motor with (4) bolts and washers.

3. Place Teflon sleeve bearing into recess in drive end of impeller.

**NOTE:** Sleeve bearing is taper cut. When installed the edges should be parallel otherwise the inner edges will overlap, causing jamming or uncoupling of the magnetic drive.

Slide Teflon bearing and impeller onto center of housing. Magnetic attraction will pull the impeller into place. Do not allow impeller to snap into place—hold firmly and insert slowly.

4. Install Teflon thrust bearing in inner groove of volute. Place the "0" ring in the outer groove of the volute. Place the volute against the housing and secure the assemblies with (8) screws, washers, and nuts.

**JABSCO PRODUCTS** **ITT**

Marine and Recreation Components Division  
International Telephone and Telegraph Corporation  
1485 Dale Way, Costa Mesa, California 92626  
Telephone: (714) 545-8251