

JABSCO® PUMPS

Centrifugal Series

MODEL: 17890-0001

Product Data

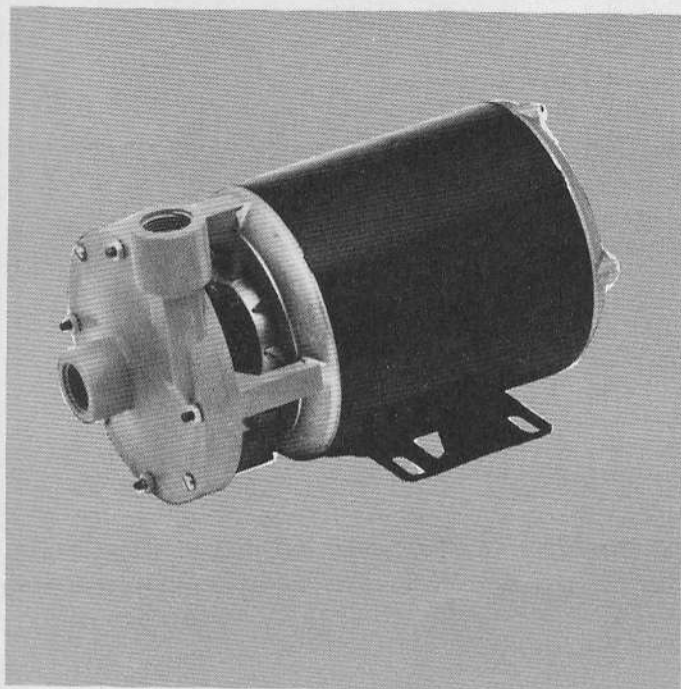

MODEL 17890-0001

DESIGN FEATURES

- Pump Material: **Plastic - CPVC/Epoxy**
- Impeller Design: **Semi-Open**
- Shaft Mechanical Seal: **Viton, Carbon/Ceramic Face**
- Suction Port Connection: **3/4" NPT or 1 1/2" Slip-On Hose**
- Discharge Port Connection: **3/4" NPT or 1 1/2" Slip-on Hose**
- Shaft: **Epoxy Stub Shaft**
- Maximum Temperature: **180°F (82.2°C)**
- Motor: **115 V., A.C., 1/3 H.P., 3450 RPM, 60 Hz, 1 Phase thermal overload protection, totally enclosed, non-vent, three prong grounded plug**
- Weight: **17½ lbs. (8 kgs.)**

MODEL 17890-0001

APPLICATION AND OPERATING INSTRUCTIONS

INDUSTRIAL— Pump designed for transfers, circulation, filtration, and drainage. Plastic body is corrosion resistant for handling corrosive fluids, photo chemicals, and many others.

OEM— Air conditioning units, laundry equipment, ice makers, vending machines, laboratory equipment, and many others.

1. **INSTALLATION** — Pump is a non self-priming centrifugal design. Flooded suction installa-

tion is recommended. Rotation is clockwise (viewed from motor end).

2. **PRIMING** — Pump must be primed before starting. Do not run dry. Damage will result.

3. **CAUTION** — Use only plastic fittings in discharge ports.

4. **LOCATION** — Pump inlet should be located below liquid surface. Keep suction and discharge line as free of elbows and valves

as practical to obtain maximum performance.

5. **SUCTION AND DISCHARGE LINES** — Both should be supported independent of pump. Suction line should be air tight. Discharge lines should be designed with minimum number of fittings and bends to reduce head loss from friction.

6. **PRIMING**—If there is some suction lift, a flap type foot valve can be used to facilitate priming.

JABSCO PRODUCTS **ITT**

EXPLODED VIEW

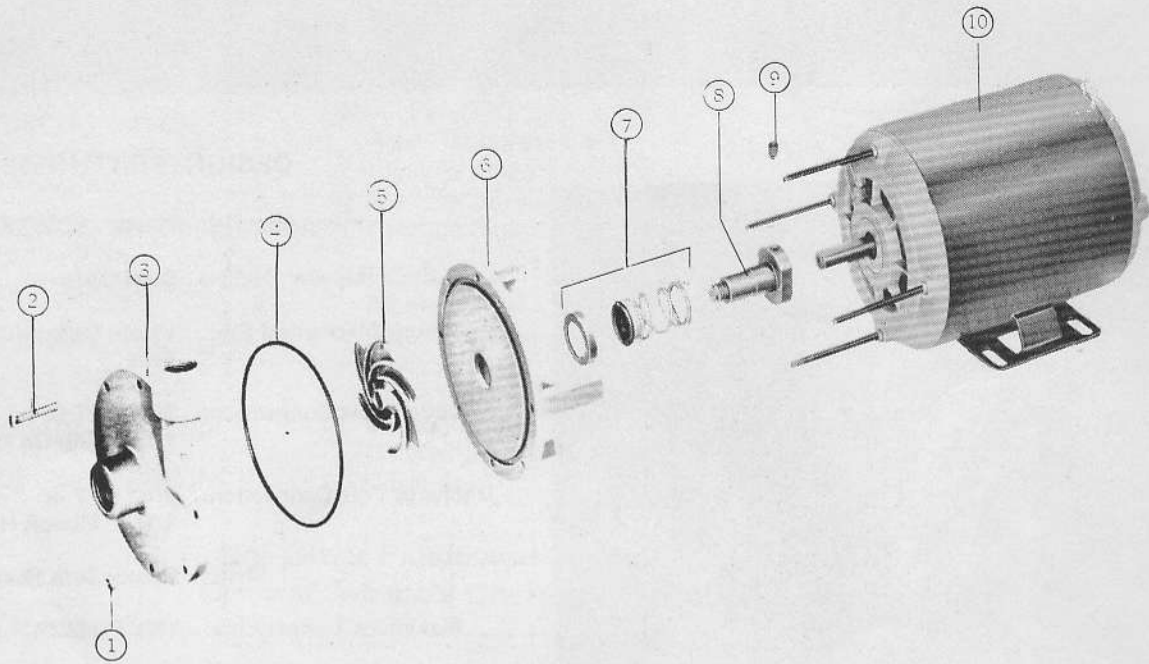

PARTS LIST

Key	DESCRIPTION	Qty. Req.	Part No.
1	Nut, Hex	4	94000-0040
2	Screw, Body	4	93950-0050
3	Pump Body	1	17884-0000
4	"O" Ring	1	92000-1120
5	Impeller	1	17885-0009
6	Seal Housing	1	17886-0000
7	Seal, Shaft	1	96080-0360
8	Shaft-Stub	1	17887-0000
9	Set Screw	2	96091-0090
10	TENV Motor	1	93004-2410

PUMP PERFORMANCE

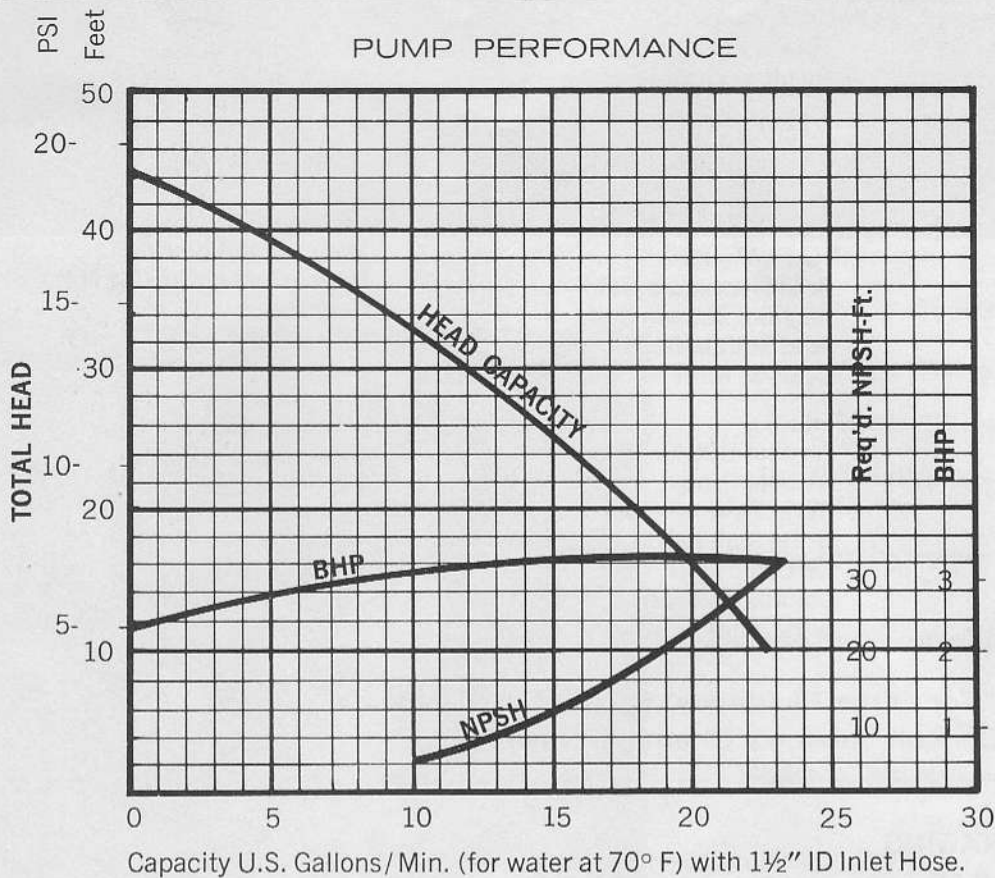

**Pump Model
17890-0001 Series**

Ports ¾" NPT or
1½" Slip-on Hose

Impeller No.
17885-0009

Speed
3450 RPM

Maximum HP
⅓

Max. Allowable Sp. Gr.
1.38 @ 40 Ft. HD
1.07 @ 10 Ft. HD

SERVICE INSTRUCTIONS

DISASSEMBLY

1. Loosen screws and nuts to remove body from seal housing.
2. Unscrew impeller from stub shaft, holding flattened shoulder to prevent stub shaft from turning.
3. Remove "O" Ring from seal housing.
4. Remove seal housing from motor.
5. Remove seal seat from seal housing.
6. Remove seal assembly from stub shaft.
7. Loosen set screws in shoulder of stub shaft and remove stub shaft from motor shaft.

ASSEMBLY

1. Coat seal housing seal bore and stub shaft with abrasive-free soap solution. (P-80 or equal)
2. Install ceramic seal seat in seal housing with ceramic face exposed. Seal face should be kept free of oil or soap.
3. Slide stub shaft onto motor shaft. Do not tighten set screws.
4. Slide seal spring over shaft and position carbon face seal element over stub shaft with carbon face outward. Do not push seal assembly down on stub shaft.
5. Locate seal housing to motor so that body discharge port will be vertical. Align carbon face of seal and seat. Press housing down in place against motor with a slight rocking motion to slip seal assembly into position over stub shaft.
6. Screw impeller onto stub shaft. Seat firmly against shoulder.
7. Hold the seal housing firmly against motor and position the impeller so there is ⅛" max clearance between the impeller back face and seal housing face. Tighten set screws in stub shaft shoulder securely.
8. Install "O" Ring in seal housing.
9. Install body on seal housing and secure with screws and nuts.

A FEW OF THE MANY CHEMICALS AND FLUIDS HANDLED:

PLATING SOLUTIONS

BRASS PLATING

- Regular Brass Bath
- High Speed Brass Bath

CADMIUM PLATING

- Cyanide Bath
- Fluoborate Bath

COPPER PLATING (ACID)

- Copper Sulfate Baths
- Copper Fluoborate

COPPER PLATING (CYANIDE)

- Copper Strike Bath
- Rochelle & Potassium Salt Baths
- Rochelle & Sodium Salt Baths
- Barrel Copper Bath

INDIUM CYANIDE PLATING

LEAD FLUOBORATE PLATING

NICKEL PLATING

- Nickel Fluoborate Bath
- All other Nickel Baths

SILVER PLATING

TIN FLUOBORATE PLATING

TIN NICKEL PLATING

ZINC PLATING

- Acid Fluoborate Bath
- Alkaline Zincate Bath
- Acid Sulfate Bath
- Cyanide Bath

OTHERS:

- Alcohol Butyl
- Alcohol Propyl
- Boric Acid
- Brine (calcium chloride)
- Carbonic acid
- Chlorox (Bleach)
- Citric Acid

OTHERS (Cont'd):

- Ferric Nitrate
- Ferric Sulfate
- Ferric Chloride
- Freon 113-TF
- Hydrochloric Acid
- Jet Fuel
- Kerosene
- Magnesium Chloride
- Magnesium Hydroxide Nitrate
- Naphtha
- Nickel Chloride
- Nitric Acid (5-10%)
- Oils (most)
- Photographic Developer
- Potassium Hydroxide
- Phosphoric Acid
- Sodium Thiosulfate
- Sodium Hypochlorite
- Water — Salt
- Water — Fresh
- Zinc Sulfate

For Other Fluids and Specific Applications
Consult Jabsco's Chemical Resistance Table

DIMENSIONAL DRAWING
MODEL 17890-0001

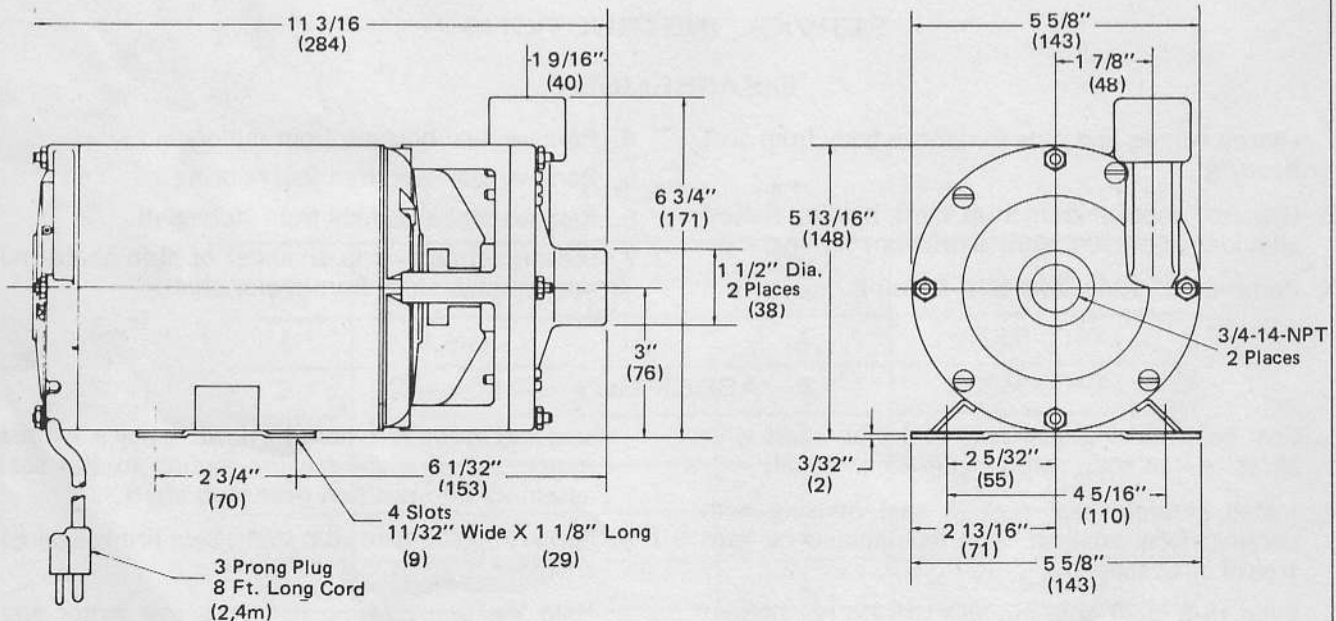

(Millimeter Equivalents)

JABSCO PRODUCTS **ITT**

Marine and Recreation Components Division
International Telephone and Telegraph Corporation
1485 Dale Way, Costa Mesa, California 92626

Telephone: (714) 545-8251