

17800 - 4000
115 V.
No. 6 mg mfg
2-7-94

Pump Only
17800-0003

**Models: 17800-1000
17800-4000**



PORTA QUICK OIL CHANGER

FEATURES

| | |
|----------------------|---|
| Pump Body: | Bronze construction |
| Impeller: | Nitrile (oil resistant) |
| Shaft Seal: | Lip type |
| Motor: | Reversible 12 Vdc with integral switch Reversible 115 Vac with integral switch |
| Container: | Plastic with 14 quart capacity |
| Power Cord: | 8 feet with alligator clips 1 foot cord with 3 prong plug |
| Suction Hose: | 4 feet of neoprene hose with 40 inch dip stick probe |
| Dimensions: | 13 1/2" (343mm) diameter, 13 5/8" (354mm) high |
| Weight: | 9 lbs. (4,1 kg) |

MODELS: 17800-1000, 17800-4000

OPERATING INSTRUCTIONS

1. Run engine approx. 5 minutes to heat oil (minimum oil temperature 140°F), then shut off engine just prior to oil removal.
2. Push neoprene suction hose on pump inlet fitting.
3. Insert nylon suction probe into nipple on suction hose.
WARNING: PUMP SWITCH MUST BE IN "OFF" POSITION WHEN CONNECTING AND DISCONNECTING ALLIGATOR CLIPS TO POSITIVE BATTERY TERMINAL AND GROUND (17800-1000 12 Vdc version) OR WHEN PLUGGING AND UNPLUGGING 3 PRONG PLUG INTO 115 Vac WALL RECEPTACLE OR EXTENSION CORD (17800-4000 115 Vac version). THE SWITCH IN AN "ON" POSITION MAY CAUSE AN ELECTRICAL SPARK WHICH CAN RESULT IN EXPLOSION. INJURY OR DEATH MAY OCCUR.
WARNING: TAKE NECESSARY PRECAUTIONS TO RID AREA AROUND BATTERY OF POTENTIALLY EXPLOSIVE GASES. CONTINUE VENTILATION DURING OIL CHANGING PROCEDURE. FAILURE TO DO SO MAY RESULT IN EXPLOSION. INJURY OR DEATH MAY OCCUR.
4. 17800-1000: Clamp power cord alligator clips to 12 Volt dc battery terminals, or 12 Volt dc battery charger (minimum 5 Amp. Cap.).
17800-4000: Plug 3 prong plug into 115 Vac wall receptacle or the proper (3 prong plug) extension cord.
5. Insert suction probe into dip stick until it bottoms.
CAUTION: Engine oil is hot. Wear protective gloves and safety glasses when handling heated oil. Failure to do so may result in personal injury.
6. Switch to "ON" position in direction of flow from engine to container. Watch for oil flow through suction probe. If oil does not rise within 10 seconds, turn off pump, check suction probe for sediment blockage.
7. Motor will overspeed when oil has been pumped out of engine. Switch off pump immediately to avoid impeller damage. Do not leave pump untended while pumping oil from engine. Normal 6 quart pump-out takes less than 3 minutes.
8. After oil has been pumped from engine, remove nylon suction probe from nipple and coil on lid of container for storage. Loop suction hose and secure to handle of container with chain hanger, insuring nipple points up to prevent oil drippage. Coil power cord and secure to handle with chain hanger.
9. To empty container, switch to "ON" position in direction of flow from container to approved oil disposal receptacle. If 12 Vdc or 115 Vac power is not available, pull up retractable pour spout and empty container.

PUMP EXPLODED VIEW

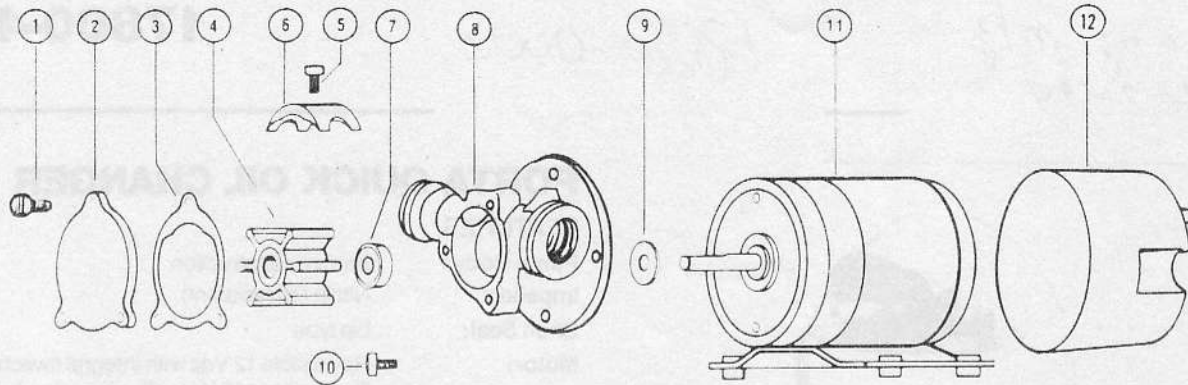

SERVICE INSTRUCTIONS

DISSASSEMBLY

1. Remove hoses from port adaptors.
2. Remove end cover screws, end cover and gasket.
3. Withdraw impeller.
4. Loosen and remove two slotted hex screws, which attach body to motor.
5. Tap body lightly between ports and remove body from motor.
6. Deform seal and remove from body cavity.
NOTE: Do not tamper with or disassemble motor.

ASSEMBLY

1. Lubricate seal. Deform seal and install in cavity with open side of seal facing impeller bore.
2. Lubricate motor shaft and install body on motor.
3. Lubricate impeller bore and, aligning flat in impeller with flat on motor shaft, install impeller.
4. Install gasket, end cover and screws.
5. Attach hoses to port adaptors.

| KEY | DESCRIPTION | PART NUMBER | 17800-1000 QTY. | 17800-4000 QTY. |
|-----|-----------------------|-------------|-----------------|-----------------|
| 1 | Screw (End Cover) | 91002-0090 | 3 | 3 |
| 2 | End Cover | 12076-0000 | 1 | 1 |
| 3* | Gasket | 7828-0000 | 1 | 1 |
| 4* | Impeller, Nitrile | 14750-0003 | 1 | 1 |
| 5 | Screw (Cam) | 91002-0010 | 1 | 1 |
| 6 | Cam | 8089-0000 | 1 | 1 |
| 7* | Seal | 93000-0010 | 1 | 1 |
| 8 | Body | 7824-0000 | 1 | 1 |
| 9 | Slinger | 6342-0000 | 1 | 1 |
| 10 | Screw (Body to Motor) | 98019-0060 | 2 | |
| | | 98019-0020 | | 2 |
| 11 | Motor 12 Vdc | 18753-0067 | | |
| | 32 Vdc | 18753-0068 | | |
| | 115 Vac | 18753-0164 | | |
| 12 | Switch/Housing Assy. | 18753-0069 | | |
| | Service Kit, Nitrile | 90092-0004 | | |

* Parts contained in Service Kit



| KEY | DESCRIPTION | PART NUMBER | QTY. |
|-----|-------------------------|-------------|------|
| 1 | Lid | 17794-0000 | 1 |
| 2 | Power Cord (-1000 Only) | 43922-0000 | 1 |
| 3 | Pail | 17089-0000 | 1 |
| 4 | Hose Adaptor Plastic | 34378-0000 | 1 |
| 5 | Hose Adaptor Rubber | 33857-0000 | 1 |
| 6 | Dip Stick Probe | 33815-0040 | 1 |
| 7 | Hose | 17795-0000 | 1 |
| 8 | Port Adaptor 90° | 93009-0180 | 1 |
| 9 | Port Adaptor Straight | 93009-0190 | 1 |

ITT JABSCO

A Unit of ITT Corporation
 1485 Dale Way, P.O. Box 2158
 Costa Mesa, California 92628-2158
 Telephone: (714) 545-8251
 Form 43000-0037 Rev. 9/88