

**JABSCO®****Model: 17800-1000**

## PORTA QUICK OIL CHANGER

### FEATURES

- Pump Body:** Bronze construction  
**Impeller:** Nitrile (oil resistant)  
**Shaft Seal:** Lip Type  
**Motor:** Reversible 12 V DC (5 amp) with integral switch  
**Container:** Plastic with 14 quart capacity  
**Power Cord:** 12 V DC - 8 feet with alligator clips  
**Suction Hose:** 4 feet of neoprene hose with 40 inch dip stick probe  
**Dimensions:** 13-1/2" (343mm) diameter, 13-5/8" (354mm) high  
**Weight:** 9 lb (4,1 kg)

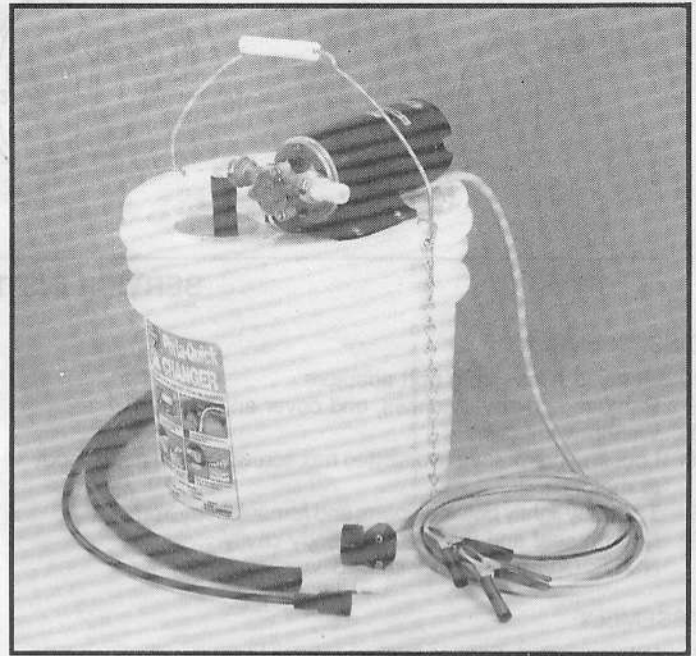

Model: 17800-1000

### OPERATING INSTRUCTIONS

- Run engine approx. 5 minutes to heat oil (minimum oil temperature 140°F; maximum 185°F), then shut off engine just prior to oil removal.
- Push neoprene suction hose on pump inlet fitting.
- Insert nylon suction probe into nipple on suction hose.
- 17800-1000: Clamp power cord alligator clips (red to positive and black to negative) to 12 Volt dc battery terminals.
- Insert suction probe into dip stick until it bottoms. Then pull it back up about 1/8" – 1/4". Hold the probe in that position or secure it in place with tape.
- Switch to "ON" position in direction of flow from engine to container. Watch for oil flow through suction probe. If oil does not rise within 10 seconds, turn off pump, check suction probe for sediment blockage. If motor does not turn - switch off pump, loosen end cover and turn on again momentarily until it rotates. Switch back to off. Retighten end cover and begin again.
- Motor will overspeed when oil has been pumped out of engine. Switch off pump immediately to avoid impeller damage. Do not leave pump unattended while pumping oil from engine. Normal 6 quart pump-out takes less than 3 minutes.
- After oil has been pumped from engine, remove nylon suction probe from nipple and coil on lid container for storage. Loop suction hose and secure to handle of container with chain hanger, insuring nipple points up to prevent oil drippage. Coil power cord and secure to handle with chain hanger.
- To empty container with pump when appropriate electrical power is nearby, remove 1/4" probe adaptor from 48" hose and insert hose end in approved receptacle. Do not attempt to discharge oil through 1/4" probe. Connect power cord to proper power supply and switch on pump by moving switch toggle in the direction of desired flow. If proper electrical power is not available, pull up retractable pour spout and carefully pour oil into a suitable receptacle.

**WARNING**

Explosion hazard. Pump switch must be in "OFF" position when connecting and disconnecting alligator clips to positive battery terminal and ground. The switch in an "on" position may cause an electrical spark which can result in explosion. Injury or death may occur.

**WARNING**

Explosion hazard. Take necessary precautions to rid area around battery of potentially explosive gases. Continue ventilation during oil changing procedure. Failure to do so may result in explosion. Injury or death may occur.

**CAUTION:** Engine oil is hot. Wear protective gloves and safety glasses when handling heated oil. Failure to do so may result in personal injury.

**Notice:** Always recycle used oil in compliance with federal and local legislation. Handle petroleum products in an environmentally responsible manner.

PUMP EXPLODED VIEW

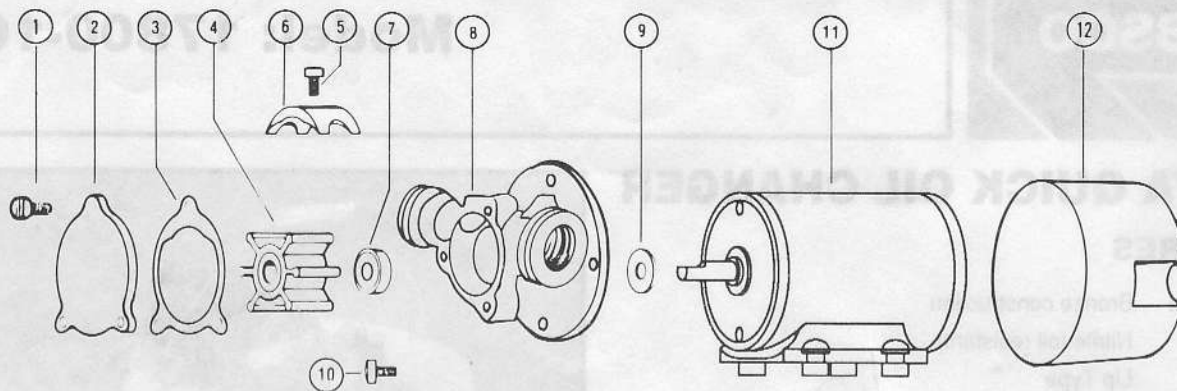

SERVICE INSTRUCTIONS

DISSASSEMBLY

1. Remove hoses from port adaptors.
2. Remove end cover screws, end cover and gasket.
3. Withdraw impeller.
4. Loosen and remove two slotted hex screws, which attach body to motor.
5. Tap body lightly between ports and remove body from motor.
6. Deform seal and remove from body cavity.  
NOTE: Do not tamper with or disassemble motor.

ASSEMBLY

1. Lubricate seal. Deform seal and install in cavity with open side of seal facing impeller bore.
2. Lubricate motor shaft and install body on motor.
3. Lubricate impeller bore and, aligning flat in impeller with flat on motor shaft, install impeller.
4. Install gasket, end cover and screws.
5. Attach hoses to port adaptors.

KEY	DESCRIPTION	PART NUMBER	17800-1000 QTY.
1	Screw (End Cover)	91002-0090	3
2	End Cover	12076-0000	1
3*	Gasket	7828-0000	1
4*	Impeller, Nitrile	14750-0003	1
5	Screw (Cam)	91002-0010	1
6	Cam	8089-0000	1
7*	Seal	93000-0010	1
8	Body	7824-0000	1
9	Slinger	6342-0000	1
10	Screw (Body to Motor)	98019-0060	2
11	Motor 12 Vdc	18753-0067	1
12	Switch/Housing Assy.	18753-0069	1
	Service Kit, Nitrile	90092-0004	
	Replacement Pump Head	9040-0005	

\* Parts contained in Service Kit

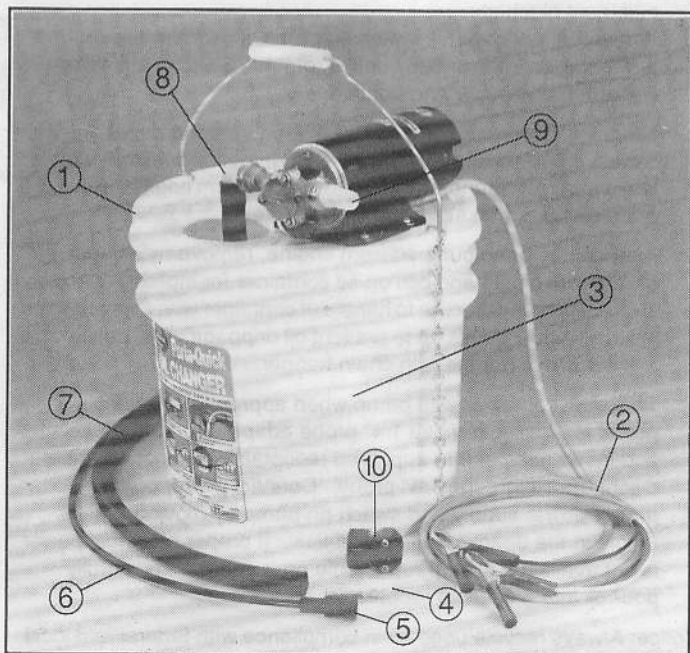

KEY	DESCRIPTION	PART NUMBER	QTY.
1	Lid	17794-0000	1
2	Power Cord (-1000 Only)	43922-0000	1
3	Pail	17089-0000	1
4	Hose Adaptor Plastic	34378-0000	1
5	Probe Adaptor Rubber	33857-0000	1
6	Dip Stick Probe	33815-0040	1
7	Hose	17795-0000	1
8	Port Adaptor 90°	93009-0180	1
9	Port Adaptor Straight	93009-0190	1
10	1/2" Hose by Female Garden Hose Thread Fitting	-	1

**ITT Jabsco**

ITT Fluid Technology Corporation  
 1485 Dale Way, P.O. Box 2158, Costa Mesa, CA 92628-2158  
 Tel: (714) 545-8251; Fax: (714) 957-0609  
 Bingley Road, Hoddesdon, Hertfordshire EN11 OBU England  
 Tel: 0992-467191; Tlx: 263251 G; Fax: 0992-467132