

JABSCO® PUMPS

Self-Priming Macerator Pump Units

MODEL: 17260 - Series

Product Data



17260-0003 - 12 Volt
17260-0023 - 24 Volt
17260-0033 - 32 Volt

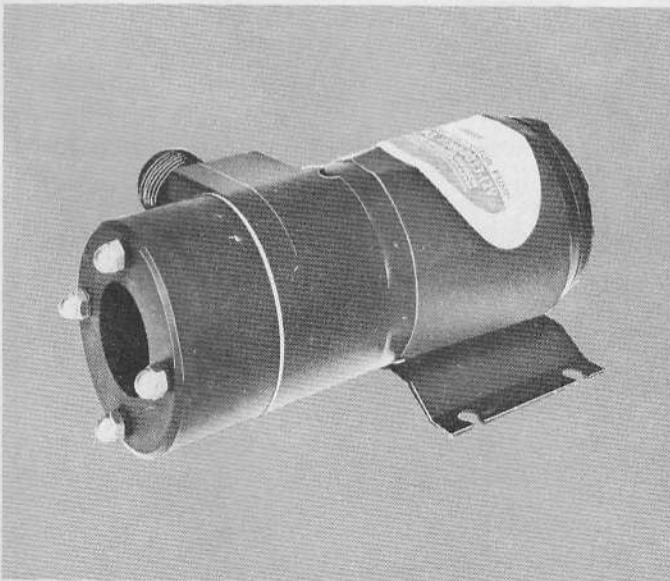

17260-0013 - 12 Volt

DESIGN FEATURES

- Pump: **Self-Priming Flexible Impeller with Stainless Steel Wearplates**
- Impeller: **Jabco Nitrile Compound**
- Macerator: **Stainless Steel Cutter Plate reduces particle size to 1/8" maximum**
- Seal: **Lip Type**
- Ports: **Model 17260-0003**
Inlet — 1 1/2" External Pipe Thread
Outlet — 3/4" Garden Hose Thread
- Model 17260-0013**
Inlet — 3" Slip-on Hose
Outlet — 3/4" Garden Hose Thread
- Motor: **Permanent Magnet Type, Fully Enclosed, with Stainless Steel Shaft**
- Weight: **7 lbs. (3.2 kg.) Approx.**

APPLICATION INFORMATION

The 17260 series D. C. JABSCO macerator pump unit is the ideal answer to holding tank pump out problems for boats and recreational vehicles. The macerator section grinds waste down to a particle size of 1/8" maximum so it can easily be pumped through a garden hose discharge line. The pump section is self priming, permitting the unit to be mounted above the tank in a convenient location.

Empties most recirculating toilets in less than two minutes; empties a 30 gallon holding tank in less than 5 minutes.

The 17260 series waste pump will macerate and pump all waste and tissue normally found in marine and recreational vehicle waste systems. It will NOT handle hard solid objects, sanitary napkins or rags.

MODEL: 17260-SERIES

JABSCO PRODUCTS **ITT**

TYPICAL MARINE USES

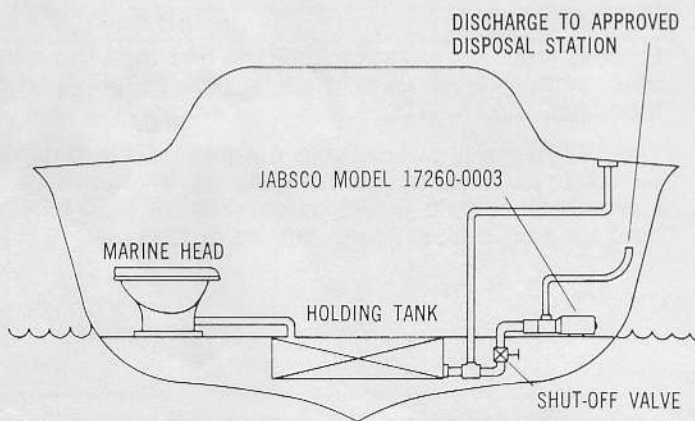
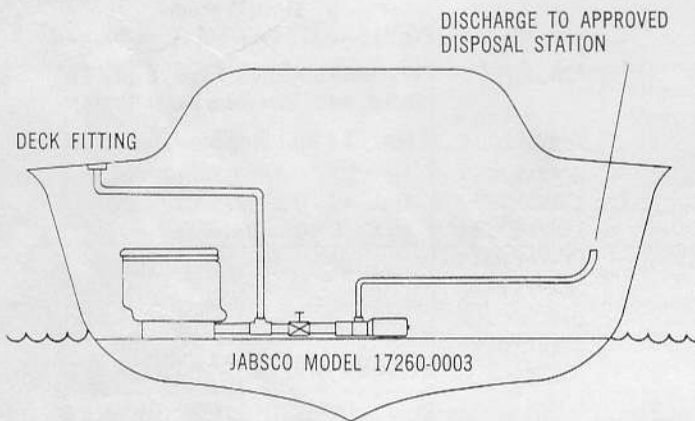
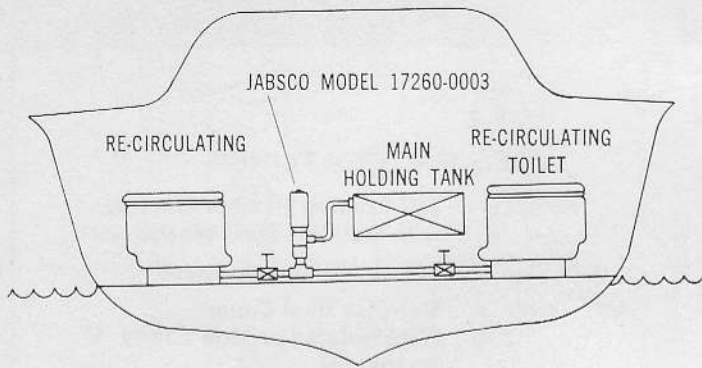

TYPICAL RECREATIONAL VEHICLE USES

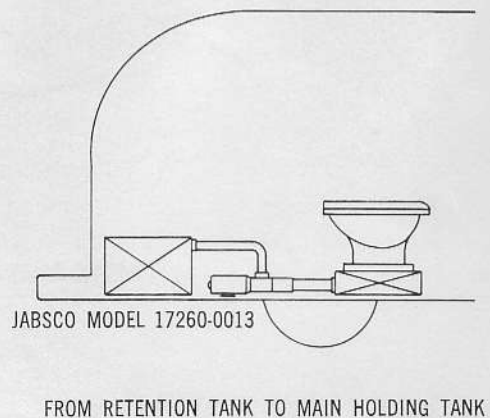
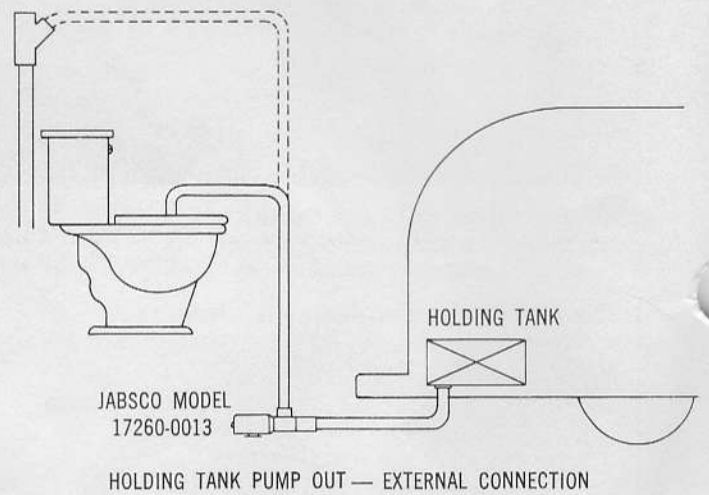
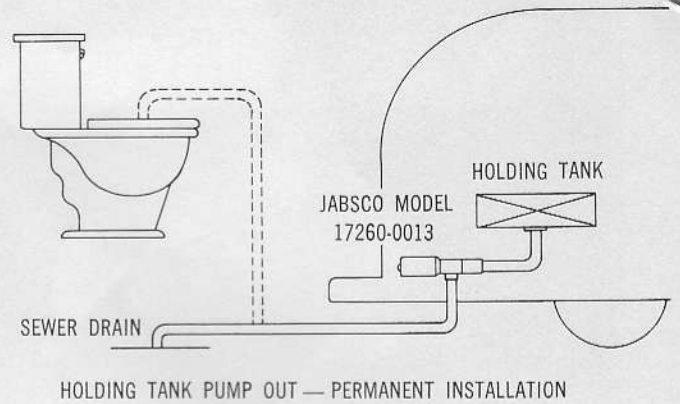

INSTALLATION INSTRUCTIONS

Locating the Pump: The JABSCO macerator pump is self priming to a four feet lift and may be located at any convenient point in the waste discharge system. It may be mounted in any position or angle without affecting performance. Use the rubber grommets provided to absorb vibration. Do not overtighten mounting screws.

Plumbing Connections: For model 17260-0003, 0023, and -0033, use minimum 1 1/2" ID non collapsible suction hose. Two inch hose may be slipped over the inlet and clamped on smooth area of port. For model 17260-0013, use 3" ID non collapsible hose and clamp on outside diameter of macerator housing.

All suction connections must be airtight and free of sharp bends or restrictions. Use minimum 3/4" inside diameter garden or contractors hose for discharge.

Wiring Hookup: For permanent connection, use heavy duty stranded copper wire to avoid excessive voltage drop. Consult recommended wire size and fuse table for correct size.

IMPORTANT

Connect orange wire to positive circuit and black wire to negative for proper rotation. Failure to connect wires as described will damage unit and void warranty.

OPERATING INSTRUCTIONS

Operation: The JABSCO macerator pump unit has been designed to handle waste, toilet tissue, and facial tissue. It will also handle solids such as filter tip cigarettes, cigars and chunks of soft fruits or vegetables less than 1" size. It will not pump solid objects like peach pits, rags, or sanitary napkins. The holding

tank and pump should be flushed with several gallons of water after each pumpout. Do NOT run pump dry. Make sure the battery is fully charged. The D.C. motor is suitable only for intermittent duty, do not run for more than 6 or 7 minutes continuously.

DIMENSIONAL DRAWING

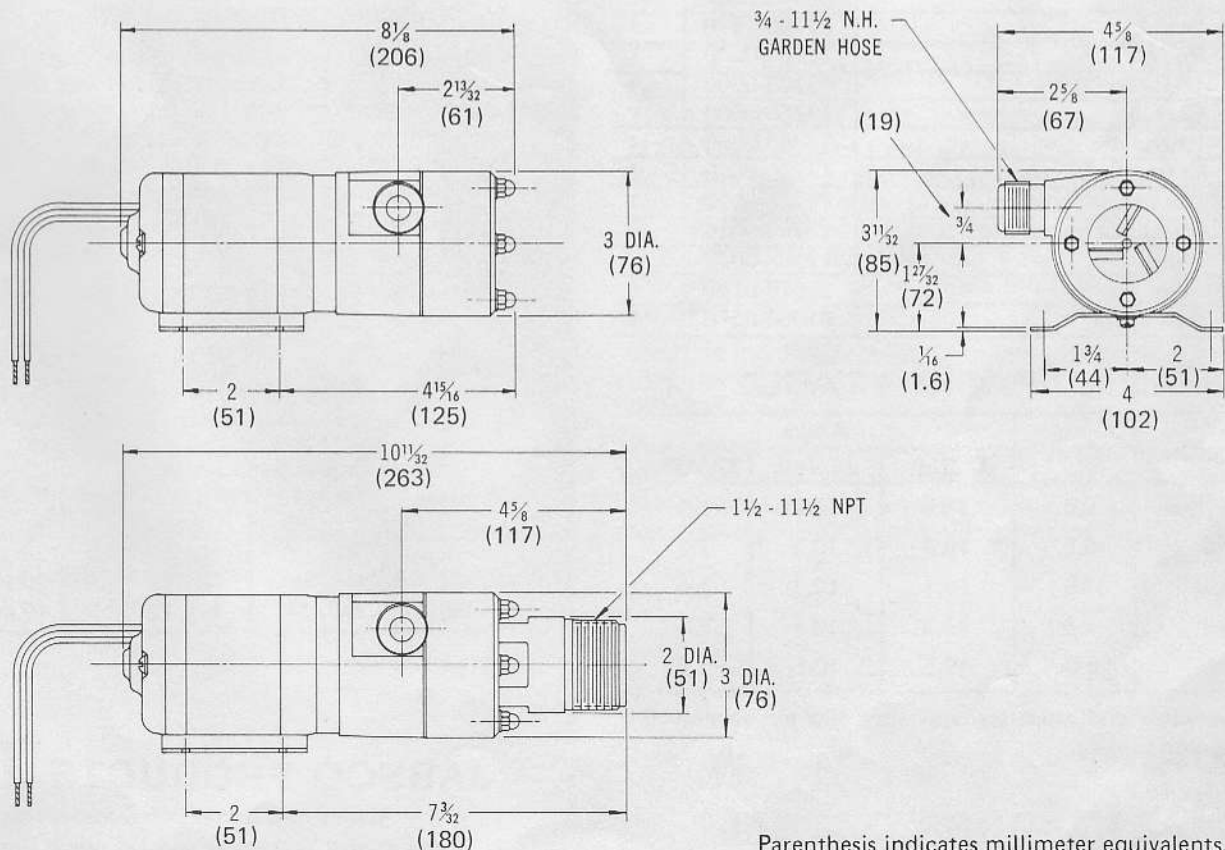

Parenthesis indicates millimeter equivalents.

EXPLODED VIEW

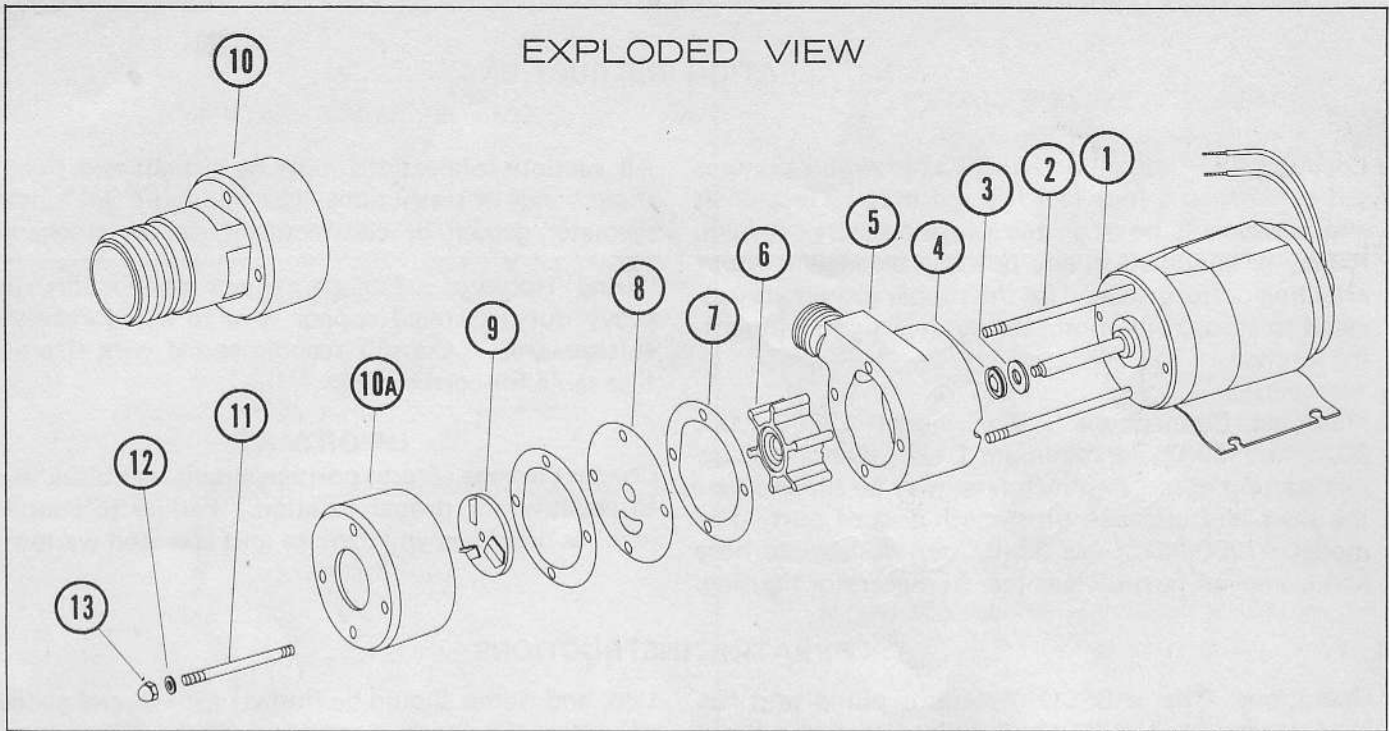

PARTS LIST

Key	Description	Part No.	Qty. Req.
1	Motor Sub-Assembly - 12 Volt	17246-0000	1
	Motor Sub-Assembly - 24 Volt	17246-0001	1
	Motor Sub-Assembly - 32 Volt	17246-0002	1
2	Stud	17288-0000	2
3	Slinger	06342-0000	1
4	Seal	92700-0910	1
5	Body	17267-0000	1
6	Impeller	06303-0003	1
7	Gasket	17269-0000	2
8	Wearplate	17268-0000	1
9	Cutter Plate	17266-0000	1
10	Macerator Housing	17263-0000	1
10A	Macerator Housing	17263-0010	1
11	Stud	17288-0010	2
12	Fiber Washer	91613-0140	4
13	Acorn Nut	91085-0340	4

HEAD CAPACITY TABLE*

Head Ft	GPM	Amps		
		12 Volt	24 Volt	32 Volt
Free flow	9.0	18.8	10.0	7.0
5	8.5	19.0	10.2	7.2
10	7.8	19.1	10.3	7.4
15	7.0	19.3	10.4	7.6
20	6.0	19.5	10.5	7.8

*Flow rates and amperage will vary slightly depending on pump loading.

SERVICE INSTRUCTIONS

1. Remove acorn nuts #91085-0340 and inlet housing #17263-0000.
2. Unscrew cutter plate from shaft by turning counterclockwise facing cutter blades. (Hold motor shaft behind plate to prevent turning.)
3. Remove gaskets, wearplate and slide pump assembly off mounting studs.
4. Replace seal, impeller gaskets or other parts as necessary. To remove seal, push out evenly with screwdriver from impeller bore side of body. To reassemble seal, coat outside of metal case with Permatex or similar sealant and press into body with lip facing impeller. A light coating of grease should be applied to impeller bore and wearplate to aid initial dry startup.
5. Reassemble body, impeller, gaskets, wearplate, suction housing and acorn nuts.

RECOMMENDED WIRE AND FUSE SIZE

Voltage	Wire Size Connection Length Between Battery and Motor		Fuse
	1' to 10'	10' to 20'	
	12	No. 12	
24	No. 14	No. 12	20 amp.
32	NO. 14	No. 12	10 amp.

JABSCO PRODUCTS **ITT**

Marine and Recreation Components Division
International Telephone and Telegraph Corporation
1485 Dale Way, Costa Mesa, Calif. 92626 (714)545-8251