

# Installation and Operating Instructions For Jabsco® Permanent Oil Drain Kit. Model 17215 - 0004

## TO ATTACH DRAIN HOSE AND FITTING

**TOOLS REQUIRED:** 1/4" drill chuck electric drill; adjustable wrench to remove oil drain plug, and install oil drain fitting and hose; Teflon tape for thread sealing; and 2 gallon can or pail.

1. Start engine. Run at idle for about 10 minutes to heat oil. (Hot oil is thin and flows faster.)
2. While engine oil is heating, attach probe adaptor and dipstick probe to suction port of pump\*. Slip green hose on discharge port of pump. Secure pump shaft in electric drill chuck. (See Figure 1)

**\*NOTE:**  
To prevent probes from entering port and damaging impeller, wrap a 6" strip of 1/2" adhesive tape around probe to form a collar, 1" from either end.

3. Turn off engine. Run probe through fingers several times to straighten it. Remove dipstick and insert probe into dipstick tube till it bottoms. To prevent probe from making a return bend, gage approximate length of insertion by measuring against dipstick. If probe cannot be inserted in dipstick tube, drain oil in conventional manner. (See Figure 1)

4. Pump engine oil into two-gallon container. When oil stops flowing in a steady stream from the discharge hose, move probe up and down to drain the last of the oil. Remove probe from the dipstick tube using a rag to wipe the drips.

5. Place a carton under pan to catch oil drips as you loosen and remove oil drain plug. (See Figure 3)

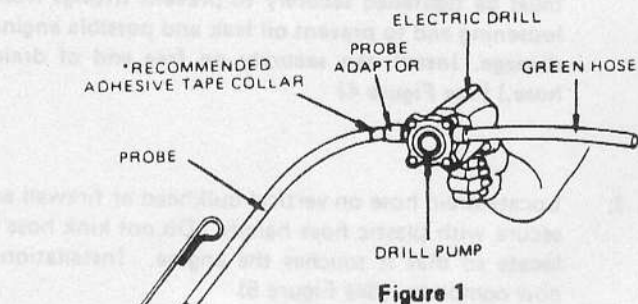

Figure 1

Mark with grease pencil or white paint, for approximate depth of insertion in dipstick tube.

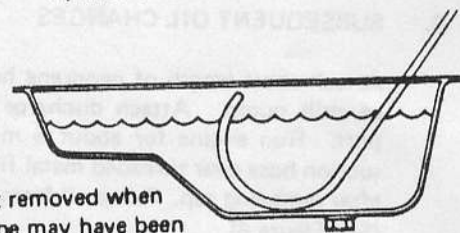

Figure 2

If all oil is not removed when pumping, probe may have been inserted too far into dipstick tube and made a return bend. Remove probe, straighten and gage length of insertion by measuring against dip stick.

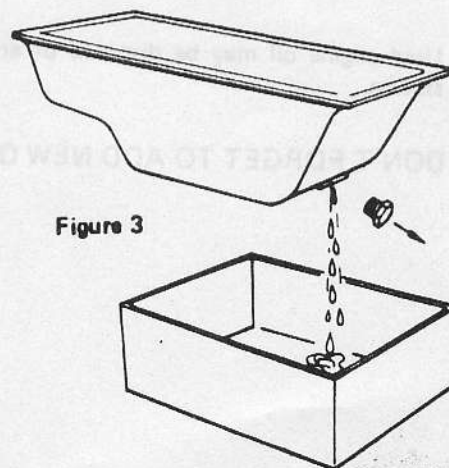

Figure 3

6. Wrap threads of hex drain fitting with teflon tape, or apply thread compound. Make sure nylon washer is in place between engine pan and hex drain fitting. Install hex drain fitting in pan securely. Wrap threads of black drain hose with teflon tape or apply thread compound. Install black drain hose in hole which will provide the most direct path to convenient hanger location on vertical bulkhead or firewall. Wrap plug with teflon tape or apply thread compound and install in remaining hole securely. (CAUTION: Oil drain fitting and oil drain hose must be tightened securely to prevent fittings from loosening and to prevent oil leak and possible engine damage. Install cap securely on free end of drain hose.) (See Figure 4)

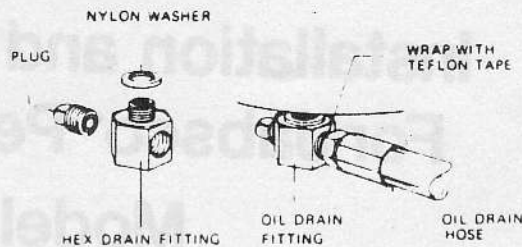

Figure 4

7. Locate drain hose on vertical bulkhead or firewall and secure with plastic hose hanger. Do not kink hose or locate so that it touches the engine. Installation is now complete. (See Figure 5)

Fill engine with required quantity of motor oil.

#### 8. SUBSEQUENT OIL CHANGES

Attach short length of neoprene hose to suction port of drill pump. Attach discharge hose to discharge port. Run engine for about 5 minutes. Slip pump suction hose over threaded metal fitting of drain hose, after removing cap. Pump oil from engine. (See Figure 6)

Remove pump from oil drain hose, replace cap and secure hose with hose hanger to bulkhead. Add oil to engine.

Used engine oil may be disposed of at local service station.

**DON'T FORGET TO ADD NEW OIL TO ENGINE!!**

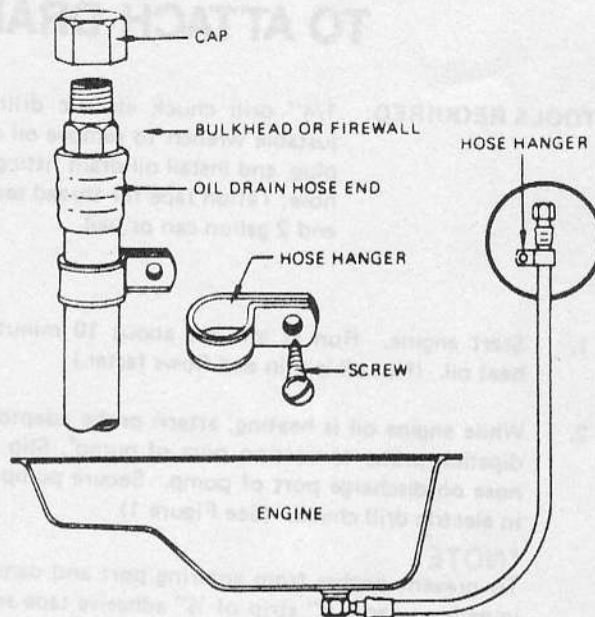

Figure 5

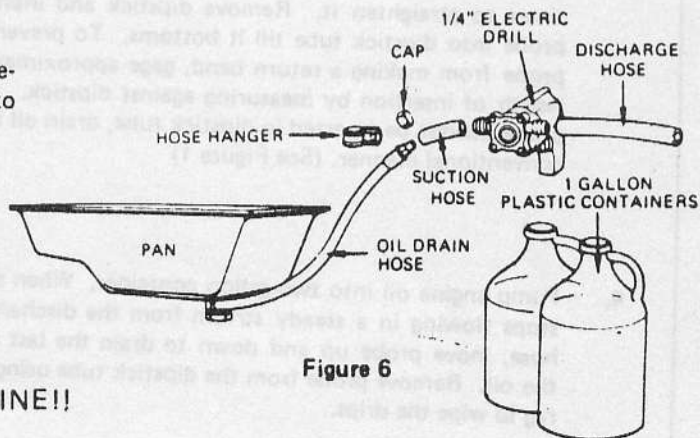

Figure 6

## JABSCO PRODUCTS **ITT**

Marine and Recreation Components Division  
International Telephone and Telegraph Corporation  
1485 Dale Way, Costa Mesa, California 92626  
Telephone (714) 545-8251