

JABSCO®

Model 17120-0001

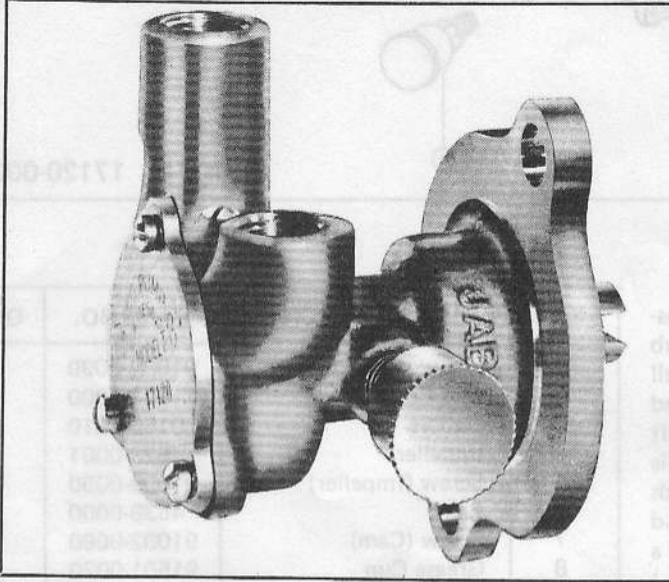

Engine Coolant Pump FEATURES

Body: Bronze
Impeller: Jabsco Neoprene Compound
Shaft: 316 Stainless Steel
Shaft Seal: Lip Type
Ports: 3/8" NPT
Weight: Approx. Shipping Wght. 3 lb

APPLICATION:
Marine Engine Cooling

FOR ENGINE MODELS:
Universal Atomic Four

Model 17120-0001

MODEL: 17120-0001

DIMENSION DRAWING

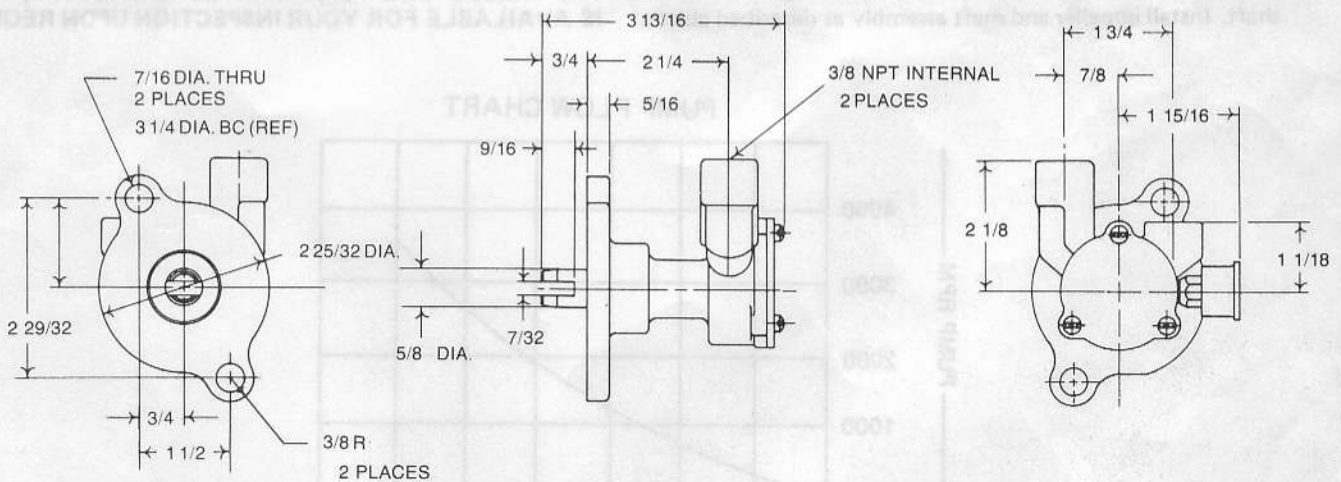

INSTALLATION INSTRUCTIONS

Engage shaft with drive tang, make sure flange seats squarely on mounting surface and bolt to engine. Connect inlet and outlet fittings using pipe compound to seal threads.

OPERATING INSTRUCTIONS

Pump will self prime at low or high speeds. Make sure scoop and inlet line are clear and all connections air tight. Do not run pump dry for more than 30 seconds. Lack of water flow may damage impeller. To drain pump, loosen end cover screws.

EXPLODED VIEW

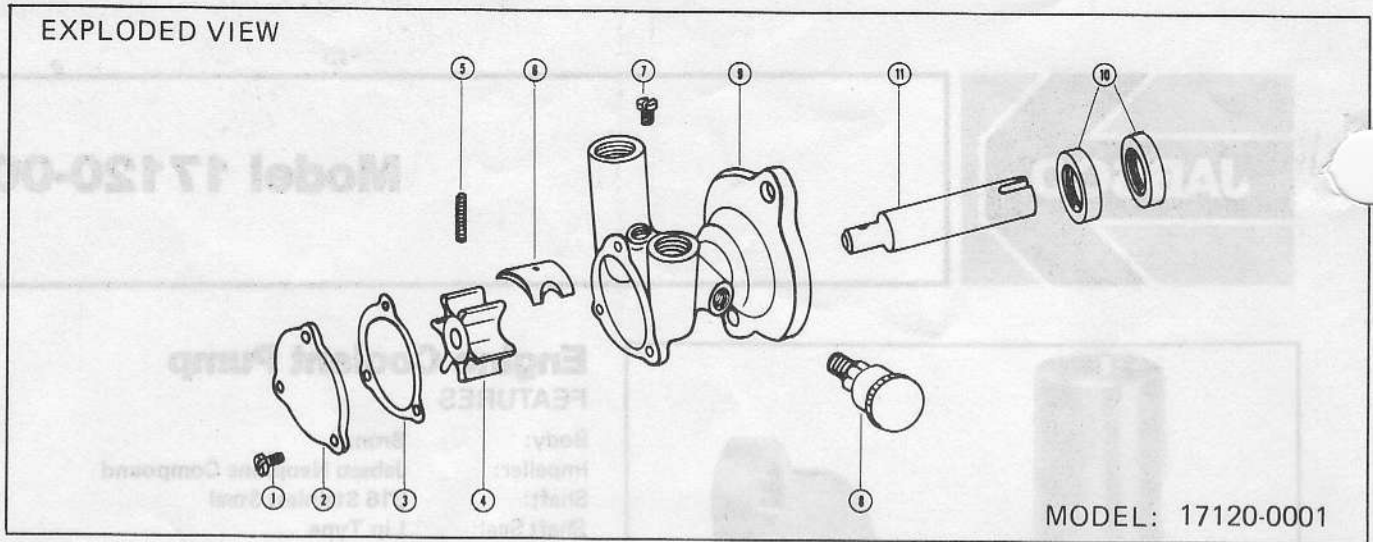

MODEL: 17120-0001

SERVICE INSTRUCTIONS

IMPELLER REPLACEMENT: Remove end cover and gasket. Pull impeller and shaft assembly out by grasping hub or blades with pliers. Remove impeller screw and pull impeller off of shaft. Install new impeller on shaft and secure with screw. Lubricate impeller bore and install shaft and impeller assembly in body. (Make sure tang drive is lined up correctly, before pushing impeller in flush with body.) Lubricate face of impeller, install gasket and end cover, secure with screws. (Use correct Jabsco gasket; a thicker or thinner gasket may cause impeller damage.) Standard gasket is .010" thick.

MAJOR REPAIR: Follow steps outlined above to remove shaft and impeller assembly. Remove seals from bearing bore.

TO ASSEMBLE: Lubricate lip of inboard seal and install in body, with lip facing impeller bore. Lubricate lip of outboard seal and install in body, with lip facing drive end of shaft. Install impeller and shaft assembly as described above.

KEY	DESCRIPTION	PART NO.	QTY.
1	Screw (End Cover)	91002-0090	4
2	End Cover	11833-0000	1
3*	Gasket	9156-0010	1
4*	Impeller	4528-0001	1
5	Screw (Impeller)	91009-0050	1
6	Cam	4538-0000	1
7	Screw (Cam)	91002-0090	1
8	Grease Cup	91501-0020	1
9	Body	17124-0000	1
10*	Lip Seal	92700-0060	2
11	Shaft	17127-0000	1
	Service Kit	90178-0001	1

*Parts Contained in Service Kit

THE PRODUCT DESCRIBED HEREIN IS SUBJECT TO THE JABSCO ONE YEAR LIMITED WARRANTY, WHICH IS AVAILABLE FOR YOUR INSPECTION UPON REQUEST.

PUMP FLOW CHART

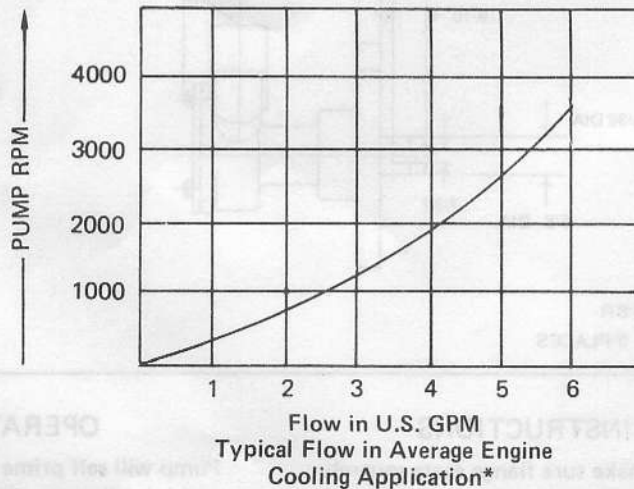

*Average engine cooling applications have discharge pressures of 10-15 p.s.i. and intake vacuums of 3-5 inches of mercury.

ITT Jabsco

ITT Fluid Technology Corporation

1485 Dale Way, P.O. Box 2158, Costa Mesa, Ca 92628-2158

Tel: (714) 545-8251; Fax: (714) 957-0609

Bingley Road, Hoddesdon, Hertfordshire EN11 OBU, England

Tel: 0992-467191; Tlx: 26351 G; Fax: 0992-467132