



Model 1673-Series

SELF-PRIMING PUMPS

FEATURES

- Body:** Bronze
- Impeller:** Neoprene or Nitrile (Oil Resistant)
- Shaft:** Stainless Steel
- Shaft Seal:** Lip Seal, Buna N
- Bearings:** Sealed Ball Bearings
- Ports:** 1/2" NPT
- Weight:** 4-1/4 lb (2 kg) approx.

VARIATIONS AVAILABLE

MODEL	VARIATIONS
1673-1001	Neoprene Impeller
1673-1003	Nitrile Impeller (Oil Resistant)
1673-1051	Half Thickness Cam, (Where reduced capacity is required with a fixed speed)



Model 1673-Series

APPLICATIONS & OPERATING INSTRUCTIONS

MARINE: Engine cooling, Pumping bilges, Washdowns, Circulating water in bait tanks, Utility dock side pump.

INDUSTRIAL: Circulating and transferring, Velocity-mixing, Pumping machine tool coolants, Return spill, Sump drainage, Chemicals, Pharmaceuticals, Soap, Liquors, Ink, Dyes, Alcohol, Various acids, Tanning liquors, Glycerine, Brine, etc.

FARMING: Pumping water for stock, Pumping water from shallow wells and cisterns, Pumping liquid ballast into tractor tires.

PLUMBING AND HOME EMERGENCY USE: Pumping out flooded basements, Cesspools, Sumps, Water heaters and water closets, Drains and sinks, Draining fishponds and pools.

1. INSTALLATION – Pump may be mounted in any position. Intake and discharge ports are determined by the direction of shaft rotation (refer to Dimensional Drawing). Before installing, turn the pump shaft in the direction of the operating rotation.

2. DRIVE – Belt or Direct with flexible coupling.

NOTICE: Do not press pulley or coupling on the shaft without supporting the shaft at the opposite end to prevent its movement into the impeller bore.

Belt Drive – Overtight belt load will reduce pump bearing life.

Direct Drive – Clearance should be left between drive shaft and pump shaft when installing coupling. Always mount and align pump and drive shaft before tightening the coupling set screw.



WARNING Injury hazard. Exposed pulleys and belts can cause injury. Install shield around pulleys and belts. Stay clear while machinery is operating.

3. SPEEDS – 100 RPM to the maximum shown in the performance table. Consult the factory for operation at speeds above those shown. For longer pump life, operate at lowest possible speeds.

4. SELF-PRIMING – Primes at low or high speeds. For vertical lift of 10 feet (3.0m), a minimum of 800 RPM is required. Pump will produce suction lift of up to 22 feet (6.7m) when wetted. **BE SURE SUCTION LINES ARE AIRTIGHT OR PUMP WILL NOT SELF-PRIME.**

5. RUNNING DRY – Unit depends on liquid pumped for lubrication. **DO NOT RUN DRY** for more than 30 seconds. Lack of liquid will damage the impeller.

6. NOTICE – Do not pump light fraction petroleum derivatives, solvents, thinners, highly concentrated or organic acids. Damage to pump may result. Consult Jabsco Chemical Resistance Table, available upon request from Jabsco, for proper body materials and impeller compounds. If corrosive fluids are handled, pump life will be prolonged if pump is flushed with water after each use or after each work day.

OPERATING INSTRUCTIONS (Cont.)

7. PRESSURES - Consult Head Capacity Table for recommended maximum for continuous operation. If pressures exceed those shown, consult the factory.

8. TEMPERATURES - Neoprene 45°-180° F (7°-82° C), Nitrile 50°-180° F (10°-82° C).

9. FREEZING WEATHER - Drain unit by loosening end cover. The following anti-freeze compounds can be used without any adverse effects to the neoprene impeller:

Atlas "Permaguard", DuPont "Zerex" and "Telar", Dow Chemical "Dowguard" and Olin Mathison "Pyro Permanent". Most methyl alcohol (methanol) based antifreeze can be used with neoprene. **(DO NOT USE PETROLEUM BASED ANTI-FREEZE COMPOUNDS OR RUST INHIBITORS.)**

10. SPARE PARTS - To avoid costly shut downs, keep a JABSCO Service Kit on hand.

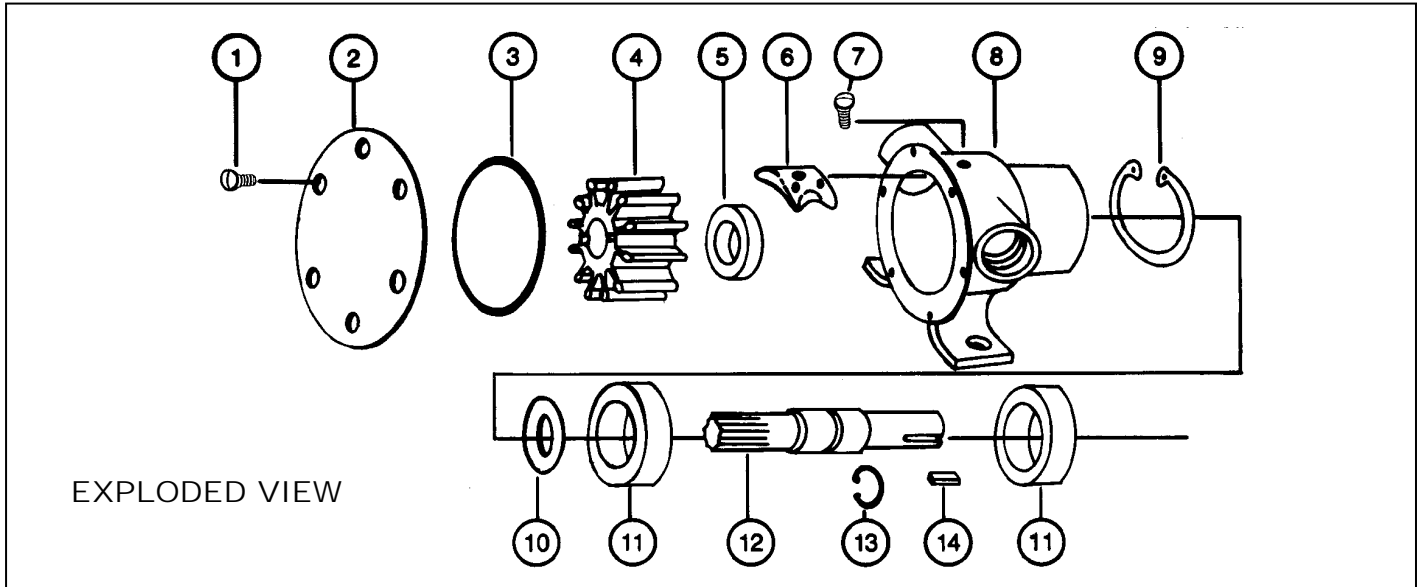

PARTS LIST

KEY	DESCRIPTION	PART NO.	QTY
1	SCREW KIT (CAM & END COVER SCREWS)†	18753-0134	1
2	ENDCOVER	11836-0000	1
3	*O-RING	18753-0133	1
4	*IMPELLER NEOPRENE NITRILE	1210-0001 1210-0003	1
5	*SEAL	92700-0060	1
6	CAM FULL THICKNESS HALF THICKNESS	490-0001 2434-0000	1
7	SCREW, CAM	SEE KEY1	
8	BODY	18753-0128	1
9	RETAINING RING	18753-0131	1
10	SLINGER	3286-0000	1
11	BEARING	92600-0120	2
12	SHAFT	18753-0129	1
13	RETAINING RING	18753-0132	1
14	KEY	9215-0010	1
	SERVICE KIT NEOPRENE NITRILE	90015-0001 90015-0003	

* Parts supplied in Service Kit. Also included is an end cover gasket for older model pumps. Do not use gasket with O-ring end cover seal.

† Screw Kit contains 7 each #10-32 x 3/8" pan. hd. mach. screws and 1 each #10-32 x 5/16" pan. hd. mach. screw. The 5/16" screw is used only with a half thickness cam.

DISASSEMBLY

1. Remove end cover screws, end cover and O-ring.
2. Remove impeller by grasping hub with water pump pliers.
3. Loosen cam screw and remove cam (clean off sealant).
4. Remove pulley or coupling and key from shaft.
5. Remove retaining ring which secures bearing shaft assembly to pump body.
6. From impeller end of pump, press bearing and shaft assembly out of bearing bore. Remove slinger from shaft.
7. From drive end of pump, press the seal out of the seal bore.
8. If bearings or shaft need to be replaced, carefully insert two equal size slot screwdrivers between bearings 180 apart. Simultaneously twist screwdrivers in opposite directions to separate bearings. Continue to push bearings off of shaft taking care not to damage bearings or scratch shaft.
9. Remove snap ring that positions the bearings on the shaft.

NOTE: Inspect all parts for wear or damage and replace where necessary.

ASSEMBLY

1. Install bearing positioning snap ring on shaft.
2. Press bearings (one from each end of shaft) onto shaft and against positioning snap ring. Slide slinger onto impeller end of the shaft and position against raised shoulder near bearings.
3. Press seal (with lip pointing toward impeller bore) into seal bore in pump body. Ensure it is seated in bottom of seal bore. Lubricate seal lip with a small amount of grease.
4. Align impeller end of shaft with the seal and press shaft/bearing assembly into the bearing bore (push on bearing outer race). Install bearing retaining ring in retaining ring groove With concave side facing out toward drive end of shaft.
5. Apply a thin layer of sealant to screw threads and top of cam and install in body. Secure with cam screw.
6. Lubricate impeller bore with light coat of water pump grease and start impeller into bore with a rotary motion, until impeller screw engages slot in shaft, then push into bore.
7. Install O-ring and end cover. Secure with end cover screws.

DIMENSIONAL DRAWING

Inches (Millimeters)

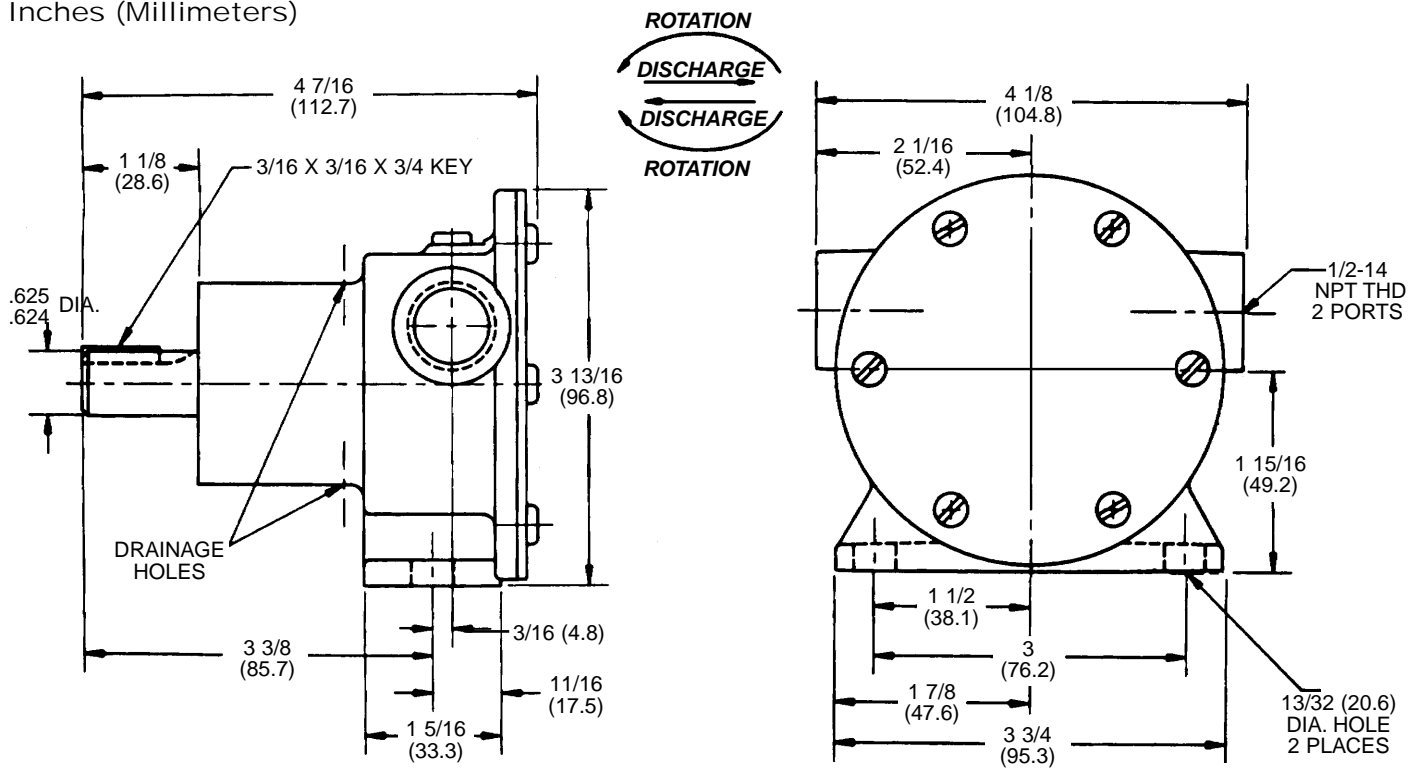

HEAD CAPACITY TABLES 1673-1001 NEOPRENE

TOTAL HEAD		500 RPM		1160 RPM		1750 RPM		2100 RPM		2450 RPM		2750 RPM		3000 RPM		3600 RPM	
P.S.I. (kPa)	Ft. of Water (metre)	GPM (L/min)	HP	GPM (L/min)	HP	GPM (L/min)	HP	GPM (L/min)	HP	GPM (L/min)	HP	GPM (L/min)	HP	GPM (L/min)	HP	GPM (L/min)	HP
4.3 (29.7)	10 (3)	3.0 (11.3)	1/6	7.6 (28.7)	1/4	11.0 (41.6)	1/4	13.0 (49.2)	1/3	15.2 (57.5)	1/2	16.7 (63.2)	1/2	18.0 (68.1)	1/2	19.6 (74.2)	3/4
8.7 (60.0)	20 (6)	1/8 (6.8)	1/6	6.4 (24.2)	1/4	10.0 (37.8)	1/4	11.5 (43.5)	1/3	13.7 (51.8)	1/2	15.4 (58.3)	1/2	17.0 (64.3)	1/2	18.8 (71.1)	3/4
13.0 (89.7)	30 (9)	-	-	4.8 (18.2)	1/4	8.5 (32.2)	1/3	10.0 (37.8)	1/2	12.0 (45.4)	1/2	13.6 (51.5)	3/4	15.3 (57.9)	3/4	17.5 (66.2)	3/4
17.3 (119.4)	40 (12)	-	-	3.3 (12.5)	1/4	6.7 (25.3)	1/3	8.5 (32.2)	1/2	10.4 (39.3)	1/2	12.0 (45.4)	3/4	13.5 (51.1)	3/4	16.0 (60.5)	1
21.6 (149.0)	50 (15)	-	-	-	-	5.0 (18.9)	1/2	6.7 (25.3)	1/2	8.5 (32.2)	3/4	10.0 (37.8)	3/4	11.8 (44.6)	3/4	14.5 (54.9)	1
26.0 (179.4)	60 (18)	-	-	-	-	-	-	5.0 (18.9)	1/2	7.0 (26.5)	3/4	8.3 (31.4)	3/4	10.0 (37.8)	3/4	13.0 (49.2)	1
30.3 (209.1)	70 (21)	-	-	-	-	-	-	-	-	-	-	6.5 (24.6)	3/4	8.0 (30.3)	1	11.0 (41.6)	1

1673-1003 NITRILE

TOTAL HEAD		500 RPM		1160 RPM		1750 RPM		2100 RPM		2450 RPM		2750 RPM		3000 RPM		3600 RPM	
P.S.I. (kPa)	Ft. of Water (metre)	GPM (L/min)	HP	GPM (L/min)	HP	GPM (L/min)	HP	GPM (L/min)	HP	GPM (L/min)	HP	GPM (L/min)	HP	GPM (L/min)	HP	GPM (L/min)	HP
4.3 (29.7)	10 (3)	2.2 (8.3)	1/6	5.8 (21.9)	1/4	9.5 (35.9)	1/4	11.5 (43.5)	1/3	13.3 (50.3)	1/2	15.0 (56.8)	1/2	16.0 (60.5)	1/2	18.2 (68.9)	3/4
8.7 (60.0)	20 (6)	-	-	4.3 (16.3)	1/4	7.6 (28.7)	1/3	9.4 (35.6)	1/3	11.4 (43.1)	1/2	13.0 (49.2)	1/2	14.4 (54.5)	1/2	17.0 (64.3)	3/4
13.0 (89.7)	30 (9)	-	-	2.5 (9.4)	1/4	6.0 (22.7)	1/3	7.4 (28.0)	1/2	9.3 (35.2)	1/2	11.0 (41.6)	1/2	12.6 (47.7)	3/4	15.3 (57.9)	3/4
17.3 (119.4)	40 (12)	-	-	-	-	4.2 (15.9)	1/2	5.6 (21.2)	1/2	7.5 (28.4)	1/2	9.2 (34.8)	3/4	10.8 (40.9)	3/4	13.6 (51.5)	1
21.6 (149.0)	50 (15)	-	-	-	-	-	-	3.9 (14.7)	1/2	5.7 (21.6)	3/4	7.2 (27.2)	3/4	9.0 (34.0)	3/4	11.7 (42.3)	1
26.0 (179.4)	60 (18)	-	-	-	-	-	-	-	-	-	-	5.5 (20.8)	3/4	7.1 (26.9)	3/4	9.7 (36.7)	1

1673-1051 HALFCAM NEOPRENE

TOTAL HEAD		500 RPM		1160 RPM		1750 RPM		2100 RPM		2450 RPM		2750 RPM		3000 RPM		3600 RPM	
P.S.I. (kPa)	Ft. of Water (metre)	GPM (L/min)	HP	GPM (L/min)	HP	GPM (L/min)	HP	GPM (L/min)	HP	GPM (L/min)	HP	GPM (L/min)	HP	GPM (L/min)	HP	GPM (L/min)	HP
4.3 (29.7)	10 (3)	1.6 (6.1)	1/6	4.1 (15.5)	1/6	6.3 (23.8)	1/4	7.7 (29.1)	1/3	9.0 (34.0)	1/3	10.1 (38.2)	1/2	11.0 (41.6)	1/2	13.1 (49.6)	3/4
8.7 (60.0)	20 (6)	1.2 (4.5)	1/6	3.6 (13.6)	1/6	5.8 (22.0)	1/4	7.0 (26.5)	1/3	8.4 (31.8)	1/2	9.5 (35.9)	1/2	10.2 (38.6)	1/2	12.3 (46.5)	3/4
13.0 (89.7)	30 (9)	-	-	3.1 (11.7)	1/6	5.0 (18.9)	1/3	6.2 (23.4)	1/3	7.6 (28.7)	1/2	8.6 (32.5)	1/2	9.4 (35.6)	3/4	11.3 (42.8)	3/4
17.3 (119.4)	40 (12)	-	-	2.4 (9.1)	1/6	4.1 (15.5)	1/3	5.3 (20.0)	1/2	6.7 (25.3)	1/2	7.7 (29.1)	3/4	8.9 (31.8)	3/4	10.3 (39.0)	3/4
21.6 (149.0)	50 (15)	-	-	-	-	3.1 (11.7)	1/3	4.2 (15.9)	1/2	5.7 (21.5)	1/2	6.7 (25.3)	3/4	7.4 (28.0)	3/4	9.2 (34.8)	3/4
26.0 (179.4)	60 (18)	-	-	-	-	-	-	-	-	4.5 (17.0)	1/2	5.6 (21.2)	3/4	6.3 (23.8)	3/4	8.1 (30.6)	3/4

Note: Progressively longer life may be expected as operating pressures and speeds are reduced. Factory Application Engineering assistance suggested for operation in light area and recommended for heavy shaded area Capacitor type motor recommended. Table shows approximate Head-Flow for new pump in US gallons (and liters) per minute.

Jabsco



ITT Industries
Engineered for life

THE PRODUCTS DESCRIBED HEREIN ARE SUBJECT TO THE JABSCO ONE YEAR LIMITED WARRANTY, WHICH IS AVAILABLE FOR YOUR INSPECTION UPON REQUEST.

U.S.A.
Jabsco
20 Icon
Foothill Ranch, CA 92610-3000
Tel: 949.609.5106
Fax: 949.859.1254

UNITED KINGDOM
Jabsco
Bingley Road, Hoddesdon
Hertfordsire EN11 OBU
Tel: +44 (0) 1992 450145
Fax: +44 (0) 1992 467132

CANADA
Fluid Products Canada
55 Royal Road
Guelph, Ontario N1H 1T1
Tel: (519) 821.1900
Fax: (519) 821.2569

JAPAN
NHK Jabsco Company Ltd.
3-21-10, Shin-Yokohama
Kohoku-Ku, Yokohama, 222
Tel: 045.475.8906
Fax: 045.475.8908

GERMANY
Jabsco GmbH
Oststrasse 28
22840 Norderstedt
Tel: +49-40-53 43 73 -0
Fax: +49-40-53 53 73 -11