

**JABSCO**[®]

Model 16510-SERIES

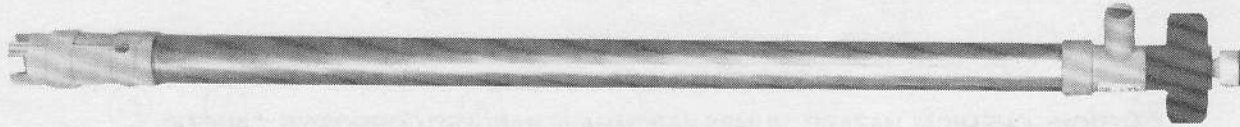

Model 16510-Series

SANITARY DRUM PUMPS

FEATURES

- Tube:** Stainless Steel and FDA Grade Polypropylene
- Impeller:** Centrifugal Type
- Shaft:** 316 Stainless Steel
- Seal:** Sealless with Viton* Vapor Barrier
- Port:** 1 inch Dia. Slip-on Hose Discharge
- Weight:** 7.5 lbs. (3,4 kgs.) average for 16510-series

VARIATIONS AVAILABLE

MODEL NO.	DESCRIPTION
16510-3270	27" (68cm) long, stainless steel
-3350	35-1/2" (90cm) long, stainless steel
-3400	40" (102cm) long, stainless steel
-3470	47" (119cm) long, stainless steel

APPLICATIONS

Designed for emptying containers, carboys, drums, and vats. Easily handles most food products. USDA approved.

 **WARNING**

WARNING: DO NOT USE SANITARY PUMPS FOR PUMPING FLAMMABLE OR EXPLOSIVE LIQUIDS OR IN A HAZARDOUS ENVIRONMENT. IF WARNING IS IGNORED, EXPLOSION CAUSING PROPERTY DAMAGE, SEVERE PERSONAL INJURY OR DEATH MAY OCCUR.

Refer to paragraph 10 of the Operating Instructions section for further information. Refer to the Chemical Resistance Table in the JABSCO Industrial Catalog (form 43001-0075) for assistance in selecting the most suitable pump material. The catalog is available upon request from ITT Jabsco.

OPERATING INSTRUCTIONS

1. **General** - When operating the JABSCO drum pump protective clothing, gloves, and safety glasses should be worn. All standard safety practices should be followed.
2. **Installation** - Pump may be mounted through bung hole in drums, on side of vats and tanks, and through top of carboys. Barrel Adaptors are available to hold pump in stationary or rigid position. Use JABSCO part no. 18753-0080. When inserting drum pump into barrel, vat or drum slowly lower pump into container to avoid spills. Correct pump length should be selected for container with which pump is to be used.
3. **Drive** - An electric motor (16420-series) and an air motor (16440-0000) are available to drive the drum pump. Both readily fit on the drive end of the pump. Refer to the motor data sheets for details (forms 43000-0468 and 43000-0469).
4. **Running Dry** - Unit has been designed for limited run dry capacity. Do not run dry for more than 30 minutes. Lack of liquid will eventually damage bearings and other pump parts.
5. **Discharge Line** - A 1" dia. barbed hose fitting has been provided on the drum pump. A tightly secured hose clamp must be used to hold the discharge hose on the discharge fitting. It is recommended that smooth bore hose of a material compatible with the fluid pumped be used as a discharge hose. Adequately secure discharge end of hose to prevent hose from whipping when pump is started.
6. **NOTICE** - When corrosive fluids are handled, pump life will be prolonged if pump is flushed with a neutralizing solution after each work day. For further information, consult JABSCO Chemical Resistance Table (available upon request from ITT JABSCO) or factory.
7. **Pressures** - The drum pump is designed to operate in containers open to the atmosphere, therefore maximum inlet pressure is atmospheric pressure (0 psig, 0 bar). For higher inlet pressure applications consult factory.
8. **Temperatures** - Sanitary pumps are suitable for service at 32° - 200°F (0° - 93°C).
9. **Storage** - When not in use store drum pump on wall bracket with impeller end in down position to allow full drainage. Use JABSCO part no. 16470-0000.
10. **Static Charge** - Certain fluids when pumped create a static electrical charge. Use only JABSCO 16410-Series pump tubes for these applications.

Viton* is a trademark of E.I. DuPont de Nemours and Company.

11. **Flow Regulation** - In applications such as filling small containers where low flow rates are required to avoid splashing of liquid an adjustable nozzle is available. Use JABSCO part no. 18753-0077.
12. **Dirt and Abrasive Particles** - It is strongly recommended that when pumping any materials containing dirt or abrasive particles a strainer be used. Strainers are available as an option. Use JABSCO part no. 16490-1000.
13. **Performance Limits** - A maximum specific gravity of 1.8 or viscosity of 3500 ssu (750 cp) is the recommended limit for normal use. Contact factory for further information.
14. **Spare Parts** - Use JABSCO service parts for replacement and repair.

SERVICE INSTRUCTIONS

CAUTION: CHEMICAL HAZARD. PUMPS WHICH HAVE HANDLED CORROSIVE, CAUSTIC OR TOXIC FLUIDS SHOULD BE DRAINED AND COMPLETELY FLUSHED PRIOR TO SERVICING. FAILURE TO DO SO MAY CAUSE INJURY.

Disassembly

1. Unscrew and remove impeller housing.
2. Insert a screwdriver through the drive coupling into the slot provided on the bearing shaft. While preventing the bearing shaft from rotating with the screwdriver, use the four pegs on bottom of the impeller housing as a wrench and unscrew and remove the impeller. This is a right-hand thread connection as are all connections on the JABSCO drum pump.
3. Unscrew and remove the conversion chamber.
4. Unscrew and remove the outer tube.
5. Remove the shaft by inserting a screwdriver through the drive coupling into the slot on the bearing shaft and rotating the bearing shaft counterclockwise while holding shaft.
6. Unscrew and remove the inner tube from the discharge port housing.
7. Gently pull the insert tube from the inner tube.
8. Unscrew and remove the discharge port housing.
9. Remove the retaining ring from the mounting ring.
10. Slip mounting ring from bearing housing.
11. Remove motor coupling from bearing shaft by inserting screwdriver into slot of bearing shaft and rotating coupling counterclockwise.
12. Remove bearing retaining ring from bearing housing.
13. Pull bearing shaft and bearings from bearing housing.
14. Press bearings off shaft.

Assembly

1. Press bearings on bearing shaft.
2. Insert bearing shaft and bearings into bearing housing.
3. Install bearing retaining into bearing housing.
4. Screw motor coupling onto bearing shaft while holding shaft from rotating with screwdriver in the slot provided. This is a right-hand thread connection as are all connections on the JABSCO drum pump.
5. Slip mounting ring on bearing housing.
6. Insert retaining ring into mounting ring.
7. Screw discharge port housing to bearing housing taking care that lip seal is positioned correctly on bearing shaft, and not damaged during assembly.
8. Install insert tube into inner tube.
9. Screw inner tube to discharge port housing.
10. Slide shaft up center of insert tube and screw into bearing shaft by turning bearing shaft with screwdriver while holding shaft.
11. Screw outer tube into discharge port housing.
12. Screw the conversion chamber to the outer tube.
13. Install impeller onto shaft and tighten using the four pegs on the impeller housing as a wrench while holding shaft from rotating with a screwdriver in the slot provided.
14. Screw impeller housing to conversion chamber. Do not operate pump without impeller housing installed.

EXPLODED VIEW

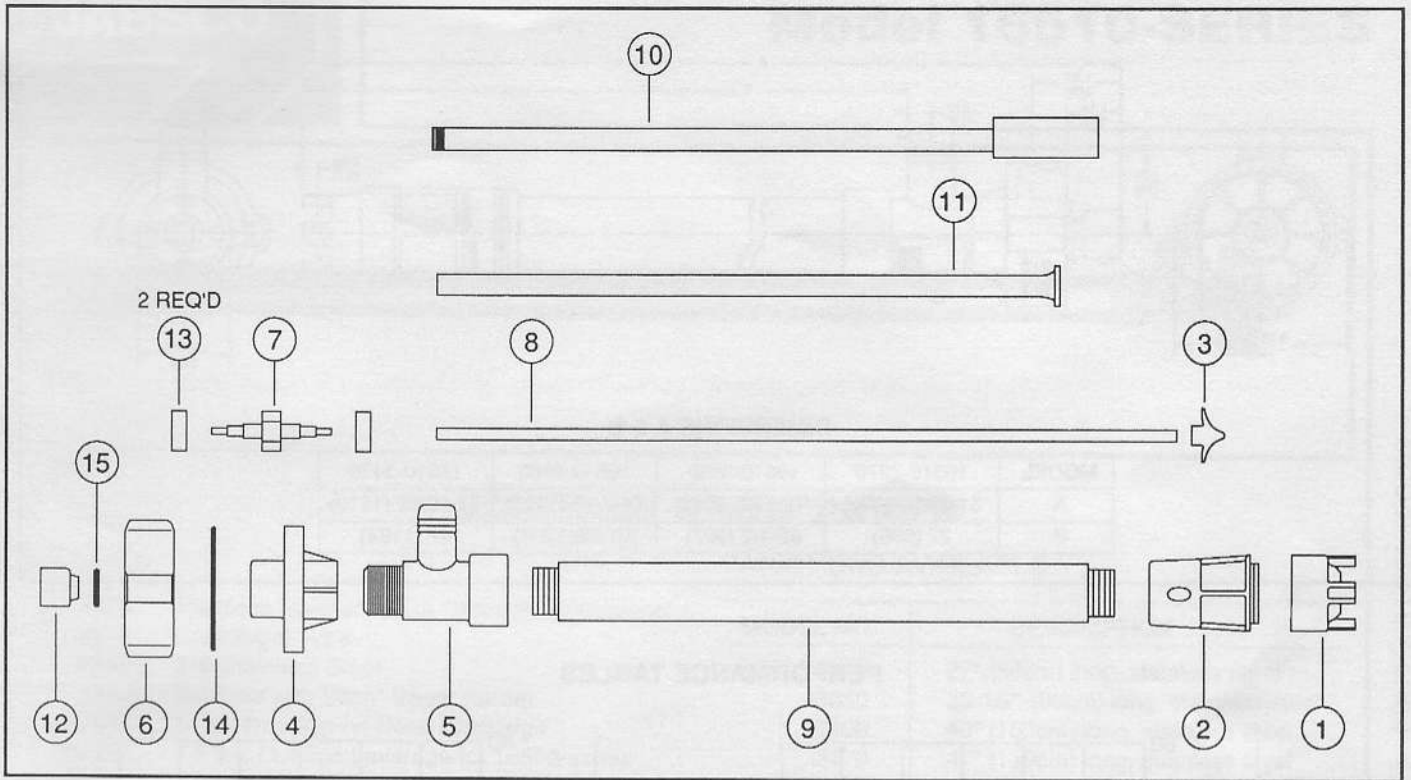

PARTS LIST

KEY	DESCRIPTION	QTY. REQ'D	MODEL 16510-3270	MODEL 16510-3350	MODEL 16510-3400	MODEL 16510-3470
1	Impeller Housing	1	16406-1002	16406-1002	16406-1002	16406-1002
2	Conversion Chamber	1	16407-1012	16407-1012	16407-1012	16407-1012
3	Impeller	1	16508-1001	16508-1001	16508-1001	16508-1001
4	Bearing Housing	1	16403-0010	16403-0010	16403-0010	16403-0010
5	Discharge Port Housing*	1	16503-1002	16503-1002	16503-1002	16503-1002
6	Mounting Ring	1	16409-0000	16409-0000	16409-0000	16409-0000
7	Bearing Shaft**	1	16468-0002	16468-0002	16468-0002	16468-0002
8	Shaft	1	16418-1006	16418-1007	16418-1011	16418-1008
9	Outer Tube	1	16461-0000	16461-0001	16461-0003	16461-0002
10	Inner Tube	1	16462-1000	16462-1001	16462-1003	16462-1002
11	Insert Tube	1	16463-0000	16463-0001	16463-0003	16463-0002
12	Drive Coupling	1	18753-0445	18753-0445	18753-0445	18753-0445
13	Bearing**	2	18753-0182	18753-0182	18753-0182	18753-0182
14	Retaining Ring	1	91701-4446	91701-4446	91701-4446	91701-4446
15	Retaining Ring	1	91701-4434	91701-4434	91701-4434	91701-4434

* Vapor Barrier is available as a kit, part no. 18753-0435.

** Shaft/Bearing Assembly is available as a kit, part no. 18753-0316.

DIMENSION DRAWING
INCHES (MILLIMETRES)

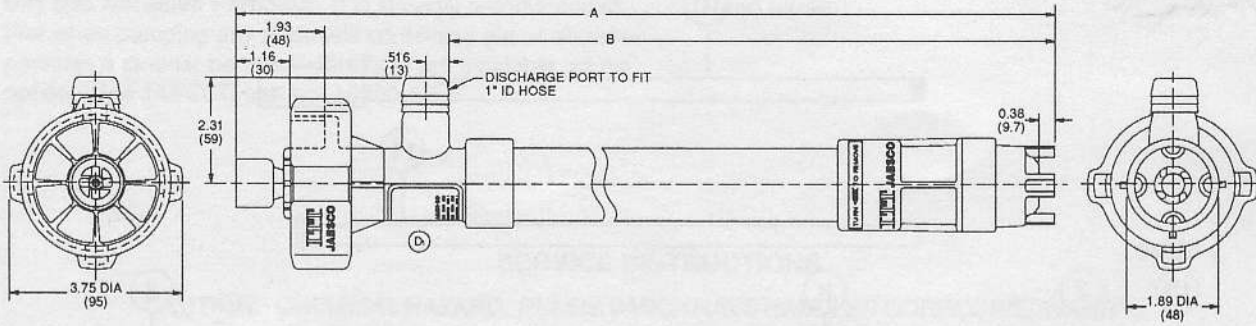

DIMENSIONS A & B

MODEL	16510-3270	16510-3350	16510-3400	16510-3470
A	31-19/32 (802)	40-3/32 (1018)	44-7/32 (1123)	51-19/32 (1310)
B	27 (686)	35-1/2 (902)	39-5/8(1006)	47 (1194)

PERFORMANCE TABLES

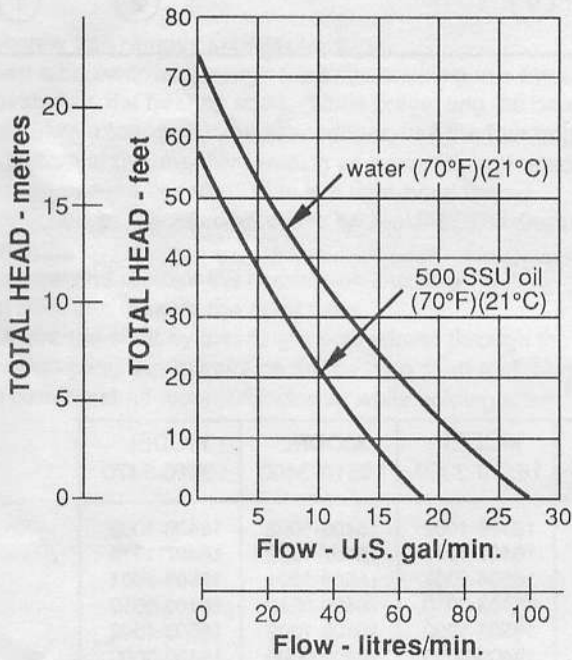

Pump tube with electric motor.

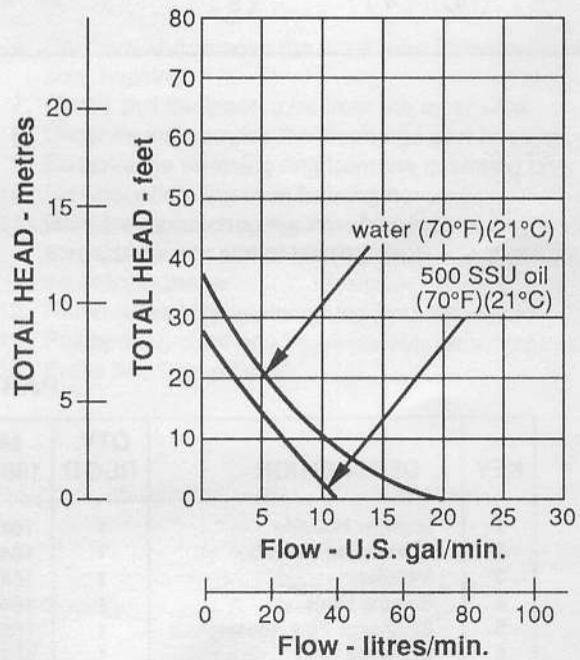

**Pump tube with air motor
operating at 80 psi (5.5 bar)
inlet air pressure to motor.**

THE PRODUCTS DESCRIBED HEREIN ARE SUBJECT TO THE JABSCO ONE YEAR LIMITED WARRANTY, WHICH IS AVAILABLE FOR YOUR INSPECTION UPON REQUEST.

ITT Jabsco
ITT Fluid Technology Corporation

1485 Dale Way, P.O. Box 2185, Costa Mesa, CA 92628-2158
Tel: (714) 545-8251; Fax: (714) 957-0609
Bingley Road, Hoddesdon, Hertfordshire EN11 0BU England
Tel: 0992-467191; Tlx: 263251 G; Fax: 0992-467132