

JABSCO PUMPS PUREFLO® SANITARY

MODEL 15570 SERIES 25 GPM Sanitary Motor Pump

MODEL 15570 SERIES PUREFLO MPU

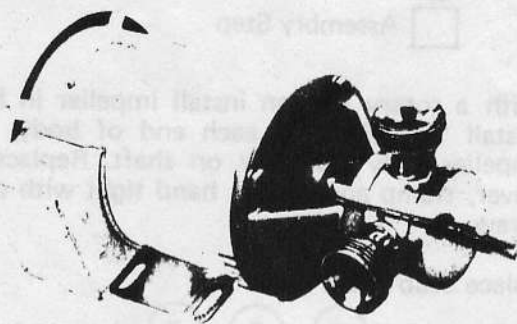

DESIGN FEATURES

Body: Type 316 Stainless Steel.
 Impeller: Jabasco Neoprene Compound.
 Seal: Sanitary Rotary Carbon Face.
 Ports: 1-1/2" Acme Sanitary Threads.
 Ground Seat.
 Motor: 2 HP, 1750 RPM, Frame K145T
 208-230-460/3/60 TEFC NEMA C Face.

VARIATIONS AVAILABLE

DESCRIPTION	MOTOR PUMP UNIT	PUMP HEAD ONLY
Neoprene Impeller – Clean-in-Place Ports	15570-0765	15570-1765
Nitrile Impeller – Acme Ports	15570-0663	15570-1663
Nitrile Impeller – Clean-in-Place Ports	15570-0763	15570-1763
Hi Pressure Neo. Imp. – Acme Ports	15570-0675	15570-1675
Hi Pressure Neo. Imp. – Clean-in-Place Ports	15570-0775	15570-1775

Note: For other than offered electrical characteristics pump head only may be installed on any K145T frame size, NEMA 'C' face motor.

APPLICATIONS AND OPERATING INSTRUCTIONS.

Some of the many diverse products handled by Jabasco Pureflo pumps include: DAIRY PROCESSING Buttermilk, Condensed Milk, Cream, Milk, Eggs, Whey and other assorted dairy products. FOOD PROCESSING Sugar Liquors, Brines, Catsup, Chocolate, Glaze, Gelatin, Honey, Jams, Jellies, Mayonnaise, Molasses, Mustard, Pickle Relish, Vinegar, Water, Yeast Slurries. BEVERAGE PROCESSING Alcohols, Beers, Brewery Slop, Cider, Distillery Wort, Extracts, Flavors, Juices, Mash, Soft Drinks, Wines. MISCELLANEOUS Chemicals, Cosmetics, Pharmaceuticals.

Jabasco Pureflo Motor Pump Units will pump fluids to the viscosity range of 500 SSU. Fluids with a

higher viscosity range should be handled with a Pedestal Mount Pureflo Pump operating at reduced speeds.

1. INSTALLATION – Pump may be mounted in any position. Pump head rotates 360° to permit desired port location. Intake and discharge ports are determined by the direction of shaft rotation. Looking at end cover with clockwise rotation, inlet ports is on horizontal right, with left port vertical.
2. SELF-PRIMING – Pump will produce 15 feet of vertical suction lift when dry and 22 feet of lift when wetted. INTAKE LINES MUST BE AIR-TIGHT to prevent product foaming and assure self-priming.

3. RUNNING DRY – The impeller is lubricated by the product being pumped. DO NOT RUN DRY for more than 30 seconds. Lack of liquid may damage the impeller.
4. TEMPERATURES – 40°–150°F. Contact factory for impeller recommendation on applications outside this range. Other impeller compounds are available which may be utilized for certain applications at higher or lower temperatures.
5. PRESSURES – Consult performance chart. When operating pressures approach the upper recommended ranges for standard pressure impellers, it is ordinarily desirable to use a high pressure model to increase impeller life.

SERVICE INSTRUCTIONS

- Disassembly Step
 Assembly Step

To Replace Impeller

- ① Loosen clamp screw. Remove clamp, end cover and "O" ring gasket.
- ② Grasp hub of impeller with water pump pliers and withdraw from body.
- ③ Wipe a thin film of Petrogel, or equal, lubricant in impeller bore. With a clockwise rotary motion, start impeller into bore until impeller drive engages shaft flats. Push impeller into body.
- ④ Install "O" ring on body. Install end cover and clamp and tighten clamp screw. Do not overtighten.

To Replace Seal

- ⑤ Remove piping fittings from ports. Loosen clamp screw. Remove clamp, end cover and body (body will contain impeller and both "O" ring gaskets). Check impeller, replace if necessary.
- ⑥ Remove wear plate from adaptor bore (it may be necessary to tap wear plate gently from seal side).
- ⑦ Grasp seal with fingers (do not use pliers or carbon may be damaged) and withdraw from adaptor housing. It may be necessary to pry gently between seal and collar to help remove seal.
- ⑧ Loosen two set screws in collar, but do not remove collar.
- ⑨ Dip seal in water and slide over shaft with carbon facing outward.
- ⑩ Install wear plate in adaptor with seal boss outward (this is intentionally *backwards*). Hold wear plate firmly against adaptor shoulder and push carbon seal face firmly against wear plate. Slide collar forward against seal and secure on shaft with two set screws. Remove wear plate and reinstall it with seal boss against carbon face of seal. When pump is fully assembled, the seal will have the correct compression for long seal life. Be sure that wear plate seal boss is not heavily worn. A new seal and a worn wear plate seal face is not compatible!

- ⑪ With a rotary motion install impeller in body. Install "O" rings on each end of body. Slide impeller/body assembly on shaft. Replace end cover, clamp and secure, hand tight with clamp screw.

To Replace Stub Shaft

- ⑫ Follow steps ⑤, ⑥, ⑦. Loosen two set screws in collar and remove collar from shaft. Loosen four set screws in stub shaft and pull stub shaft from motor shaft. Check shaft key for wear and replace if necessary. **Note:** This step may be accomplished more easily if adaptor is removed from motor first.
- ⑬ Install key in motor shaft. Slide stub shaft over motor shaft until it bottoms firmly. Tighten four set screws to secure stub shaft to motor shaft. (Install adaptor to motor if new assembly, or if adaptor was removed when replacing stub shaft.)
- ⑭ Slide collar onto stub shaft, with counterbore facing outwards. Do not tighten set screws until seal has been correctly positioned.
- ⑮ Follow steps ⑨, ⑩, and ⑪ to complete assembly.

COMPLETE PUMP HEAD FITS K145TC
FRAME ELECTRIC MOTOR (NEMA "C"
FACE)

MODEL 15570 SERIES
DIMENSIONAL DRAWING
(MILLIMETERS)

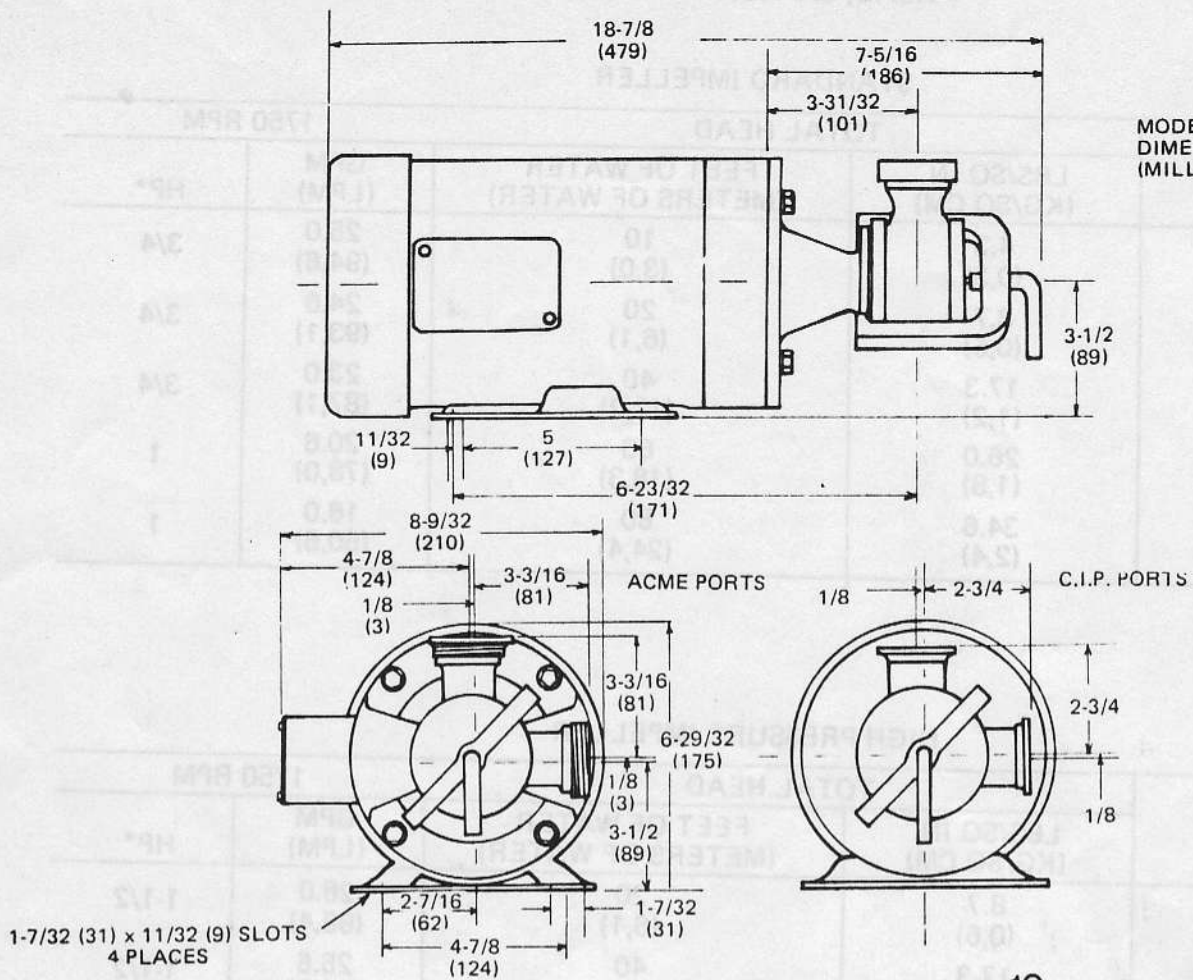

1-7/32 (31) x 11/32 (9) SLOTS
4 PLACES

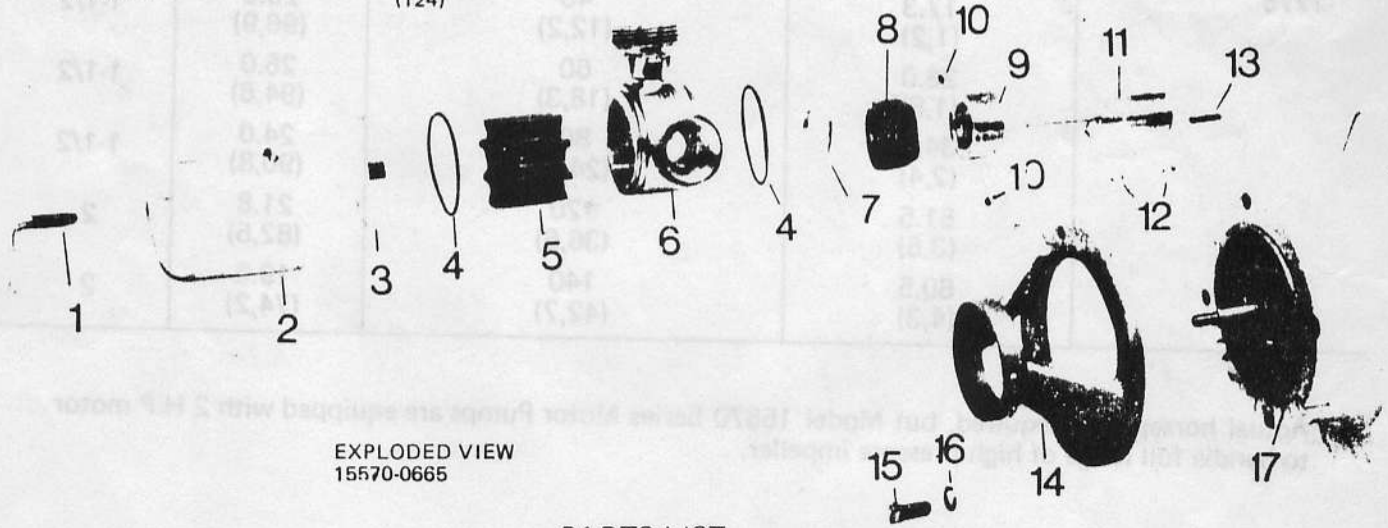

EXPLODED VIEW
15570-0665

PARTS LIST

KEY	DESCRIPTION	PART NO.	QTY	KEY	DESCRIPTION	PART NO.	QTY
1	Clamp Screw	9551-0010	1	9	Collar includes	15579-0000	1
2	Clamp	12698-0000	1	10	Set Screw	91084-0335	2
3	End Cover	10515-0001	1	11	Stub Shaft includes	15578-0000	1
4	'O' Ring (Body)	92000-0310	2	12	Set Screw	91084-0336	4
5	Impeller — Neoprene	8981-0005	1	3	Key	91402-0291	1
	— Nitrile	8840-0006		14	Adapter	14034-0000	1
	— Hi Pres. Neo.	8840-0005		15	Bolt	91094-0070	4
6	Body — Acme Ports	15034-0061	1	16	Washer	91602-0090	4
	— C.I.P. Ports	15034-0071		17	Motor 2 HP 1750 RPM	93004-2612	1
7	Wear Plate	10046-0010	1		208-230-460/3/60		
8	Seal	8728-0000	1		K145TC Frame		

STANDARD IMPELLER

MODEL	TOTAL HEAD		1750 RPM	
	LBS/SQ IN. (KG/SQ CM)	FEET OF WATER (METERS OF WATER)	GPM (LPM)	HP*
15570-0665, -0675, -1665, -1675 For nitrile impeller versions -0663, -0763, -1663, -1763, reduce capacity values by 10%	4.3 (0,3)	10 (3,0)	25.0 (94,6)	3/4
	8.7 (0,6)	20 (6,1)	24.6 (93,1)	3/4
	17.3 (1,2)	40 (12,2)	23.0 (87,1)	3/4
	26.0 (1,8)	60 (18,3)	20.6 (78,0)	1
	34.6 (2,4)	80 (24,4)	16.0 (60,6)	1

HIGH PRESSURE IMPELLER

MODEL	TOTAL HEAD		1750 RPM	
	LBS/SQ IN. (KG/SQ CM)	FEET OF WATER (METERS OF WATER)	GPM (LPM)	HP*
15570-0675, -0775, -0675, -1775	8.7 (0,6)	20 (6,1)	26.0 (98,4)	1-1/2
	17.3 (1,2)	40 (12,2)	25.6 (96,9)	1-1/2
	26.0 (1,8)	60 (18,3)	25.0 (94,6)	1-1/2
	34.6 (2,4)	80 (24,4)	24.0 (90,8)	1-1/2
	51.5 (3,6)	120 (36,6)	21.8 (82,5)	2
	60.5 (4,3)	140 (42,7)	19.6 (74,2)	2

*Actual horsepower required, but Model 15570 Series Motor Pumps are equipped with 2 H.P motor to handle full range of high pressure impeller.

JABSCO PRODUCTS ITT

Marine and Recreation Components Division
International Telephone and Telegraph Corporation
1485 Dale Way, Costa Mesa, California 92626
Telephone (714) 545-8251