

**JABSCO**

## Model 15173-Series

### PUREFLO® SANITARY PUMPS

#### FEATURES

Body:	Type 316 Stainless Steel
Impeller:	Jabsco Sanitary Neoprene Compound
Seal:	Sanitary Mechanical
Bearings:	Ball/Roller Bearings
Shaft:	Type 316 Stainless Steel
Ports:	2-1/2" Acme Threads
Weight:	45 lb (20.4 kg) approx.

#### VARIATIONS

MODEL	DESCRIPTION
15173-0005	Std. Pressure Impeller, ACME Ports

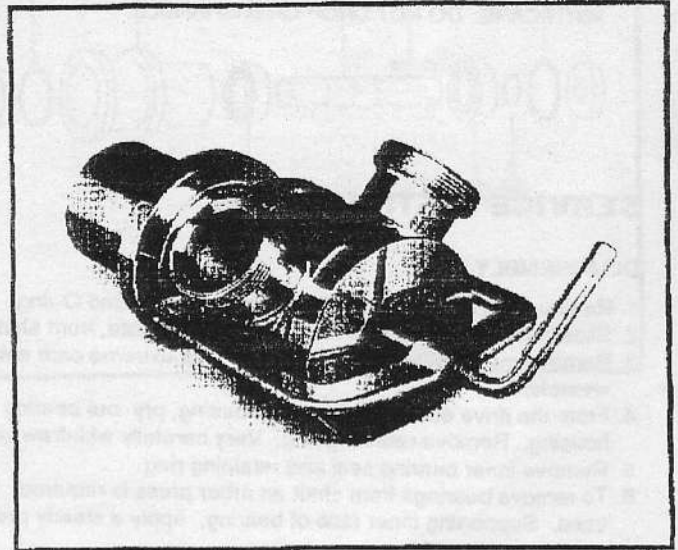

#### APPLICATIONS

This product is specifically designed for farm pick-up milk tanker trucks. PUREFLO pumps are also available as pedestal mounted or close-coupled units with capacities to 100 GPM for other sanitary applications. Contact factory for details.

#### OPERATING INSTRUCTIONS

- INSTALLATION** – Pump may be mounted in any position. The rotation of the pump shaft determines the location of the pump's intake and discharge ports. Refer to dimensional drawing. Pump is normally assembled at factory for clockwise rotation looking at end cover. If counterclockwise rotation is desired, follow steps 1 and 2 of disassembly and step 9 of assembly instructions to change direction of impeller blade deflection under cam.
- DRIVE** – Belt or direct with flexible coupling.  
Belt Drive: Overtight belt load will reduce pump bearing life.  
Direct Drive: Clearance should be left between drive shaft and pump shaft when installing coupling. Always mount and align pump and drive shaft before tightening the coupling set screw. If pulley or coupling must be pressed on shaft, remove end cover and impeller to support shaft from impeller end during press operation. Do not hammer pulley or coupling on shaft; this may damage bearing or seal.  
Capacitor start motor is required to overcome starting torque of impeller.
- SPEEDS** – 100 RPM to the maximum shown in the performance curves. For longer pump life, operate at lowest possible speeds. Lower speeds are required for viscous liquids, consult the factory for proper speeds and horsepower requirements.
- SELF-PRIMING** – Primes at low or high speeds. For vertical dry suction lift of 10 feet, a minimum of 800 RPM is required. Pump will produce suction lift up to 22 feet when wet. **BE SURE SUCTION LINES ARE AIRTIGHT OR PUMP WILL NOT SELF-PRIME.**
- DISCHARGE** – When transferring liquids further than 25 feet, use 3" discharge line.
- RUNNING DRY** – Unit depends on liquid pumped for lubrication. **DO NOT RUN DRY** for more than 30 seconds. Lack of liquid will damage the impeller.
- PUMPAGE COMPATIBILITY** – When corrosive cleaning fluids are handled, pump life will be prolonged if pump is flushed with a neutralizing solution after each use or after each work day. A Tungsten Carbide Seal variation is available for pumping liquids that contain abrasives or are highly corrosive.
- PRESSURES** – Consult Performance Curves for maximum recommended pressures for pump in continuous operation. If pressures exceed those shown, consult the factory.

**WARNING**

Exposed pulley and belts can cause injury, install shield around pulleys and belts.

9. **TEMPERATURES** – The operating temperature limits of the pump: 45° to 150° F (7° to 65° C).
10. **CLEANING** – Before using pump it should be disassembled and cleaned to remove any dust and dirt resulting from storage or shipping. Wash parts in standard cleaning solutions approved for handling stainless steel. Thoroughly rinse before reassembly. **DO NOT USE IODINE BASED SANITIZERS** as the iodine attacks the elastomer materials used in the impeller.

All parts have been expertly machined and polished. **HANDLE WITH CARE. DO NOT DROP OR MISHANDLE.**

11. **IMPELLER TORQUE** – The torque required to initiate rotation of a new impeller in a dry pump body is:  
Forward – 10.2 pounds force – feet  
Reverse – 18.8 pounds force – feet  
These values may vary slightly due to manufacturing tolerances. Consult factory for more information.
12. **SPARE PARTS** – To avoid costly shutdowns, keep a spare JABSCO impeller, seal and O-ring set on hand.

## SERVICE INSTRUCTIONS

### DISASSEMBLY

1. Remove end cover clamp. Remove end cover and O-ring.
2. Slide body, complete with impeller and wearplate, from shaft assembly. Remove impeller from body.
3. Remove mechanical seal from shaft. Use extreme care not to mar shaft surface. Remove seal seat and O-ring from recess in wearplate.
4. From the drive end of the bearing housing, pry out bearing seal by inserting a screwdriver blade between OD of the seal and housing. Remove retaining ring. Very carefully withdraw shaft and bearing assembly.
5. Remove inner bearing seal and retaining ring.
6. To remove bearings from shaft an arbor press is required. If an arbor press is not available then a bearing extractor may be used. Supporting inner race of bearing, apply a steady pressure on shaft until bearing slides free. Repeat this procedure to remove second bearing.

### ASSEMBLY

1. To replace bearing on shaft. Support bearing on its inner race and locate shaft onto bearing. Apply a steady pressure to the shaft until bearing locates against shoulder on shaft. Repeat for second bearing.
2. Fit retaining ring and bearing seal into impeller end of bearing housing. Spring on bearing seal to face outwards.
3. Apply bearing grease around and between bearings, filling cavity between bearings two thirds full. Smear grease on shaft where bearing seal locates. Push shaft and bearing assembly into bearing housing.
4. Replace the two retaining rings and outer bearing seal, with spring facing outwards, on drive end of bearing housing.
5. Replace mechanical seal by sliding positioning washer onto shaft up to locating shoulder, then smear shaft with light lubricating oil. Push on seal gently until it engages with washer. Fit O-ring and seal seat into wearplate.
6. Insert impeller in pump body. Fit O-ring on each end of the pump body. Fit wearplate to body.
7. Slide wearplate and body assembly over shaft, positioning wearplate in housing.
8. Fit end cover and end cover clamp. Clamp should be hand tightened. Do not use wrench or hammer.
9. **Changing Pump Rotation (locking at end cover):**  
Clockwise Rotation: Insert impeller into pump body with blades bending counterclockwise  
Counterclockwise Rotation: Insert impeller into pump body with blades bending clockwise.

## EXPLODED VIEW

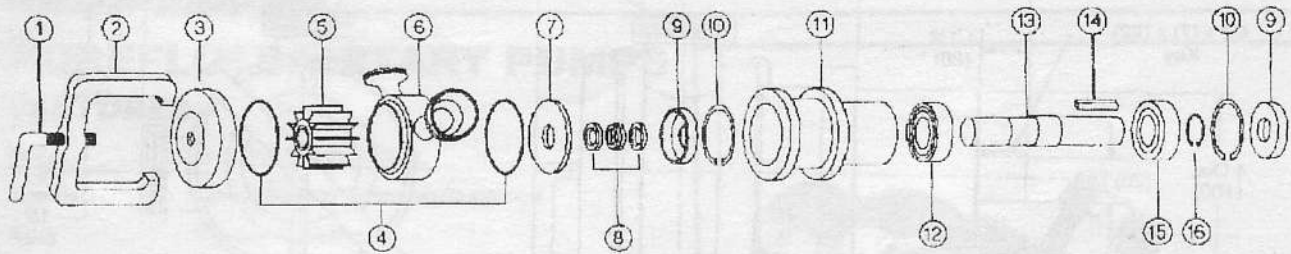

## SPARE PARTS LISTING

Key	Description	Part No.	Qty
1	Clamp Screw	18753-0473	1
2	Clamp Frame	18753-0474	1
3	End Cover	18753-0475	1
4	O-ring	18753-0476	2
5	Impeller	8500-0005	1
6	Body (Acme)	18753-0477	1
7	Wearplate	18753-0478	1
8	Seal Kit	18753-0479	1
9	Bearing Seal	18753-0482	2
10	Retaining Ring (Hsg)	18753-0483	2
11	Bearing Hsg	18753-0484	1
12	Roller Bearing (front)	18753-0481	1
13	Shaft	18753-0486	1
14	Key	18753-0487	1
15	Ball Bearing (rear)	18753-0485	1
16	Retaining Ring (shaft)	18753-0480	1

## DIMENSIONAL DRAWINGS INCHES (Millimetres)

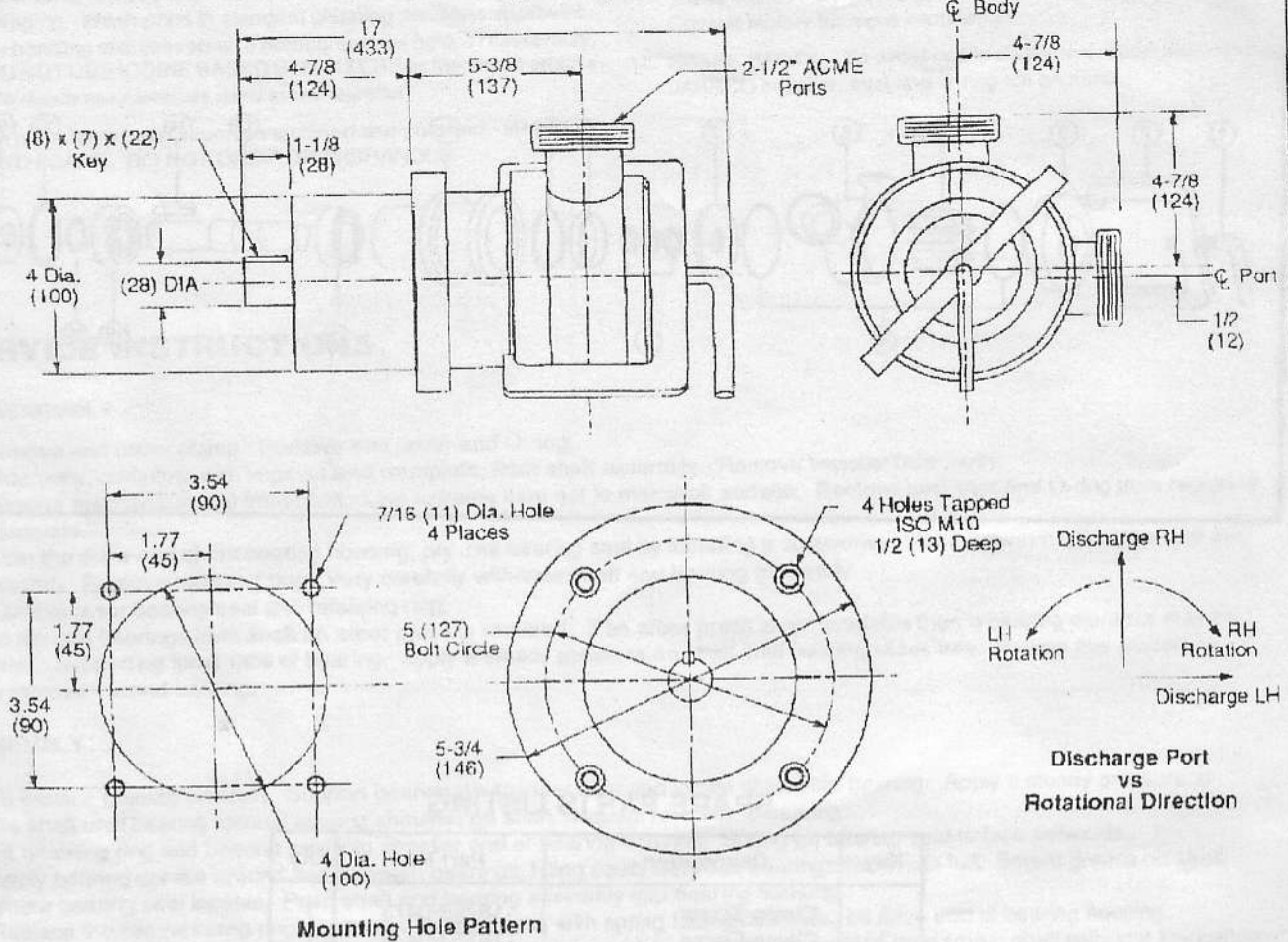

## PERFORMANCE CURVES

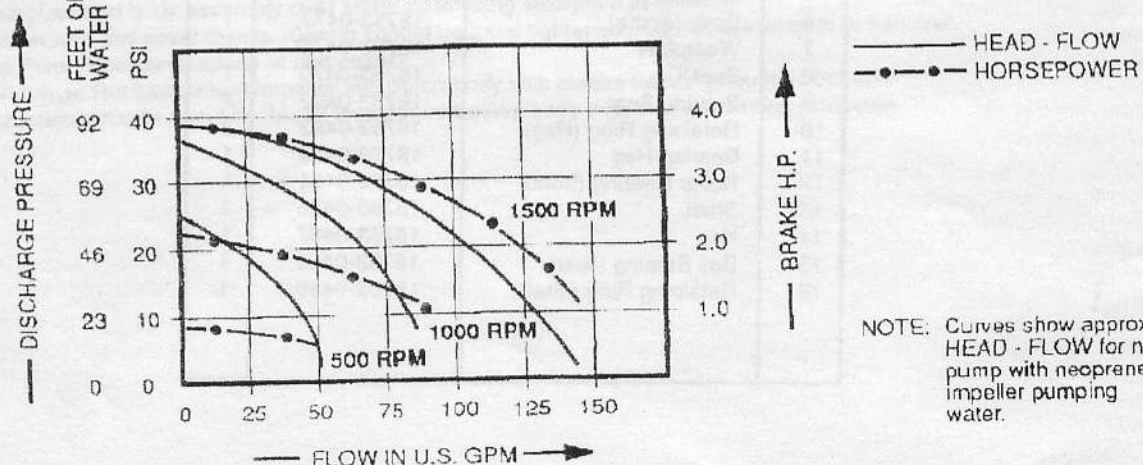

NOTE: Curves show approx. HEAD - FLOW for new pump with neoprene impeller pumping water.

THE PRODUCTS DESCRIBED HEREIN ARE SUBJECT TO THE JABSCO ONE YEAR LIMITED WARRANTY, WHICH IS AVAILABLE FOR YOUR INSPECTION UPON REQUEST.

**ITT Jabsco**

ITT Fluid Technology Corporation  
 1405 Dale Way, P.O. Box 2158, Costa Mesa, CA 92628-2158  
 Tel: (714) 545-6251; Fax: (714) 957-0809  
 Bingley Road, Hoddeston, Hertfordshire EN11 0BU England  
 Tel: 0992 467191; Tlx: 263251 G; Fax: 0992-467132