

# JABSCO® PUMPS

Self-priming Pumps

## MODELS: 14900-0001, 12310-0001

Product Data

Formerly PE1-M6, PE4-M6

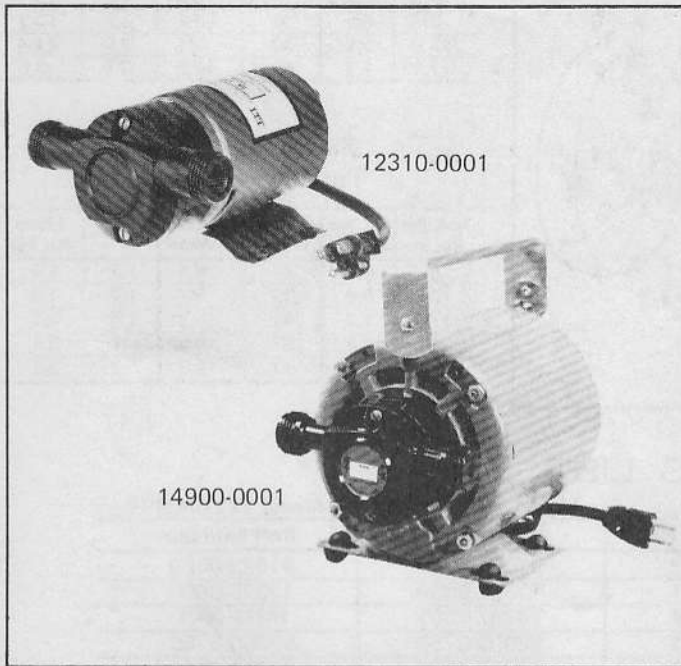

### DESIGN FEATURES

Body:	Phenolic
Impeller:	Jabscos Neoprene Compound
Shaft Seal:	Lip Type
Shaft:	Stainless Steel (Supplied in Motor)
Ports:	3/4" Garden Hose External 3/4" Pipe Thread Internal
Weight:	10 lbs. Model 14900-0001 (4,5 kg) 5 3/4 lbs. Model 12310-0001 (2.6 kg)
Motor:	115 Volt AC-Model 14900-0001 (Continuous Duty) 115 Volt AC-Model 12310-0001 (Intermittent Duty)
Variations:	14900-0003-Nit. Imp 14787-0003 12310-0003-Nit. Imp 14792-0003

MODELS: 14900-0001, 12310-0001

### APPLICATION INFORMATION

Designed as a low cost pump with improved chemical resistance for chemical feeding, transfer, circulation, filtration, metering, filling line use and similar. Handles pure solutions, foaming liquids, and thin emulsions.

Because of the chemical resistance of phenolic plastic and 316 stainless steel these pumps are widely used to pump photo chemicals, plating solutions, lab solutions, pharmaceuticals, cosmetics, weak acids, alkalies, liquid fertilizers, insecticides, dyes, detergents, waxes and many more.

Limit Model 12310-0001 to liquids with viscosity less than 50 SSU and Model 14900-0001 to viscosities of less than 500 SSU.

See the Jabscos "Chemical Resistance Table" in the Industrial Catalog which has been prepared as a guide to selection of pump material.

### OPERATING INSTRUCTIONS

- 1. INSTALLATION** — Pump may be mounted in any position. The intake is located on the right when looking at the end cover.
- 2. SELF-PRIMING** — Pump will produce suction lifts up to 10 feet when dry and to 15 feet when wetted. BE SURE SUCTION LINES ARE AIR TIGHT OR PUMP WILL NOT SELF-PRIME.
- 3. RUNNING DRY** — Unit depends on liquid pumped for lubrication. DO NOT RUN DRY FOR MORE THAN 30 SECONDS. Lack of liquid will burn the impeller and damage the plastic components.
- 4. CAUTION** — If corrosive fluids are handled, pump life will be prolonged if flushed with water after each use or after each work day. Consult JABSCO Pump Chemical Resistance Table. For further information, contact factory.
- 5. PRESSURES** — Consult Head Capacity Table for recommended maximum for continuous operation. If pressures exceed those shown, consult the factory.
- 6. TEMPERATURES** — Neoprene 45°-180°F Nitrile 50° - 180°F
- 7. SPARE PARTS** — A spare service kit should be kept on hand to eliminate excessive downtime.

# ITT JABSCO

Form 43000-0025 Rev. 6/81

## EXPLODED VIEW

## HEAD CAPACITY TABLES

### Model 12310-0001 Total Head Capacity

Lbs. per Sq. in.	Kg. per Sq. Cm	Feet of Water	Meters of Water	GPM	Liters Per Min
4.3	0,3	10	3,0	4.0	15,1
8.7	0,6	20	6,1	3.5	13,2
13.0	0,9	30	9,1	3.0	11,4
17.3	1,2	40	12,2	2.5	9,5

### Model 14900-0001 Total Head Capacity

Lbs. per Sq. in.	Kg. per Sq. Cm	Feet of Water	Meters of Water	GPM	Liters Per Min
8.7	0,6	20	6,1	1.3	4,9
13.0	0,9	30	9,1	1.2	4,5
17.3	1,2	40	12,2	1.1	4,2
21.6	1,5	50	15,2	.9	3,4
26.0	1,8	60	18,3	.7	2,6

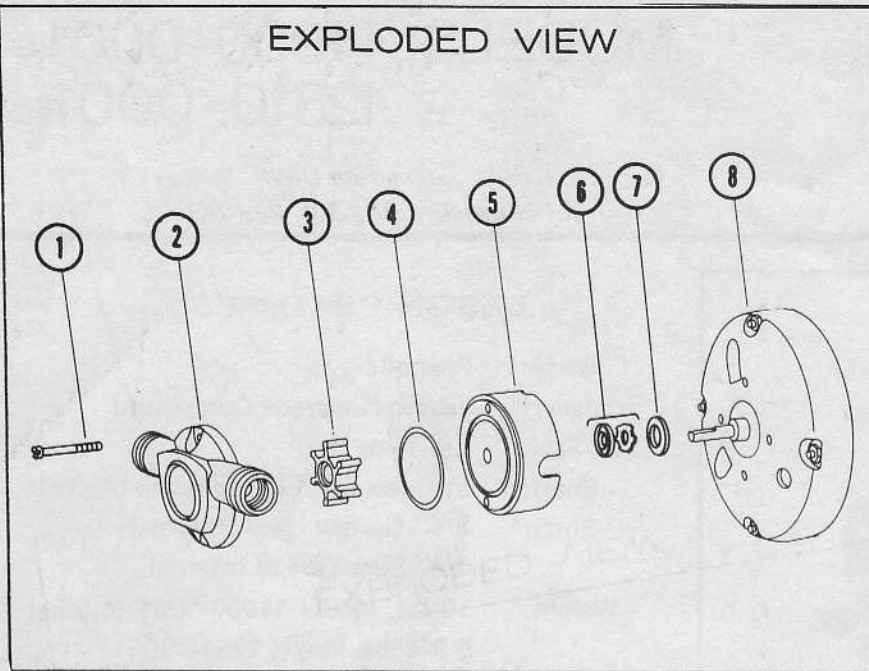

## PARTS LIST

Key	Description	Qty. Req.	Model 14900-0001	Model 12310-0001
			Part Number	Part Number
1	Screw (End Cover)	2	91023-0050	91023-0050
2	Body	1	12375-0000	12375-0000
3	*Impeller	1	14787-0001	14792-0001
4	**"O" Ring	1	92000-0750	92000-0750
5	Seal Hsg	1	12314-0000	12314-0000
6	*Seal Assy	1	1040-0000	1040-0000
7	Slinger	1		6342-0000
8	Motor	1	93004-0790	9195-0004
	Grommet	4	92900-0020	92900-0120
	Replacement Pump Head		12377-0011	12377-0001
	Service Kit Neoprene		90158-0021	90158-0011
	Service Kit Nitrile		90158-0023	90158-0033
	Brush Assembly Replacement Kit			42626-0000

\*Parts supplied in Service Kit

## DIMENSIONAL DRAWING

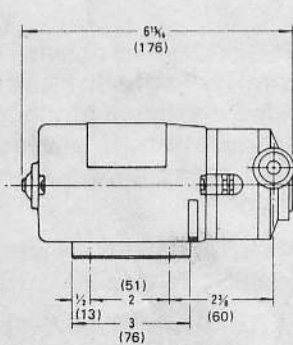

MODELS  
12310-0001  
12310-0003

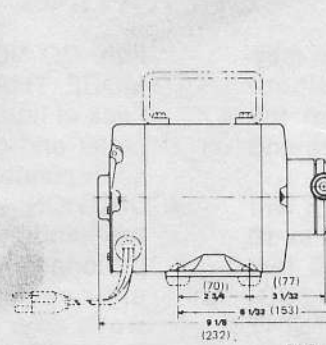
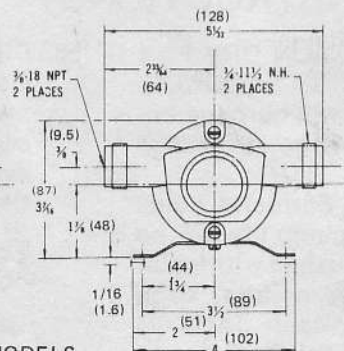

MODELS  
14900-0001  
14900-0003

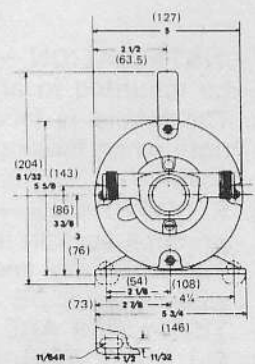

(Millimeter Equivalent)

# ITT JABSCO

MARC Division

International Telephone and Telegraph Corporation  
1485 Dale Way, Costa Mesa, California 92626

Telephone: (714) 545-8251