

# Model 12210-Series

## SELF-PRIMING PUMP

### FEATURES

- Body: Bronze
- Impeller: Jabsco Neoprene or Nitrile Compound
- Seal: Lip Type
- Motor: 115 Volt AC with Replaceable Brushes, Stainless Steel Shaft, 6' cord, three prong grounding plug
- Ports: 3/8" Internal Pipe Thread and Adaptors for 3/4" garden hose thread
- Height: 3-5/8"
- Width: 4"
- Length: 6-7/8"
- Weight: 5 lb (2.3 kg)(approx.)

### VARIATIONS AVAILABLE

MODEL NO.	DESCRIPTION
12210-0001	Neoprene Impeller
12210-0003	Nitrile (oil resistant) Impeller

### APPLICATIONS

**INDUSTRIAL:** Transferring liquids. Velocity-mixing. Pumping coolants. Pumping waste water to sewer. Cellar, yard and sump drainage. Cooling Heliarc welding equipment.

**MARINE:** Washing down decks and docks. Water for ship's service supply. Pumping out crank-case oil.

**FARMING:** Pumping water for stock, poultry houses, farmhouse. Pumping water from wells and cisterns. Pumping liquid ballast into tractor tires. Pumping water from flooded basements.

**PLUMBING AND HOME EMERGENCY USE:** Pumping out flooded basements, cesspools, sumps, etc. Draining water heaters and water closets. Draining laundry tubs below sewer level. Removing water trapped between walls, draining inaccessible places when pipes break or leak. Draining fishing ponds and garden pools. Removing sludge, lyewater and other caustics from stopped up drains and sinks.

### OPERATING INSTRUCTIONS

**WARNING** Explosion hazard. Do not use where flammable vapors are present. To do so can cause an explosion resulting in injury or death.

1. **INSTALLATION** – Pump may be mounted at any angle without loss of efficiency. Suggested mounting is horizontal or with pump head down. The inlet port is the right hand port when looking at the end cover.



**Model 12210-Series**

2. **DRIVE** – Direct.
3. **SELF-PRIMING** – Pump will produce a suction lift approaching 5 feet when dry and a lift up to 20 feet when primed. **BE SURE SUCTION LINES ARE AIRTIGHT.**
4. **RUNNING DRY** – Unit depends on liquid pumped for lubrication. **DO NOT RUN DRY** for more than 30 seconds. Lack of liquid will damage the impeller.
5. **NOTICE** – Do not pump solvents, thinners, highly concentrated or organic acids. If corrosive fluids must be handled consult Jabsco Chemical Resistance Table (available on request from ITT Jabsco). Pump life will be prolonged if pump is flushed with water after each use or after each work day.
6. **DUTY** – The “Handi-Puppy” is designed for intermittent duty in applications such as: transferring liquids; draining water heaters and water closets; pumping water from basements and other applications which require a few hours of continuous operation.
7. **TEMPERATURES** – Neoprene 45°F (7.2°C) to 180°F (82.2°C), Nitrile 50°F (10°C) to 180°F (82.2°C).
8. **FREEZING WEATHER** – Drain unit by loosening end cover plate.

### HEAD CAPACITY TABLE

PSI	FEET	GPM
4.3	10	3.4
8.7	20	3.2
13.0	30	2.9
17.4	40	2.0

Table shows approximate Head-Flow for new pump in U.S. gallons per minute.

EXPLODED VIEW

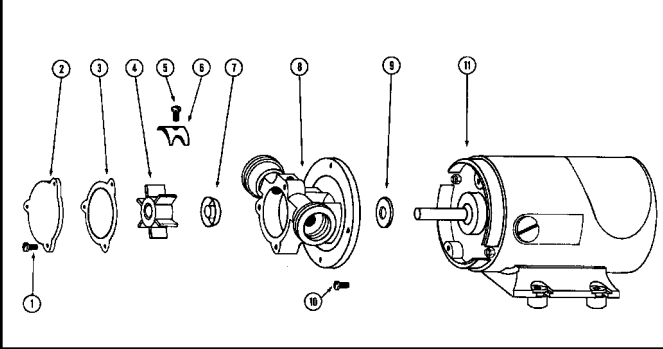

PARTS LIST

KEY	DESCRIPTION	PART NUMBER	QTY.
1	Screw - End Cover (3 per kit)	91002-0090	1
2	End Cover	12076-0000	1
3	Gasket*	7828-0000	1
4	Impeller - Neoprene*	1414-0001	1
	Nitrile	1414-0003	
5	Screw (Cam)	91002-0010	1
6	Cam	8089-0000	1
7	Seal*	93000-0100	1
8	Body	7824-0000	1
9	Slinger	6342-0000	1
10	Screw - Motor (2 per kit)	98019-0020	1
11	Motor and Base Assy.	9195-0004	1
	Replacement Pump Head	9040-0001	
	Neoprene Impeller		
	Replacement Pump Head	9040-0005	
	Nitrile Impeller		
	Service Kit, Neoprene	90092-0007	
	Service Kit, Nitrile	90092-0004	
	†Brush Repair Kit with		
	White Brush Caps	42626-0001	

\* Parts contained in Service Kit.

† Brush Kits for motors manufactured prior to 1982 with black brush caps are no longer available.

DISASSEMBLY

1. Remove end cover screws, end cover and gasket.
2. Withdraw impeller.
3. Loosen cam screw and remove cam.\*

Jabsco



U.S.A.  
Jabsco  
1485 Dale Way, P.O. Box 2158  
Costa Mesa, CA 92628-2158  
Tel: (714) 545-8251  
Fax: (714) 957-0609

UNITED KINGDOM  
Jabsco  
Bingley Road, Hoddesdon  
Hertfordshire EN11 0BU  
Tel: +44 (0) 1992 450145  
Fax: +44 (0) 1992 467132

CANADA  
Fluid Products Canada  
55 Royal Road  
Guelph, Ontario N1H 1T1  
Tel: (519) 821-1900  
Fax: (519) 821-2569

JAPAN  
NHK Jabsco Company Ltd.  
3-21-10, Shin-Yokohama  
Kohoku-Ku, Yokohama, 222  
Tel: 045-4758906  
Fax: 045-475-8908

GERMANY  
Jabsco GmbH  
Oststrasse 28  
22844 Norderstedt  
Tel: +49-40-53 53 73 -0  
Fax: +49-40-53 53 73 -11

DISASSEMBLY (Cont.)

4. Loosen and remove two slotted hex screws which attach body to motor.
5. Tap body lightly between ports and remove body from motor.
6. Remove seal from body cavity.

NOTE: Do not tamper with or disassemble motor.

ASSEMBLY

1. Lubricate seal. Install in cavity with open side of seal facing impeller.
2. Lubricate motor shaft and install body on motor.
3. Apply a dab of waterproof sealant to top of cam and reinstall and attach it with cam screw.\*
4. Lubricate impeller bore and aligning flat in impeller with flat on motor shaft, install impeller.
5. Install gasket, end cover and screws.

\*Cam removal and reinstallation required only when replacing cam.

BRUSH REPLACEMENT

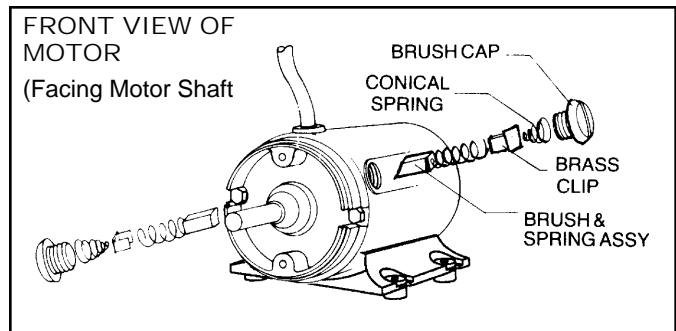

Replacement brush kit includes 2 each brush and spring assemblies, brass clips, conical springs, and caps.

Remove old brush assemblies and replace in order shown above. Make sure curvature on end of brush is pointed in direction shown.

THE PRODUCTS DESCRIBED HEREIN ARE SUBJECT TO THE JABSCO ONE YEAR LIMITED WARRANTY, WHICH IS AVAILABLE FOR YOUR INSPECTION UPON REQUEST.