

# JABSCO® PUMPS

Self-Priming Pumps

# MODEL: 12040-0001

Product Data

FORMERLY 12040 1-1/4"  
Supersedes Model 1095

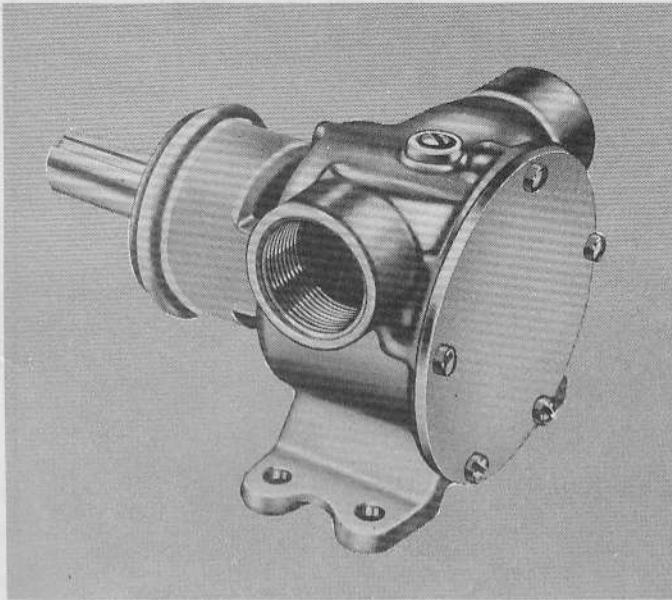

12040-0001

## DESIGN FEATURES

- Body: Cast Iron Construction
- Impeller: Jabsco Neoprene Compound
- Shaft: Steel
- Seal: Carbon-Face Rotary Type with Replaceable Stainless Steel Seal Seat
- Bearings: Sealed Ball Bearings
- Ports: 1 1/4" NPT
- Weight: 12 3/4" lbs. (approximately) (5,8 kgs)

## APPLICATION

- Circulating and transferring liquids.
- Returning spilled liquids to process.
- Chemical manufacturers and pharmaceutical houses – to pump soap, liquors, ink, dyes, medicine, alcohol, various acids, tanning liquors, lotions, glycerine.
- Circulation of abrasive slurries (low speed).
- Circulating and transferring alkaline solutions
- Inexpensive, expendable acid pump.
- Circulating and processing wood pulp slurries, fertilizer application.

MODEL: 12040-0001

## HEAD CAPACITY TABLES

Standard Pressure	TOTAL HEAD				500 RPM			1160 RPM			1450 RPM			1750 RPM		
	PSI	Kgs per sq cm	Feet of Water	Meters of Water	GPM	Liters per Min	HP	GPM	Liters per Min	HP	GPM	Liters per Min	HP	GPM	Liters per Min	HP
	4.3	0,3	10	3,0	18	68	1/2	41	155	1	51	193	1 1/2	62	235	1 1/2
	8.7	0,6	20	6,1	17	64	1/2	40	151	1	50	189	1 1/2	60	227	1 1/2
	17.3	1,2	40	12,2	14	53	1/2	37	140	1 1/2	46	174	1 1/2	55	208	2
	26.0	1,8	60	18,3				32	121	1 1/2	42	159	2	50	189	2
	34.6	2,4	80	24,4							35	132	2	44	167	3

High Pressure	TOTAL HEAD				500 RPM			1160 RPM			1450 RPM			1750 RPM		
	PSI	Kgs per sq cm	Feet of Water	Meters of Water	GPM	Liters per Min	HP	GPM	Liters per Min	HP	GPM	Liters per Min	HP	GPM	Liters per Min	HP
	8.7	0,6	20	6,1	14	53	3/4	38	144	1 1/2	50	189	2	62	235	3
	21.6	1,5	50	15,2	12	45	3/4	34	129	1 1/2	44	167	3	54	204	3
	34.6	2,4	80	24,4	8	30	1	30	114	2	40	151	3	50	189	5
	47.8	3,4	110	33,5				28	106	2	36	136	3	47	178	5
	60.5	4,3	140	42,7				20	76	2	28	106	5	38	144	5

NOTE: Progressively longer life may be expected as operating pressures and speeds are reduced. Capacitor type motor recommended.

Table shows approximate Head-Flow for new pump in U.S. gallons per minute and liters per minute.

EXPLODED VIEW

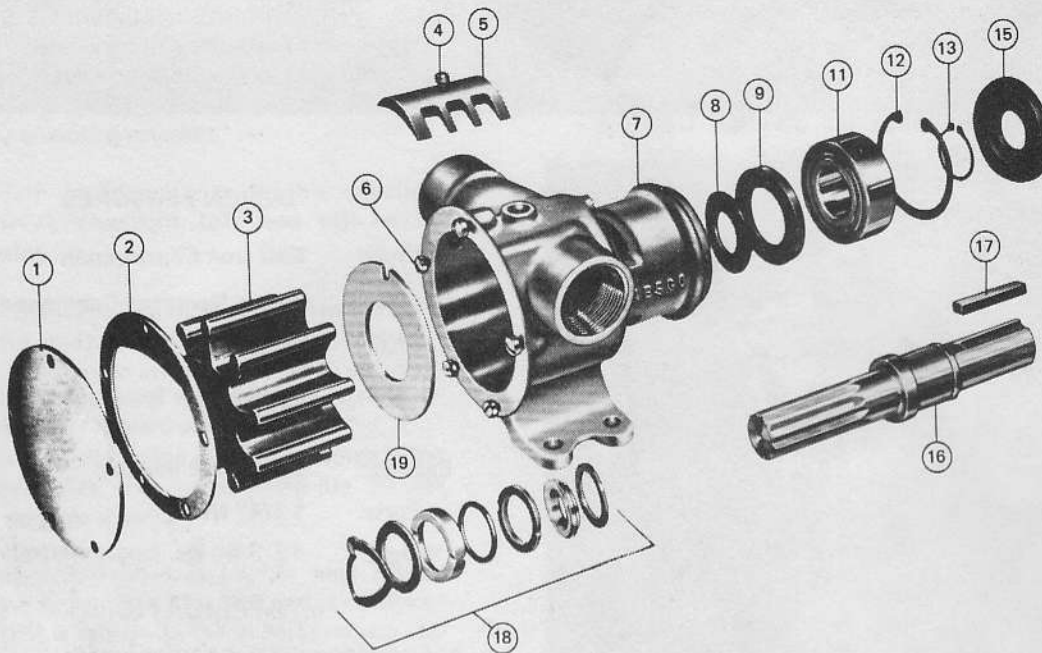

PARTS LIST

KEY	PART NUMBER	DESCRIPTION	QTY. REQ.
1	12045-0000	End Cover	1
2	* 816-0000	Gasket	1
3	* 790-0001	Impeller	1
4	91053-0070	Screw (Cam)	1
5	792-0000	Cam	1
6	91053-0070	End Cover Screws	5
7	12044-0000	Body	1
8	3181-0000	Slinger	1
9	817-0000	Bearing Seal (Inner)	1
11	92600-0040	Ball Bearing	1
12	91700-2460	Retaining Ring (Brg. to Body)	1
13	91700-2450	Retaining Ring (Brg. to Shaft)	1
15	818-0000	Bearing Seal (Outer)	1
16	1097-0000	Shaft	1
17	9214-0000	Key (Pump Drive)	1
18	* 1817-0040	Seal Assembly (Complete)	1
19	4193-0000	Wearplate	1
<b>Replacement Parts - High Pressure Model</b>			
3	1096-0001	Impeller (High Pressure)	1

\* Parts Found in Service Kit

Service Kit - 90116-0001

High Pressure Service Kit - 90116-0121

## SERVICE INSTRUCTIONS

### DISASSEMBLY

1. Remove end cover screws, end cover and gasket.
  2. Remove impeller (Picture No. 1).
  3. Remove seal with hooked wire. Remove seal seat and gasket (Picture No. 2).
  4. Loosen cam screw and remove cam. (Clean off permatex.)
  5. Remove wearplate.
  6. Insert screwdriver between O.D. of outer bearing seal and pump bore and pry out seal.
  7. Remove bearing to body retaining ring.
  8. Press on impeller drive end of shaft to remove shaft and bearing assembly. Heating outside of body at bearing will ease disassembly.
  9. Remove bearing to shaft retaining ring.
  10. Supporting bearing inner race, press shaft through bearing (Picture No. 3).
  11. Using extreme care not to mar body bore, insert screwdriver between O.D. of inner bearing seal and pump bore and pry out the seal.
- NOTE: Inspect all parts for wear or damage and replace if necessary.

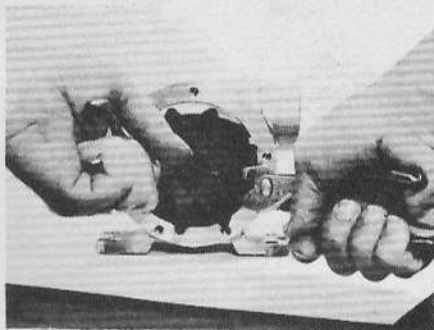

No. 1

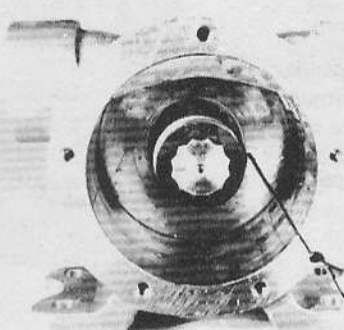

No. 2

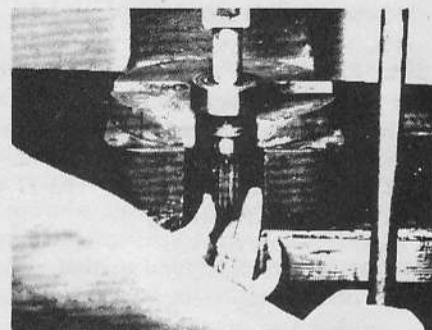

No. 3

### ASSEMBLY

1. Lubricate inner bearing seal with grease and press into body bearing seal bore with lip facing away from bearing bore.
  2. Press shaft into bearing, using care to support inner race of bearing.
  3. Install bearing to shaft retaining ring with flat side toward bearing.
  4. Position slinger in body drain area. Insert splined end of shaft through bearing bore and guide slinger over shaft until bearing contacts body.
  5. Pressing on bearing outer race, install bearing into bore. Heating outside of body at bearing area will ease assembly.
  6. Install bearing to body retaining ring in body groove with flat side toward bearing.
  7. Lubricate outer bearing seal with grease and press into bearing bore until it is flush with the body.
  8. Install wearplate in body bore, aligning slot in wearplate with dowel pin in body.
  9. Permatex screw threads and top surface of cam. Install in body with cam screw.
  10. Lubricate seal gasket of seal seat and gasket assembly with water and insert in seal bore of body with polished surface facing outward. Care must be taken not to mar or scratch seal seat face. Installing this assembly with a slight rotary motion will insure seating the gasket firmly in the cavity.
  11. Install balance of seal assembly with polished carbon seal face against seal seat. The seal assembly consists of the carbon seal ring and "O" ring which are contained within the metal ferrule. The metal ferrule has a neoprene cup washer covering its outside face against which the marcel spring washer is positioned.
- NOTE: It is advisable to position the marcel spring washer so that the drive points are aligned with the indentations in the ferrule face.
12. Lubricate impeller bore with a light coat of Marfak 2HD and start impeller into bore with a rotary motion until splines engage, then push into bore.
  13. Install gasket and end cover and secure with end cover screws.

## OPERATING INSTRUCTIONS

1. **INSTALLATION**—Pump may be mounted in any position. The rotation of the pump shaft determines the location of the pump's intake and discharge ports (refer to dimensional drawing). Before installing, turn the pump shaft in the direction of the operating rotation.
2. **DRIVE**—Belt or Direct with flexible coupling.  
**BELT DRIVE**—Overtight belt load will reduce pump bearing life.  
  
**DIRECT DRIVE**—Clearance should be left between drive shaft and pump shaft when installing coupling. Always mount and align pump and drive shaft before tightening the coupling set screw.
3. **SPEEDS**—100 RPM to the maximum shown in the performance table. For longer pump life, operate at lowest possible speeds.
4. **SELF-PRIMING**—Primes at low or high speeds. For vertical dry suction lift of 10 feet, a minimum of 800 RPM is required. Pump will produce suction lifts up to 22 feet when wetted. **BE SURE SUCTION LINES ARE AIR TIGHT OR PUMP WILL NOT SELF-PRIME.**
5. **RUNNING DRY**—Unit depends on liquid pumped for lubrication. **DO NOT RUN DRY** for more than 30 seconds. Lack of liquid will burn the impeller.
6. **CAUTION**—Do not pump petroleum derivatives, solvents, thinners, highly concentrated or organic acids. If corrosive fluids are handled, pump life will be prolonged if flushed with water after each use or after each work day.
7. **PRESSURES**—For continuous operation, pressure should not exceed 35 PSI for the standard Model 12040-0001 and 50 PSI using high pressure impeller.
8. **TEMPERATURES** 45° - 180° F.
9. **FREEZING TEMPERATURES**—Drain unit by loosening end cover.
10. **GASKET**—Use standard pump part. A thicker gasket will reduce priming ability. A thinner gasket will cause impeller to bind. Standard gasket is .015" thick.
11. **SPARE PARTS**—To avoid costly shut down, keep a Jabsco Service Kit 90116-0001 on hand.

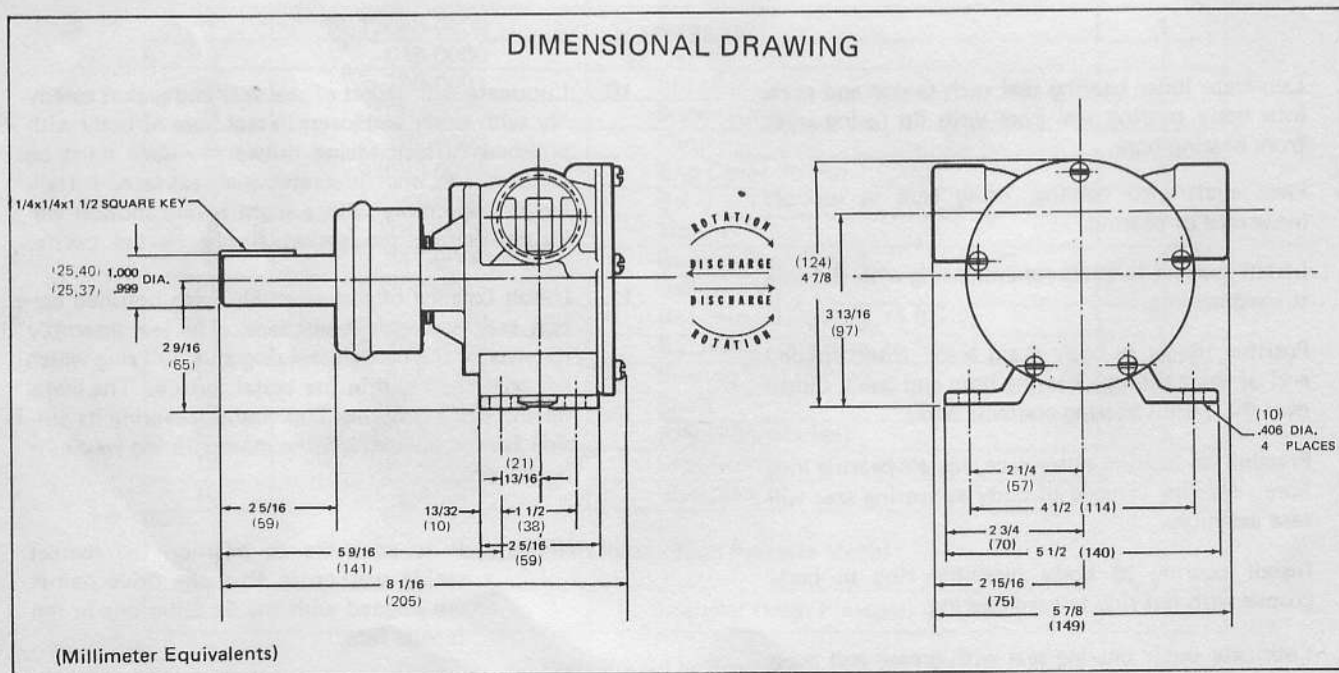

**JABSCO PRODUCTS**

A Unit of International Telephone and Telegraph Corporation, 1485 Dale Way, Costa Mesa, California 92626  
 Telephone: (714) 545-8251