

JABSCO®

BRONZE BALL BEARING SELF-PRIMING PUMPS

SERVICE INSTRUCTIONS

MODELS 11850-41 11850-51 11850-70
& 11850-71 - 3/4"

Used on Marine Engines Produced by:
 Crusader Marine Engine Div.
 Daytona Marine Engine Co.
 Osco Motors Corp.
 Palmer Engine Co.

DISASSEMBLY

1. Remove end cover screws, end cover and gasket.
2. Remove impeller by grasping hub with water pump pliers.
3. Loosen cam screw and remove cam (clean off Permatex).
4. Remove wearplate.
5. Insert a screwdriver in each opening of drain area between seal seat and brass washer. Using lever action against seal seat, force seal forward into impeller bore.
 If you have a stiff wire or welding rod approximately 1/8" diameter, bend 1/4" long right angle on two 6" lengths, and using in same manner as screwdriver force seal out of seal bore completely.
 If you do not have stiff wire available, pull seal out of bore by grasping outside of protruding seal with pliers.

6. Remove seal seat and brass washer with hooked wire.
7. Insert a screwdriver into "E" ring and hook it off the shaft.
8. Slide pulley from shaft.
9. Remove Woodruff Key.
10. Remove bearing to body retaining ring.
11. Pressing on impeller drive end of shaft, remove shaft and bearing assembly.
12. Supporting bearing inner race, press shaft through bearing.
13. Insert screwdriver thru impeller side of body and push out bearing seal thru bearing end.

CROSS SECTION

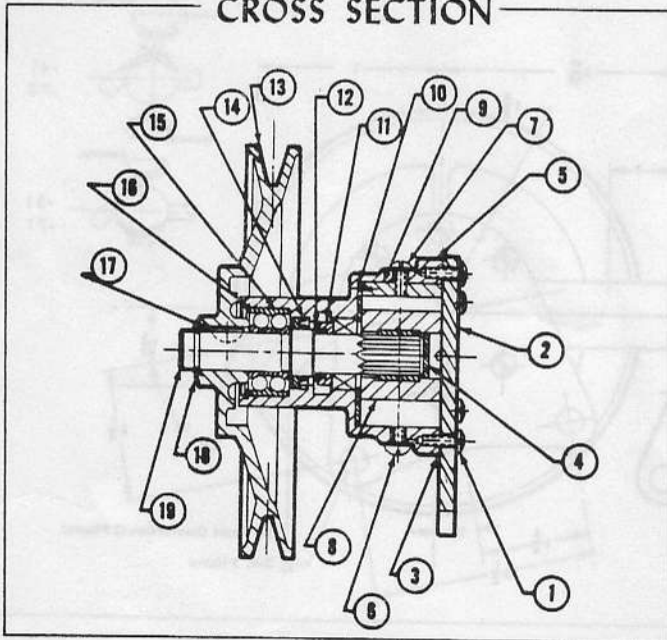

PARTS LIST

KEY	DESCRIPTION	PART NUMBER	QTY.
1	Screw (End Cover)*	SP 1026-01	6
2	End Cover:		
	Model 11850-41	11855-41	1
	Model 11850-51	11855-51	1
	Model 11850-70	12345	1
	Model 11850-71	12345-01	1
3	Gasket*	8641	1
4	Spline Seal	4345	1
5	Body	11854-41	1
6	Screw (Plug)	SP 1030-10	1
7	Screw	SP 1030-11	1
8	Impeller Assembly*	1210	1
9	Cam Assembly	8528	1
10	Wearplate	8493	1
11	Seal (Rotary)*	SP 6080-08	1
12	Washer	12019	1
13	Pulley	5668-01	1
14	Bearing Seal	SP 3000-09	1
15	Ball Bearing	SP 2600-07	1
16	Retaining Ring	SP 1700-248	1
17	Key	SP 1401-03	1
18	"E" Ring (Bowed)	SP 1700-249	1
19	Shaft	11977	1
20	Service Kit (Not Shown)	SK-124	

*Parts supplied in Service Kit

ASSEMBLY

1. Lubricate bearing seal with water pump grease or equivalent and push into body bearing seal bore with the lip facing away from bearing.
2. Press shaft into bearing. Use care to support inner race of bearing.
3. Press Woodruff Key into shaft key way.
4. Insert splined end of shaft into bearing bore and pressing on bearing outer race, press bearing into bore.
5. Install bearing to body retaining ring in body groove with flat side toward bearing.
6. While supporting splined end of shaft push pulley onto shaft.
7. Push "E" ring into groove in shaft.
8. Slide washer over splined end of shaft and down to shoulder.
9. Slide seal seat and gasket assembly with rubber inward over shaft and down against washer. Lubricate with water (do not use oil) to ease assembly.
10. With carbon facing in toward seat, press seal into bore. **CAUTION:** Press on outer-most edge of seal to prevent damage and press flush with bottom of body impeller bore.
11. Install wearplate in body.
12. Permatex screw threads, top side and back end of cam and install in body with cam screw. Be sure to align pin in cam with hole in wearplate.
13. Lubricate impeller bore with a light coat of water pump grease and start impeller into bore with a rotary motion, until splines engage, then push into bore.
14. Install gasket and end cover and secure with end cover screws.

OPERATING INSTRUCTIONS

- INSTALLATION**—The rotation of the pump shaft and the location of the cam determines the location of the pump's intake and discharge ports (refer to Dimensional Drawing). Before installing turn the pump shaft in the direction of the operating rotation.
- DRIVE**—Belt. Overtight belt or pulley misalignment will reduce pump bearing life.
- SPEEDS**—Designed for full range of engine speeds.
- SELF-PRIMING**—Primes at low or high speeds. **BE SURE SUCTION LINES ARE AIR TIGHT OR PUMP WILL NOT SELF-PRIME.**
- RUNNING DRY**—Unit depends on liquid pumped for lubrication. **DO NOT RUN DRY** for more than 30 seconds. Lack of liquid will burn the impeller.
- TEMPERATURES**—Standard impeller is designed to handle liquid temperatures between 45° and 180° F.
- FREEZING TEMPERATURES**—Drain unit by loosening end cover. The following anti-freeze compounds can be used without any adverse effect to the neoprene impeller: Atlas "Permaguard", DuPont "Zerex" and "Telar", Dow Chemical "Dowguard" and Olin Mathison "Pyro". Most methyl alcohol (methanol) based anti-freezes can be used. **DO NOT USE PETROLEUM BASED ANTI-FREEZE COMPOUNDS OR RUST INHIBITORS.**
- GASKET**—Use standard pump part. A thicker gasket will reduce priming ability. A thinner gasket will cause impeller to bind.
- SPARE PARTS**—A JABSCO Service Kit SK-124 should be kept on hand to service all but the most badly worn pumps.

HEAD CAPACITY TABLE

Pressure PSI	PUMP SPEEDS					
	500 GPM	1160 GPM	1750 GPM	2450 GPM	3000 GPM	3600 GPM
8.7	2.8	7.5	11.7	17.0	21.0	25.7
13.0	2.0	7.0	11.0	16.0	19.5	24.4
21.6	—	4.2	8.6	13.4	17.0	21.4

DIMENSIONAL DRAWING

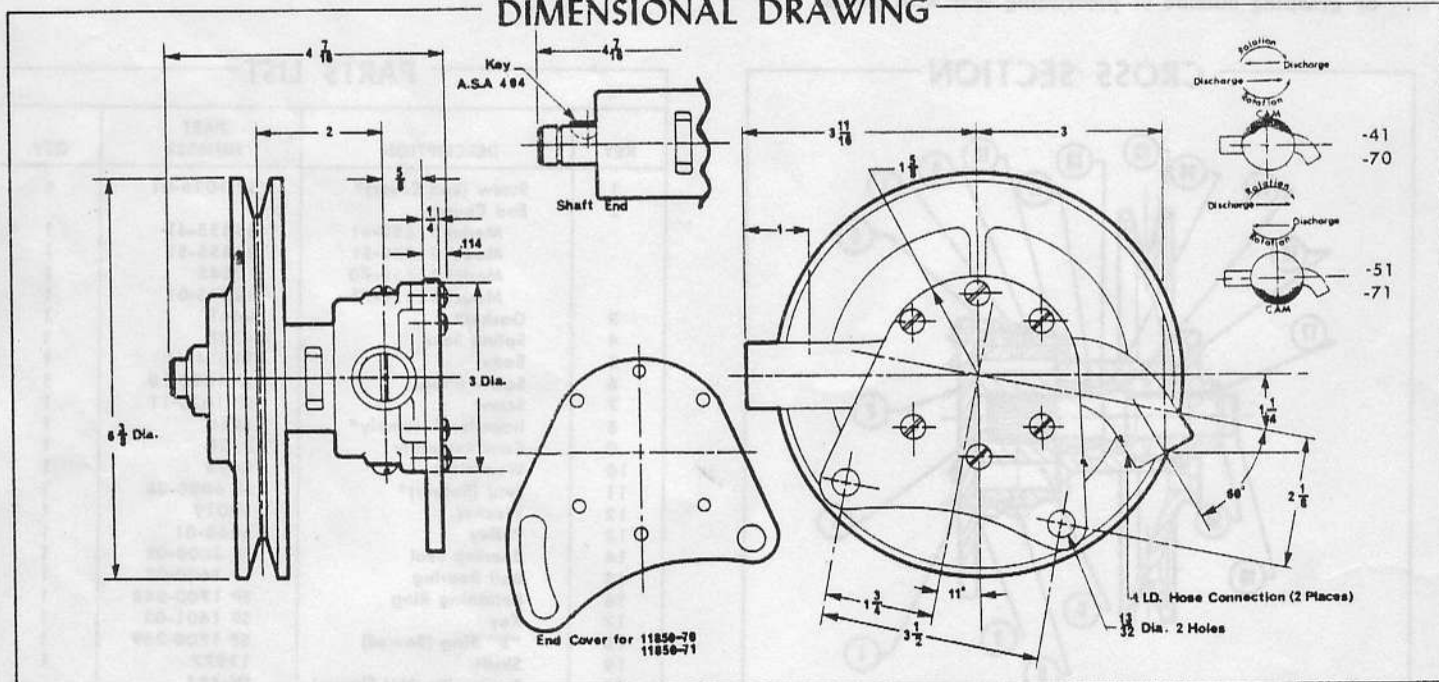

PARTS LIST (Variations)

MODEL	IMPELLER	SHAFT	SEAL	"O" RING	END COVER	EC SCREWS	SHAFT SCREW	WASHER
*11850	8444	8527	SP 2700-06	SP 2000-21	11855	SP 1026-01	SP 1095-32	SP 1613-06
*11850-01	8444	8527	SP 2700-06	SP 2000-21	11855-01	SP 1026-01	SP 1095-32	SP 1613-06
**11850-60	8444	8527	SP 2700-06	SP 2000-21	9049-02	SP 1003-01	SP 1095-32	8526
**11850-61	8444	8527	SP 2700-06	SP 2000-21	9049-03	SP 1003-01	SP 1095-32	8526

*Obsolete—Superseded by Models 11850-41 & 11850-51

**Special Model



JABSCO

PUMP COMPANY
1485 DALE WAY • COSTA MESA, CALIF.