

JABSCO® PUMPS

Self-Priming Pumps

MODELS: 11810-0121 12 Volts D.C.
 0321 32 Volts D.C.
 1101 110 Volts D.C.

PRODUCT DATA

125 IMP CHANGE

18815-0005

MODEL 11810-0121/11810-0321/11810-1101

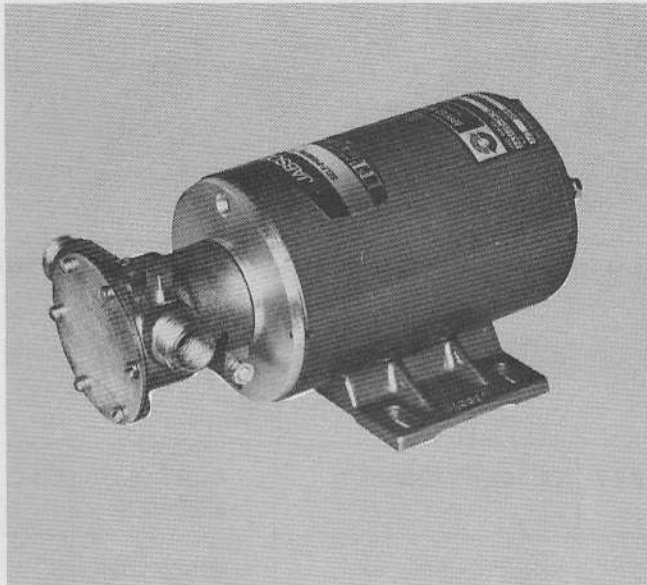

DESIGN FEATURES

- Body: **Bronze Construction**
- Impeller: **Jabasco Neoprene Compound**
- Shaft: **Motor Shaft is used—Steel with special Stainless Steel Sleeve**
- Wearplate: **Replaceable**
- Shaft Seal: **Mechanical Lip Type**
- Ports: **Both 3/4" Garden Hose External Thread and 1/2" Internal Pipe Thread**
- Motor: **1/3 H.P., 1800 RPM**
12 Volt D.C.: 28 AMP;
32 Volt D.C.: 9.5 AMP;
110 Volt D.C.: 2.6 AMP Open Flow
- Weight: **22 Lbs. (Approximately) (10 Kg.)**

APPLICATIONS

Ideal for bilge pumping, Bait Tank, Wash downs; and General Marine Service.

HEAD CAPACITY TABLE

TOTAL HEAD				1800 RPM	
Lbs. per sq. in.	Kg per sq. cm.	Ft. of Water	Meters of Water	GPM	Liters per min
4.3	,3	10	3	9.0	34
8.7	,6	20	6,1	8.0	30
13.0	,9	30	9,1	7.0	26
17.3	1,2	40	12,2	5.8	22

DIMENSIONAL DRAWING

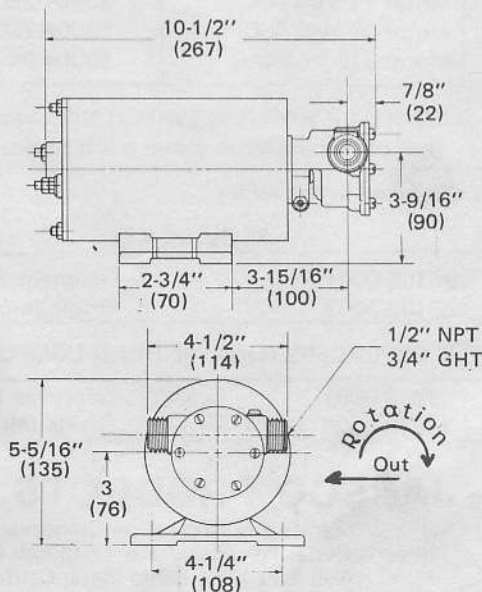

OPERATING INSTRUCTIONS

1. **INSTALLATION**—Pump may be mounted in any position without loss of efficiency; however, it is suggested that the pump head be down if vertical mounting is desired. The rotation of the motor shaft determines the location of the pump's intake and discharge ports. Refer to Dimensional Drawing. Right hand port, looking at pump end cover, is inlet port.
2. **DRIVE**—Direct.
3. **SELF-PRIMING**—Pump will produce a suction lift approaching 10 feet when dry, and a lift up to 22 feet when primed. **BE SURE SUCTION LINES ARE AIR TIGHT** or pump will not self-prime.
4. **RUNNING DRY**—Unit depends on liquid pumped for lubrication. **DO NOT RUN DRY** for more than 30 seconds. Lack of liquid will burn the impeller.
5. **CAUTION**—Do not pump solvents, thinners, highly concentrated or organic acids. If corrosive fluids must be handled, pump life will be prolonged if flushed with water after each use or after each work day. **MOTOR IS NOT EXPLOSION PROOF.**
6. **PRESSURES**—For continuous operation, pressure should not exceed 20 PSI (1,4 Kg per sq. cm.)
7. **TEMPERATURE**—Impeller supplied in pump is recommended for liquid temperatures of 45° - 180°F. (7.2° - 82.2°C). Optional Nitrile Impeller 50° - 180°F (10° - 82.2°C).
8. **SPARE PARTS**—To avoid costly shut downs, keep a Jabasco Service Kit on hand.

JABSCO PRODUCTS ITT

EXPLODED VIEW

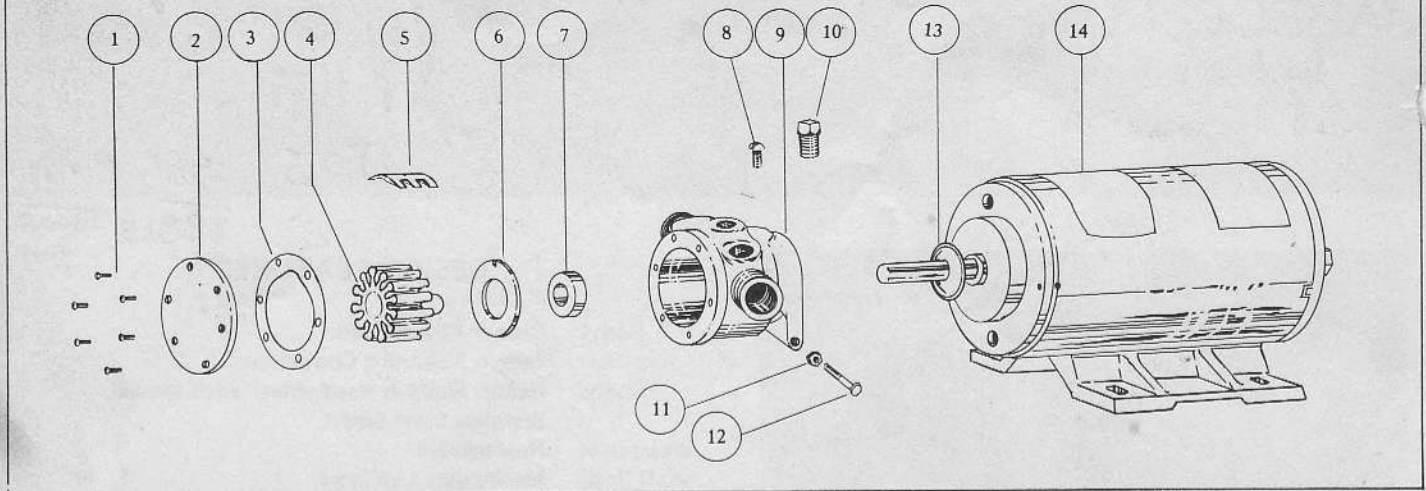

Insist on genuine Jabsco parts—made only by the ITT Jabsco Products—the original and world's leading manufacturer of self-priming flexible impeller pumps.

SERVICE INSTRUCTIONS

DISASSEMBLY

1. Remove end cover screws, gasket and end cover.
2. Grasp impeller hub with water pump pliers and withdraw from body.
3. Loosen cam screw and remove cam. Clean off Permatex. Remove wearplate with screwdriver or hooked wire.
4. Loosen nut at body clamp. Remove body from motor shaft.
5. Press out seal from motor mounting end of body towards impeller bore.
6. Remove slinger from shaft.

NOTE: Inspect all parts for wear or damage and replace if necessary. When returning to factory for repair—return the pump head only, unless motor repair is required.

ASSEMBLY

1. Install slinger and position 1/4" from motor boss.
2. Press seal into seal bore with lip facing toward the impeller bore. Apply grease to back of seal lip.
3. Install wearplate, aligning slot with dowel pin.
4. Permatex top of cam and cam screw threads. Install cam with cam screw.
5. Install body on motor. Tighten nut at clamp. Do not over-tighten or binding of shaft will result.
6. Lubricate impeller bore with Marfak 2HD grease or equivalent.
7. Lubricate shaft O.D. with grease, align drive ding in extended impeller insert with flat on shaft and install impeller.
8. Install gasket, end cover and end cover screws.

PARTS LIST

KEY	DESCRIPTION	PART NUMBER	QTY.
1	Screw (End Cover)	91002-0020	6
2	End Cover	11830-0000	1
3*	Gasket	11816-0000	1
4*	Neoprene Impeller	5929-0001	
	Nitrile Impeller	5929-0003	1
5	Cam	490-0000	1
6	Wearplate	2235-0000	1
7*	Seal (Shaft)	92700-0420	1
8	Screw (Cam)	91003-0010	1
9	Body	11814-0000	1
10	Plug (for vacuum switch hole)	92650-0070	1
11	Nut	91105-0030	1
12	Bolt	91095-0090	1
13	Slinger	6946-0000	1
14	Motor 12 Volt D.C.	93004-2602	1
	Motor 32 Volt D.C.	93004-2603	
	Motor 110 Volt D.C.	93004-2604	

4732-0000 — VACUUM SWITCH KIT — automatic shut off for use when pump is left unattended.

* Parts contained in service kit.

SERVICE KIT

90105-0001	Neoprene Impeller
90105-0003	Nitrile Impeller

REPLACEMENT PUMP HEAD COMPLETE

11818-0001	Neoprene Impeller
11818-0003	Nitrile Impeller

JABSCO PRODUCTS **ITT**

Marine and Recreation Components Division
International Telephone and Telegraph Corporation
1485 Dale Way, Costa Mesa, California 92626
Telephone: (714) 545-8251