

JABSCO® PUMPS

Self-Priming
Ball Bearing Pump

MODEL 1108-0001

PRODUCT DATA

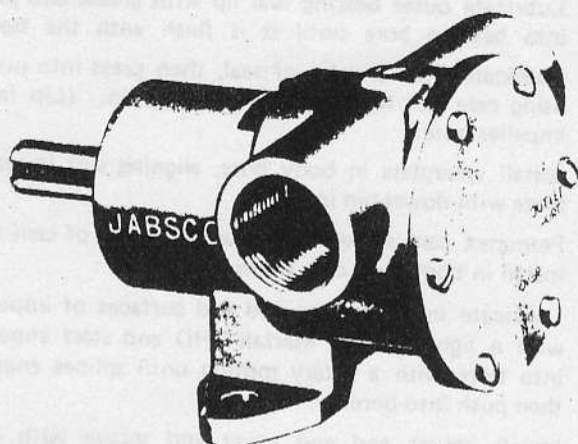

MODEL 1108-0001

DESIGN FEATURES

- Body: **Cast Iron Construction**
- Impeller: **Jabsco Neoprene Compound**
- Shaft: **Stainless Steel**
- Wearplate: **Replaceable**
- Shaft Seal: **Lip Type**
- Bearings: **Sealed Ball Bearings**
- Ports: **1" NPT**
- Weight: **5 lbs. (approximately) 2,3 Kgs**

TYPICAL APPLICATIONS

- Circulating and transferring liquids
- Returning spilled liquids to process
- Chemical manufacturers and pharmaceutical houses —to pump soap, liquors, ink, dyes, medicines, alcohol, various acids, tanning liquors, lotions, glycerine, etc.
- Circulating abrasive slurries (low speed — 500 RPM or less)
- Circulating and transferring alkaline solutions
- Inexpensive, expendable acid pump
- Circulating and processing wood pulp slurries
- Transferring and applying liquid fertilizers

HEAD CAPACITY TABLE

TOTAL HEAD		500 RPM		1160 RPM		1750 RPM	
P.S.I. (kg/sq cm)	Ft. of Water (meter)	GPM (L/min)	HP	GPM (L/min)	HP	GPM (L/min)	HP
4.3 (0,3)	10 (3,0)	6.8 (25,7)	1/4	16.5 (62,5)	1/3	26.0 (98,4)	3/4
8.7 (0,6)	20 (6,1)	6.3 (23,8)	1/4	15.9 (60,2)	1/2	24.5 (92,7)	3/4
17.3 (1,2)	40 (12,2)	4.7 (17,8)	1/4	13.5 (51,1)	1/2	21.0 (79,5)	3/4
26.0 (1,8)	60 (18,3)	—	—	9.5 (36,0)	3/4	16.5 (62,5)	1
34.6 (2,4)	80 (24,4)	—	—	—	—	11.5 (43,5)	1

Table shows approximate head-flow for new pump in U. S. gallons per minute with neoprene impeller Capacitor start or high starting torque motor recommended.

JABSCO PRODUCTS 

DISASSEMBLY

1. Remove and cover screws, end cover and gasket.
2. Grasp hub of impeller with water pump pliers and withdraw from body.
3. Remove cam screw and cam, clean permatex from cam and body bore.
4. Remove wearplate.
5. Insert screwdriver between O.D. of outer bearing seal and bearing bore, and pry seal out.
6. Remove bearing to body retaining ring.
7. Press on impeller drive end of shaft to remove shaft and bearing assembly.
8. Use extreme care not to mar body bore, insert screwdriver between O.D. of inner bearing seal and bearing seal bore and pry out seal.
9. Press seal out of body towards impeller bore.
10. Remove bearing to shaft retaining ring.
11. Support bearing inner race, press on drive end of shaft to remove shaft from bearing. Do not attempt to remove bronze bushing which is pinned to shaft.
12. Inspect all parts for wear or damage and replace where necessary.

ASSEMBLY

1. Lubricate inner bearing seal lip with grease and press into body bearing seal bore with lip facing away from bearing bore.

2. Assemble bearing to shaft, using care to support inner race of bearing, while pressing against the large shoulder of the bronze bushing.
3. Install bearing to shaft retaining ring with flat side toward bearing.
4. Position slinger in body drain area. Insert splined end of shaft through bearing bore and guide slinger over shaft until bearing contacts body.
5. Pressing on bearing outer race, install bearing into bore.
6. Install bearing to body retaining ring in body groove with flat side toward bearing.
7. Lubricate outer bearing seal lip with grease and press into bearing bore until it is flush with the body.
8. Lubricate O.D. and lip of seal, then press into place, using care not to damage or cut seal lip. (Lip faces impeller bore.)
9. Install wearplate in body bore, aligning slot in wearplate with dowel pin in body.
10. Permatex cam screw threads and top side of cam and install in body with cam screw.
11. Lubricate impeller bore and end surfaces of impeller with a light coat of Marfak 2HD and start impeller into bore with a rotary motion until splines engage, then push into bore.
12. Install gasket and end cover and secure with end cover screws.

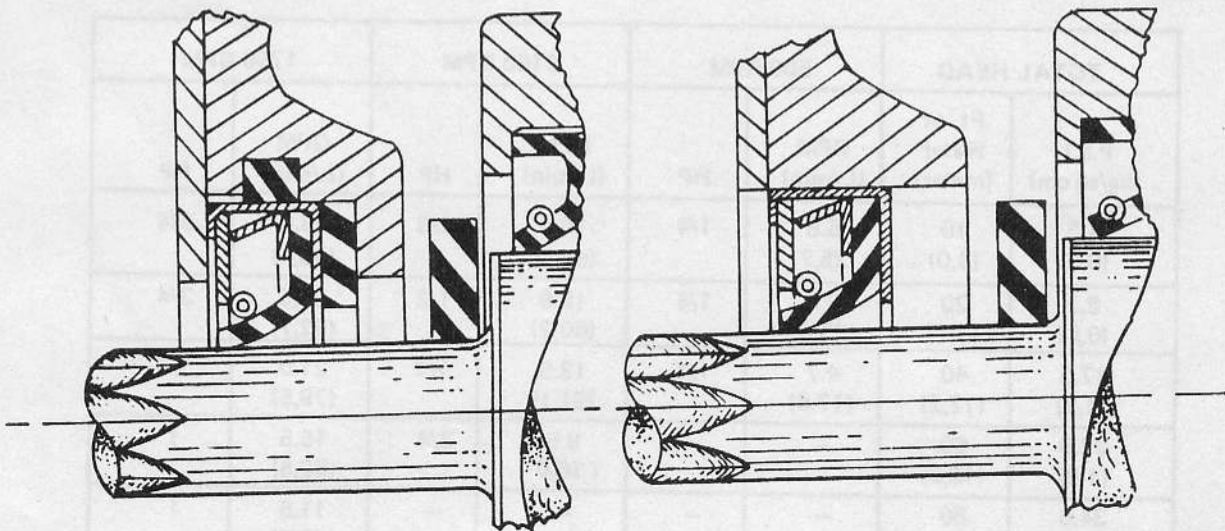

Lip seal with 92000-21 'O' Ring and 3166-0000 spacer, original seal design model 1108 prior to 1965.

Lip seal press fit — current assembly model 1108-0001.

EXPLODED VIEW

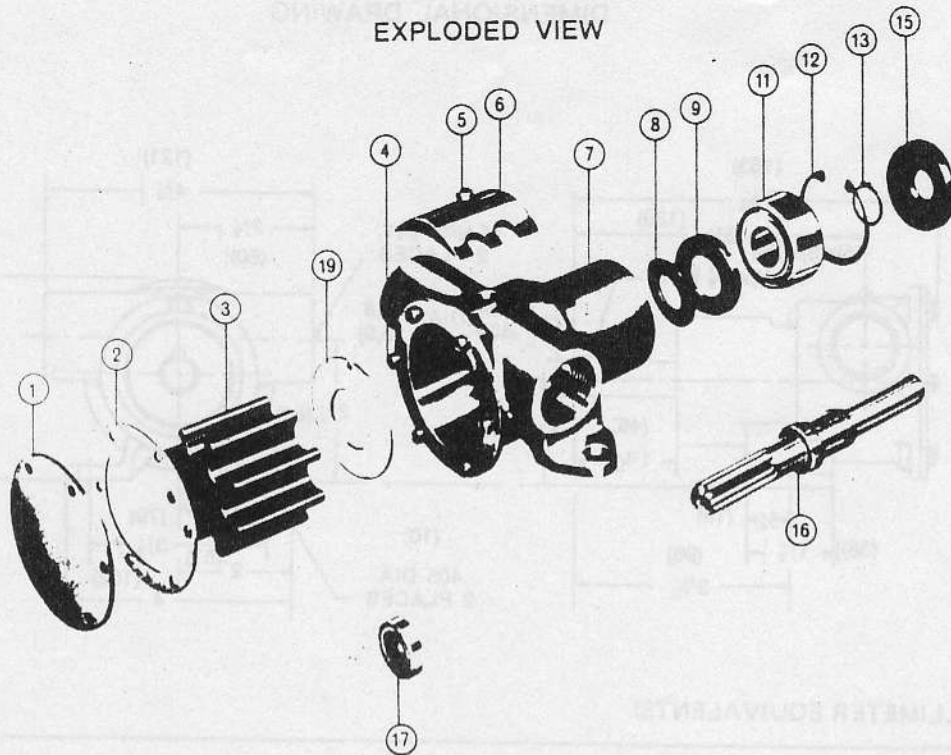

Insist on genuine Jabsco parts—made only by ITT Jabsco Products—the original and world's leading manufacturer of self-priming flexible neoprene impeller pumps.

PARTS LIST

Key	Part Number	Description	Qty. Req.
1	11834-0000	End Cover	1
2	890-0000	Gasket	1
3	1111-0001	Impeller	1
4	91053-0050	Screw (End Cover)	6
5	91053-0060	Screw (Cam)	1
6	1115-0000	Cam	1
7	1110-0000	Body	1
8	3180-0000	Slinger	1
9	913-0000	Bearing, Seal (Inner)	1
11	92600-0060	Bearing, Ball	1
12	91701-1850	Retaining Ring (Brg. to Body)	1
13	91700-2470	Retaining Ring (Brg. to Shaft)	1
15	914-0000	Bearing, Seal (Outer)	1
16	6718-0000	Shaft	1
17	92700-0290	Seal Lip	1
19	4176-0000	Wearplate	1
	9215-0000	Key-Pump Drive (Not Shown)	1

SERVICE KITS

Pump Model Number	Service Kit Number
1108-0001	90014-0001
Service Kit includes impeller, gasket, and seal assembly.	

DIMENSIONAL DRAWING

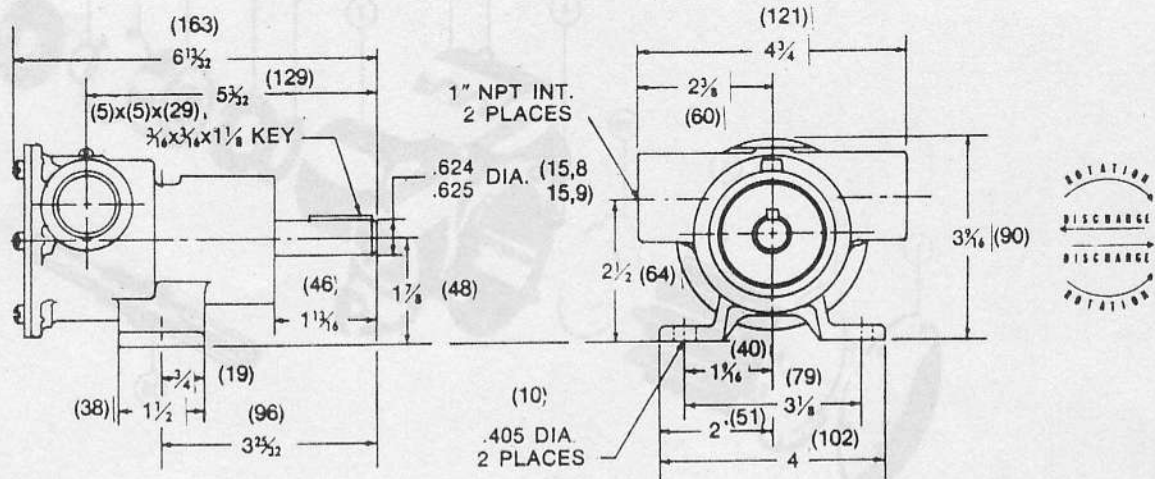

OPERATING INSTRUCTIONS

1. **INSTALLATION** — Pump may be mounted in any position. The rotation of the pump shaft determines the location of the pump's intake and discharge ports. Refer to dimensional drawing. Before starting, turn the pump shaft in the direction of the operating rotation.
2. **DRIVE** — Belt or Direct with flexible coupling.
BELT DRIVE—Overtight belt load will reduce pump bearing life.
DIRECT DRIVE—Clearance should be left between drive shaft and pump shaft when installing coupling. Always mount pump and align drive shaft before tightening the coupling set screw.
3. **SPEEDS**—100 RPM to the maximum shown in the performance table. For longer pump life, operate at lowest possible speeds.
4. **SELF-PRIMING** — Primes at low or high speeds. For vertical dry suction lift of 10 feet, a minimum of 800 RPM is required. Pump will produce suction lifts up to 22 feet when wetted. **BE SURE SUCTION LINES ARE AIR TIGHT OR PUMP WILL NOT SELF-PRIME.**
5. **RUNNING DRY** — Unit depends on liquid pumped for lubrication. **DO NOT RUN DRY FOR MORE THAN 30 SECONDS.** Lack of liquid will burn the impeller.
6. **CAUTION** — Do not pump petroleum derivatives, solvents, thinners, highly concentrated or organic acids. If corrosive fluids are handled, pump life will be prolonged, if flushed with water after each use or after each work day.
7. **PRESSURES** — For continuous operation, pressure should not exceed 30 psi for the standard Model 1108.
8. **TEMPERATURES**—NEOPRENE IMPELLER 45° TO 180°F. (7,2°- 82,2° C)
9. **FREEZING TEMPERATURES**—Drain unit by loosening end cover.
10. **GASKET**—Use standard pump part. A thicker gasket will reduce priming ability. A thinner gasket will cause impeller to bind. Standard gasket is .010 thick.
11. **SPARE PARTS** — A JABSCO 90014-0001 service kit should be kept on hand to service all but the most badly worn 1108-0001 pumps.

JABSCO PRODUCTS

A Unit of International Telephone and Telegraph Corporation, 1485 Dale Way, Costa Mesa, California 92626

Telephone: (714) 545-8251