

MODEL: 10170-0011

DESIGN FEATURES

- Body: Bronze
- Impeller: Jabasco Neoprene Compound
- Shaft: Bronze
- Shaft Seal: Carbon Ceramic Face-Type
- Ports: 1" Hose Connections (outer body)
1 1/4" Hose Connections (inner body)
- Weight: Approx. Shipping Weight, 6 1/2 lbs.

APPLICATION

Marine Engine Cooling
For Chrysler Engine Models:
M-431B, D and M-426B, D

DIMENSIONAL DRAWING

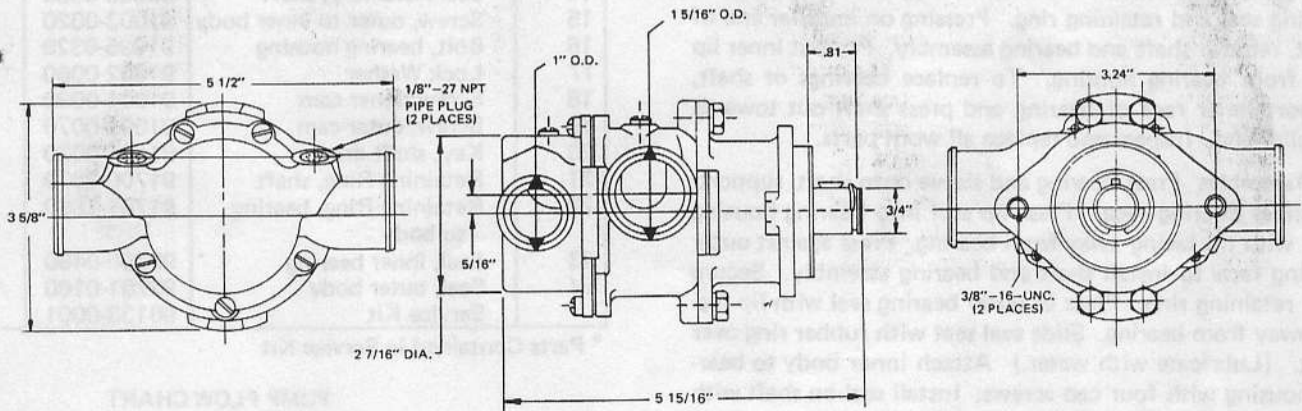

INSTALLATION INSTRUCTIONS

Mount pump on engine bracket. Make sure pump pulley is aligned with drive pulley and snap ring securely in place. Tighten belt by moving bracket. Allow about 1/2" movement in belt when tightened. Do not overtighten, connect inlet and outlet hoses, clamp securely on ports.

OPERATING INSTRUCTIONS

Pump will self prime at low or high speeds. Make sure scoop and inlet line are clear and all connections air tight. Do not run pump dry for more than 30 seconds. Lack of water flow may damage impeller.

EXPLODED VIEW

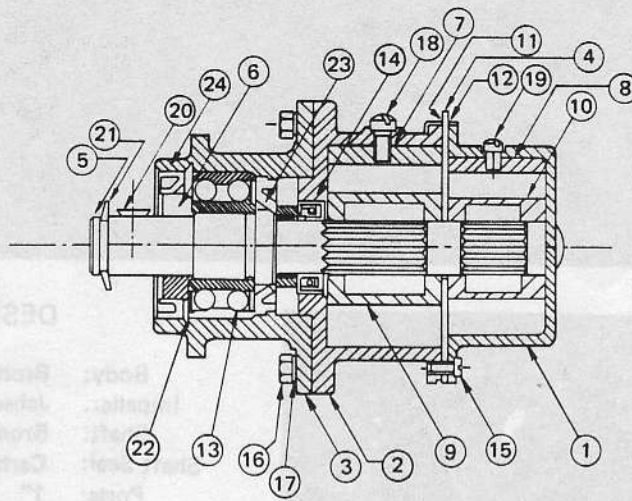

MODEL 10170-0011

SERVICE INSTRUCTIONS

Impeller Replacement: Remove outer body and gasket. Pull impeller out by grasping hub or blades with pliers. Remove wearplate, gasket and inside impeller. Replace impeller (8 blade), gasket and wearplate. Insert second impeller (12 blade) in outer body, place gasket on body. Push assembly onto shaft, lining up splines. A light coating of grease in impeller bores will aid priming on dry start up. (Use correct Jabsco gasket. A thicker or thinner gasket may cause impeller damage.) Standard gasket is .010" thick.

MAJOR REPAIR

Remove outer body, impeller and wearplate from pump. Remove inner impeller from inner body. Loosen four cap screws and remove inner body from bearing housing. Press out carbon face seal from inner body. Remove seal seat and seat gasket from shaft. Remove E clip, pulley, key, outer bearing seal and retaining ring. Pressing on impeller end of shaft, remove shaft and bearing assembly. Pry out inner lip seal from bearing housing. To replace bearings or shaft, support inner race of bearing and press shaft out towards impeller end. Inspect and replace all worn parts.

To Assemble: Press bearing and sleeve onto shaft, supporting inner bearing race. Press lip seal into bearing housing bore with lip facing away from bearing. Press against outer bearing race to install shaft and bearing assembly. Secure with retaining ring. Press in outer bearing seal with lip facing away from bearing. Slide seal seat with rubber ring over shaft. (Lubricate with water.) Attach inner body to bearing housing with four cap screws. Install seal on shaft with carbon face against seat and press flush with bottom of impeller bore. CAUTION: Press on outermost edge of seal to prevent damage, lubricate with water. (Do not use oil.) Do not mar nor scratch seal surface. Permatex screw threads, topside of cams and install in body with cam screw. Lubricate impeller bore with a light coat of water pump grease and start impeller (8 blade) into bore with a rotary motion until splines engage, then push into bore. Install gasket and divider plate. Push outer impeller (12 blade) into outer body with rotary motion. Place outer gasket in position on wearplate. Secure outer body. Tighten both (2) cam screws. Install key, pulley and E clip.

PARTS LIST

KEY	DESCRIPTION	PART NUMBER	QTY. REQ.
1	Body, outer	10185-0010	1
2	Body, inner	10176-0000	1
3	Bearing Housing	10178-0000	1
4	Wear Plate	10179-0000	1
5	Shaft	10180-0000	1
6	Sleeve	10181-0000	1
7	Inner Cam	10182-0000	1
8	Outer Cam	490-0000	1
9	* Inner Impeller	11979-0001	1
10	* Outer Impeller	1210-0001	1
11	* Inner Gasket	10184-0000	1
12	* Outer Gasket	10183-0000	1
13	Ball Bearing	92600-0060	1
14	* Seal Assembly, shaft	96080-0080	1
15	Screw, outer to inner body	91003-0020	5
16	Bolt, bearing housing	91095-0320	4
17	Lock Washer	91602-0060	4
18	Screw, inner cam	91004-0090	1
19	Screw, outer cam	91003-0070	1
20	Key, shaft drive	91401-0030	1
21	Retaining Ring, shaft	91700-2970	1
22	Retaining Ring, bearing to body	91701-1850	1
23	Seal, inner bearing	92700-0480	1
24	Seal, outer body	92701-0160	1
	Service Kit	90133-0001	

* Parts Contained in Service Kit

PUMP FLOW CHART

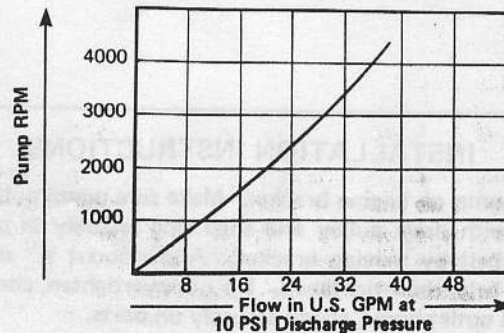

JABSCO PRODUCTS **ITT**

A Unit of International Telephone and Telegraph Corporation, 1485 Dale Way, Costa Mesa, California 92626

Telephone: (714) 545-8251