

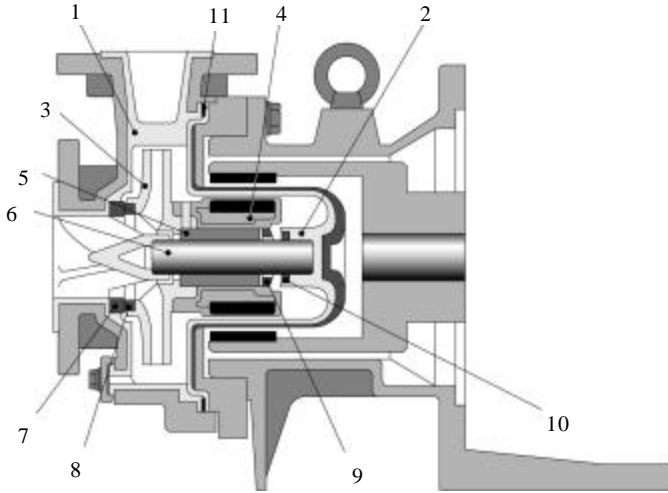

IWAKI WALCHEM Corporation

MDM-1516 3HP



- Non-contact Bearing System allows dry run operation (CF models only)
- Simple, rugged design
- Corrosion resistant ETFE & PFA internals
- Spline/pinned impeller design (pat. pending) provides positive locking of impeller/inner magnet while still allowing for individual replacement of each part

Part	Material		
	ECF	EKK	PKK
1 Front casing	CFRETFE (carbon fiber reinforced ETFE)		PFA
2 Containment shell			
3 Impeller			
4 Inner magnet assy			
5 Bearing	High density carbon	SiC	
6 Shaft	High purity alumina ceramic		
7 Front outboard thrust collar	PTFE		
8 Front inboard thrust collar	High purity alumina ceramic		
9 Rear inboard thrust collar	PTFE (filler charged)	PTFE	
10 Rear outboard thrust collar	PTFE		
11 Gasket	PTFE		

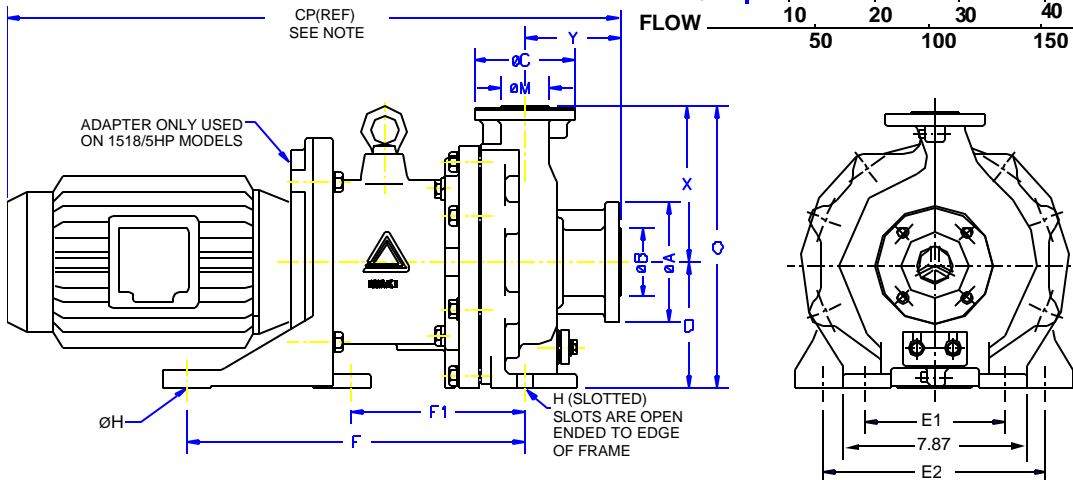
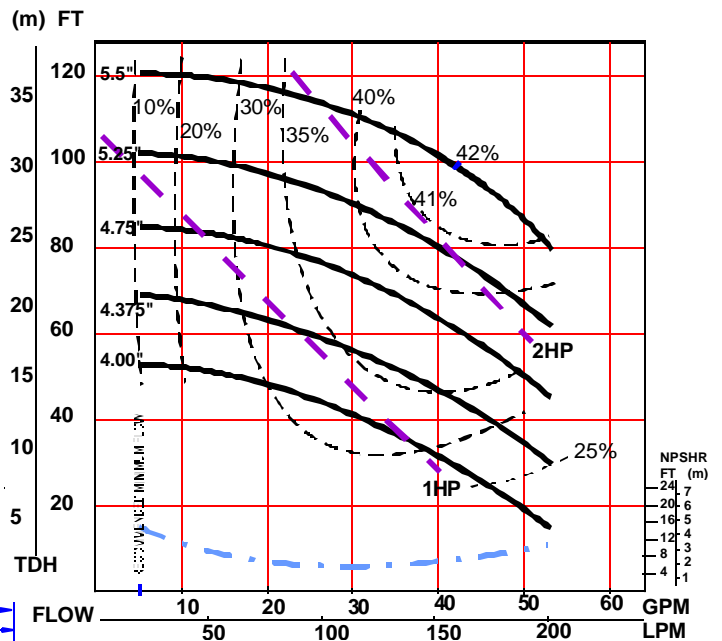

Dimensions (inches) and Specifications

Note: Will vary by motor manufacturer

CP	D	E1	E2	F	F1	H	O	X	Y
29	5.25	5.98	9.45	14.09	7.24	0.63	11.76	6.5	4.0
HP/Frame	Connection Sizes	Min Flow/Max Head	Standard Capacity	Max Cap.	Pump Weight				
3/182TC	1.5 x 1	5/120	42	53	110				



IWAKI WALCHEM Corporation

MDM-1518 5HP

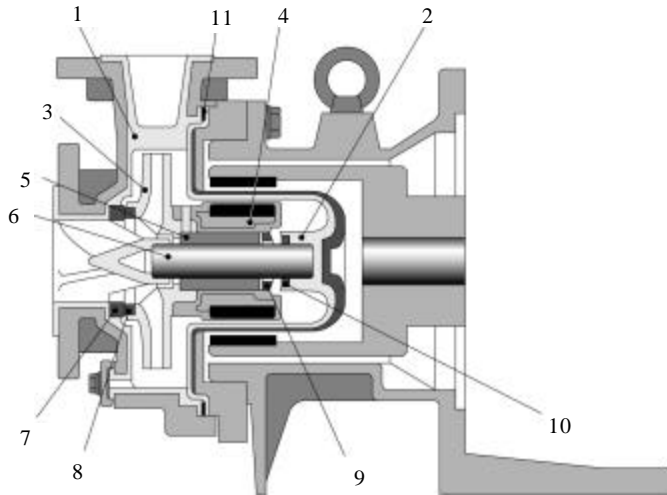

- Non-contact Bearing System allows dry run operation (CF models only)
- Simple, rugged design
- Corrosion resistant ETFE & PFA internals
- Spline/pinned impeller design (pat. pending) provides positive locking of impeller/magnet while still allowing for individual replacement of each part

Part	Material		
	ECF	EKK	PKK
1 Front casing	CFRETFE (carbon fiber reinforced ETFE)		PFA
2 Containment shell			
3 Impeller			
4 Inner magnet assy			
5 Bearing	High density carbon	SiC	
6 Shaft	High purity alumina ceramic		
7 Front outboard thrust collar	PTFE		
8 Front inboard thrust collar			
9 Rear inboard thrust collar	High purity alumina ceramic		
10 Rear outboard thrust collar	PTFE (filler charged)	PTFE	
11 Gasket	PTFE		

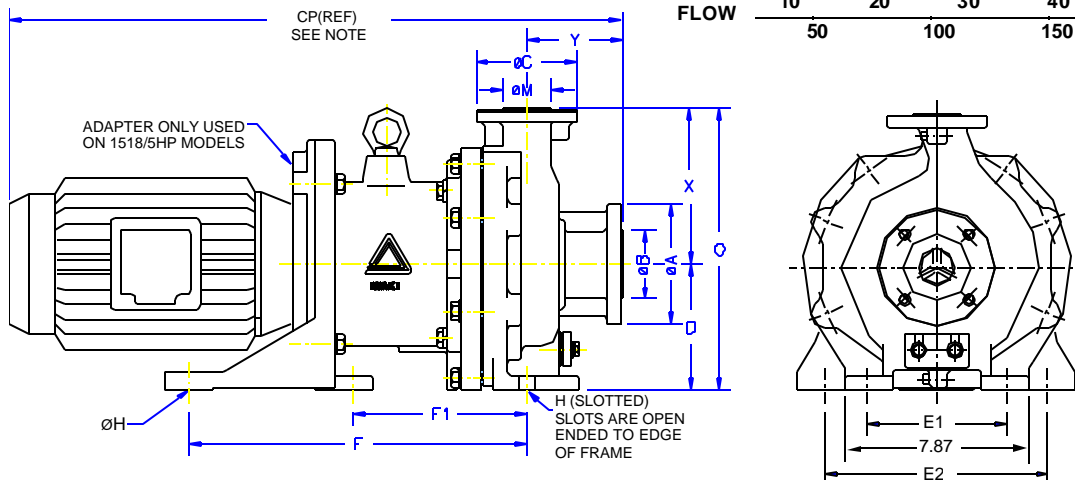
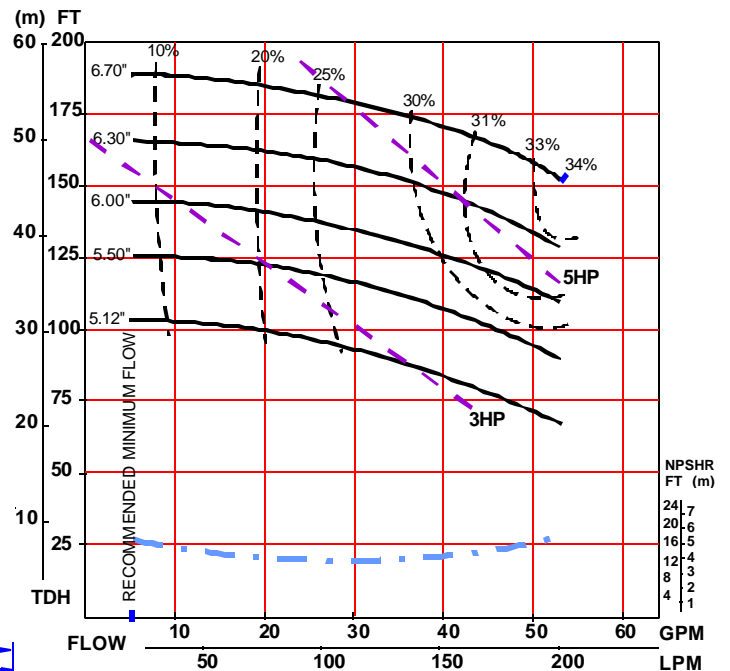

Dimensions (inches) and Specifications

Note: Will vary by motor manufacturer

CP	D	E1	E2	F	F1	H	O	X	Y
30	5.25	5.98	9.45	14.08	7.28	0.63	11.76	6.5	4.0
HP/Frame	Connection Sizes		Min Flow/Max Head		Standard Capacity		Max Cap.	Pump Weight	
5/184TC	1.5 x 1		5/192		53		53	132	



IWAKI WALCHEM Corporation

MDM-1518 7.5/10HP

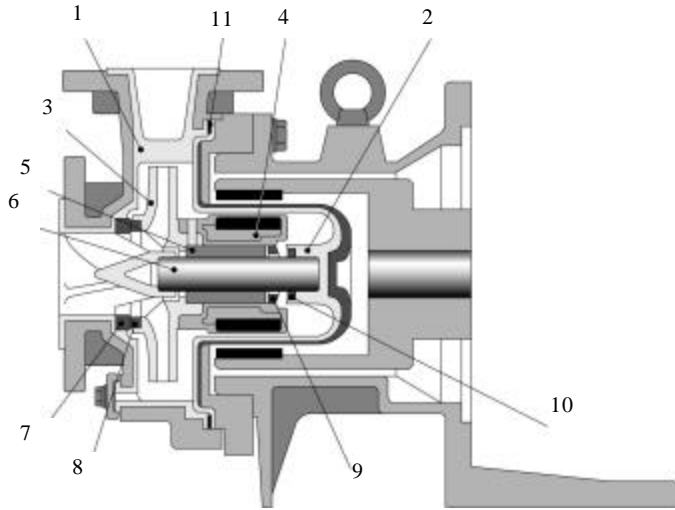

- Non-contact Bearing System allows dry run operation (CF models only)
- Simple, rugged design
- Corrosion resistant ETFE & PFA internals
- Spline/pinned impeller design (pat. pending) provides positive locking of impeller/magnet while still allowing for individual replacement of each part

Part	Material		
	ECF	EKK	PKK
1 Front casing	CFRETFE (carbon fiber reinforced ETFE)		PFA
2 Containment shell			
3 Impeller			
4 Inner magnet assy			
5 Bearing	High density carbon	SiC	
6 Shaft	High purity alumina ceramic		
7 Front outboard thrust collar	PTFE		
8 Front inboard thrust collar			
9 Rear inboard thrust collar	High purity alumina ceramic		
10 Rear outboard thrust collar	PTFE (filler charged)	PTFE	
11 Gasket	PTFE		

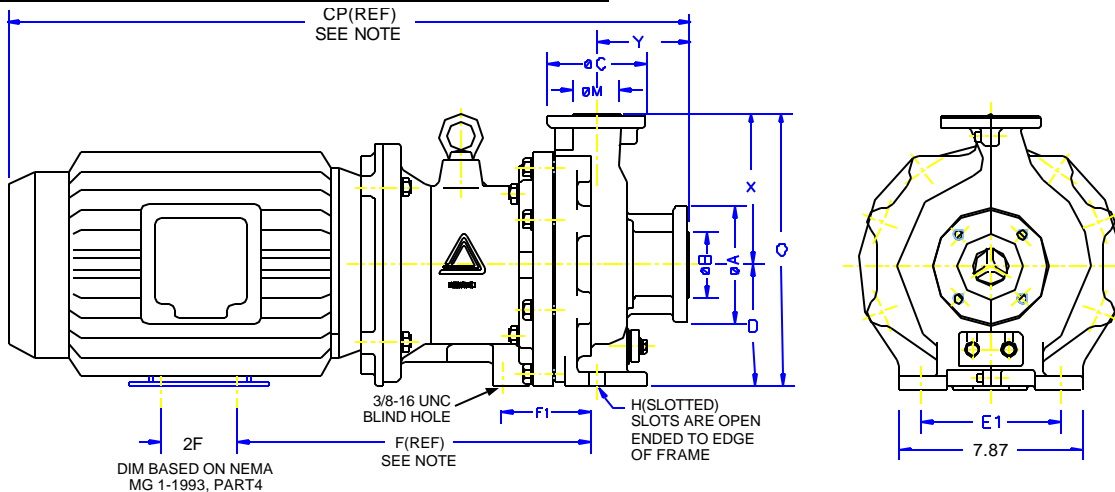
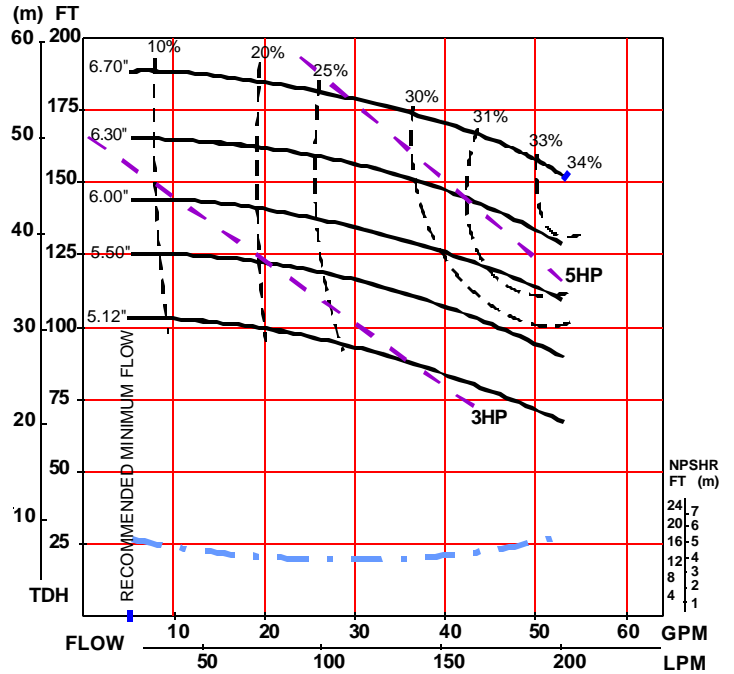

Dimensions (inches) and Specifications

Note: Will vary by motor manufacturer

CP	D	E1	F	F1	2F	H	O	X	Y
33.5	5.25	5.98	14.47	4.09	7.00	0.63	11.76	6.5	4.0
HP/Frame	Connection Sizes	Min Flow/Max Head	Standard Capacity	Max Cap.	Pump Weight				
7.5/213TC	1.5 x 1	5/192	53	53	132				
10/215TC									

IF20427.B 9/00

5 BOYNTON ROAD HOPPING BROOK PARK HOLLISTON, MA 01746-1446 USA
 TEL: 508-429-1440 FAX: 508-429-1386 WEBSITE: WWW.IWAKIWALCHEM.COM



IWAKI WALCHEM Corporation

MDM-2156 5HP

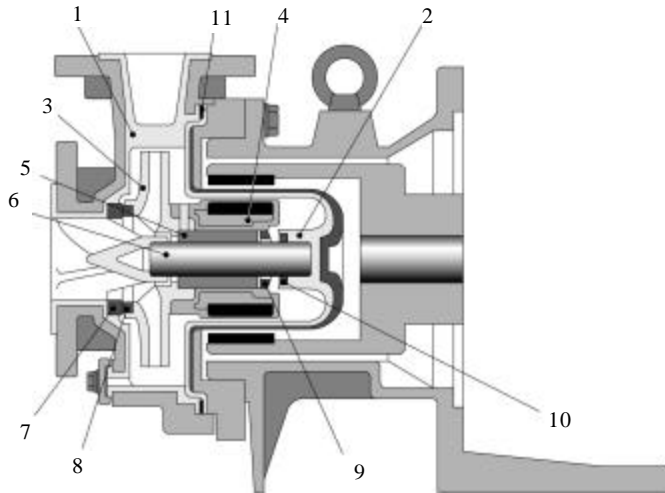

- Non-contact Bearing System allows dry run operation (CF models only)
- Simple, rugged design
- Corrosion resistant ETFE & PFA internals
- Spline/pinned impeller design (pat. pending) provides positive locking of impeller/magnet while still allowing for individual replacement of each part

Part	Material		
	ECF	EKK	PKK
1 Front casing	CFRETFE (carbon fiber reinforced ETFE)		PFA
2 Containment shell			
3 Impeller			
4 Inner magnet assy			
5 Bearing	High density carbon	SiC	
6 Shaft	High purity alumina ceramic		
7 Front outboard thrust collar	PTFE		
8 Front inboard thrust collar	High purity alumina ceramic		
9 Rear inboard thrust collar	PTFE (filler charged)		
10 Rear outboard thrust collar	PTFE		
11 Gasket	PTFE		

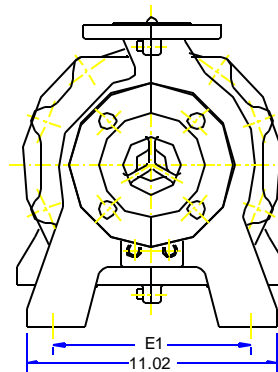
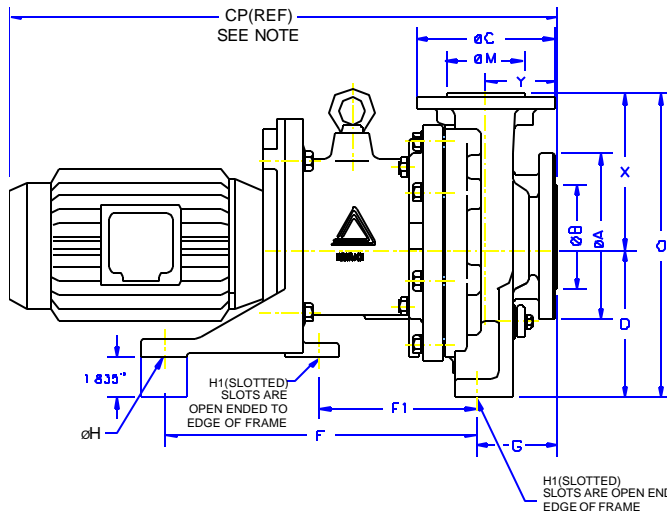
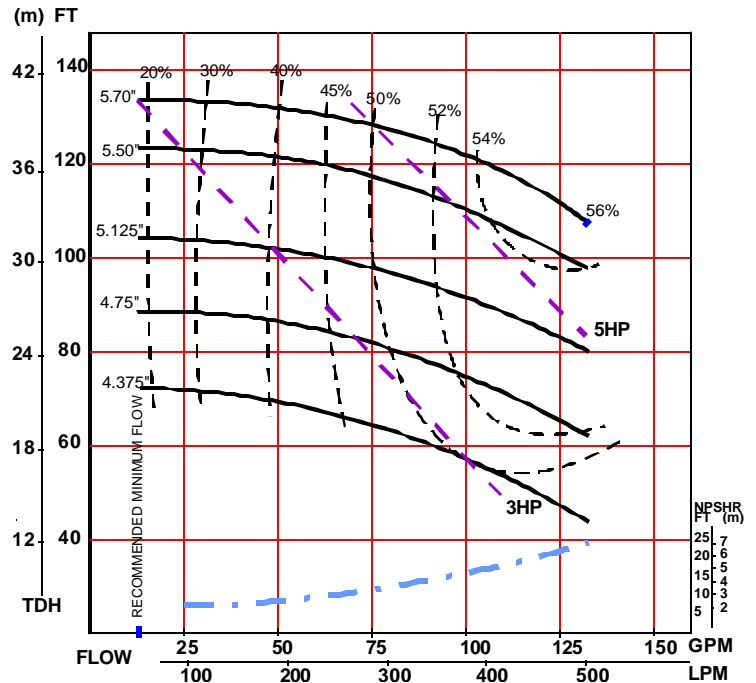

Dimensions (inches) and Specifications

Note: Will vary by motor manufacturer

CP	D	E1	F	F1	G	H	H1	O	X	Y
29	7.09	8.66	13.68	6.89	3.54	0.63	.055	13.39	6.3	3.15
HP/Frame	Connection Sizes		Min Flow/Max Head		Standard Capacity		Max Cap.		Pump Weight	
5/184TC	2 x 1.5		13/134		133		133		132	



IWAKI WALCHEM Corporation

MDM-2156 7.5/10HP

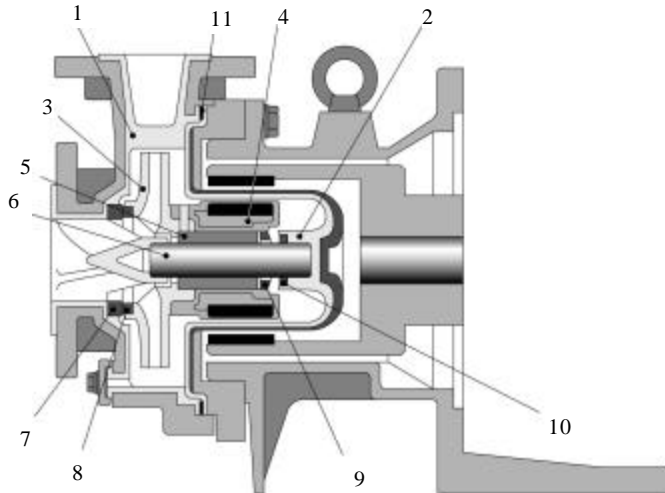

- Non-contact Bearing System allows dry run operation (CF models only)
- Simple, rugged design
- Corrosion resistant ETFE & PFA internals
- Spline/pinned impeller design (pat. pending) provides positive locking of impeller/magnet while still allowing for individual replacement of each part

Part	Material		
	ECF	EKK	PKK
1 Front casing	CFRETFE (carbon fiber reinforced ETFE)		PFA
2 Containment shell			
3 Impeller			
4 Inner magnet assy			
5 Bearing	High density carbon	SiC	
6 Shaft	High purity alumina ceramic		
7 Front outboard thrust collar			
8 Front inboard thrust collar	PTFE		
9 Rear inboard thrust collar	High purity alumina ceramic		
10 Rear outboard thrust collar	PTFE (filler charged)	PTFE	
11 Gasket	PTFE		

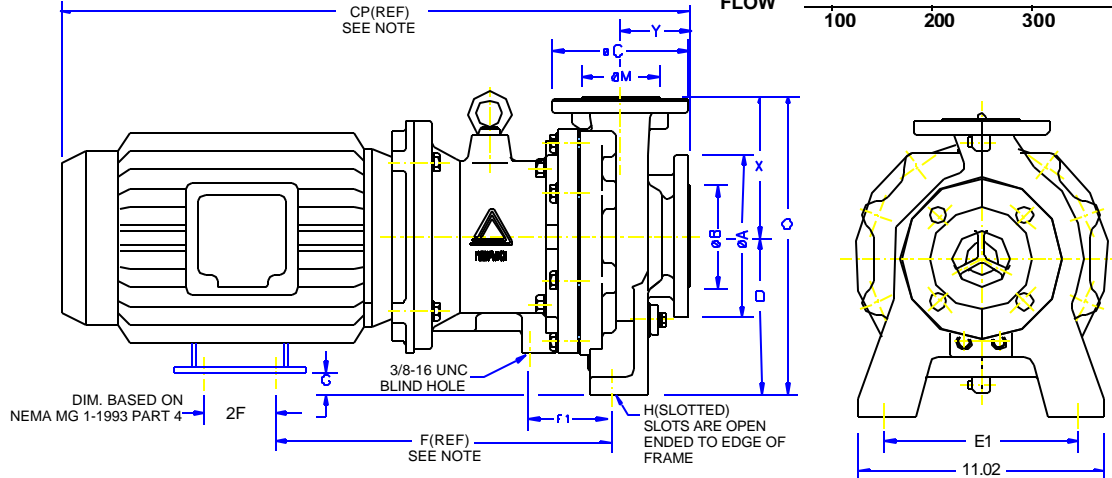
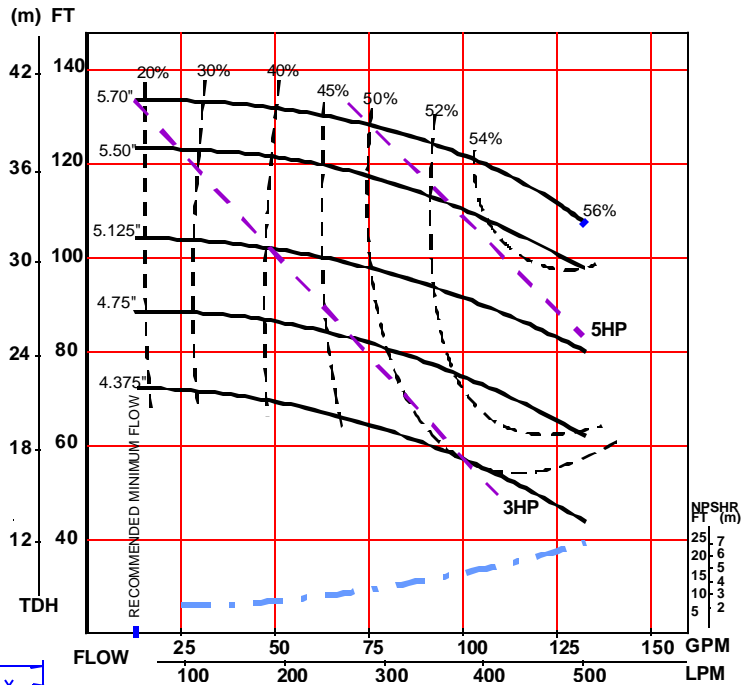

Dimensions (inches) and Specifications

Note: Will vary by motor manufacturer

CP	D	E1	E2	F	F1	2F	G	H	O	X	Y
31	7.09	8.66	11.02	14.45	3.70	7.00	1.83	0.55	13.39	6.3	3.15
HP/Frame	Connection Sizes		Min Flow/Max Head		Standard Capacity		Max Cap.		Pump Weight		
7.5/213TC	2 x 1.5		13/134		133		133		132		
10/215TC											



IWAKI WALCHEM Corporation

MDM-2526 5HP

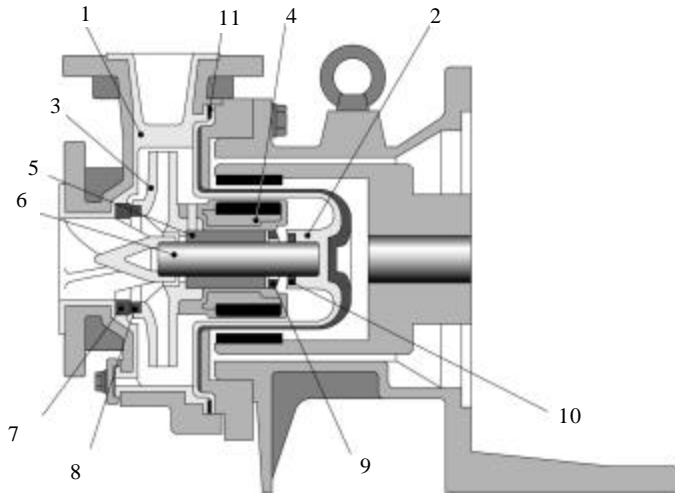

- Non-contact Bearing System allows dry run operation (CF models only)
- Simple, rugged design
- Corrosion resistant ETFE & PFA internals
- Spline/pinned impeller design (pat. pending) provides positive locking of impeller/magnet while still allowing for individual replacement of each part

Part	Material		
	ECF	EKK	PKK
1 Front casing	CFRETFE (carbon fiber reinforced ETFE)		PFA
2 Containment shell			
3 Impeller			
4 Inner magnet assy			
5 Bearing	High density carbon	SiC	
6 Shaft	High purity alumina ceramic		
7 Front outboard thrust collar	PTFE		
8 Front inboard thrust collar			
9 Rear inboard thrust collar	High purity alumina ceramic		
10 Rear outboard thrust collar	PTFE (filler charged)	PTFE	
11 Gasket	PTFE		

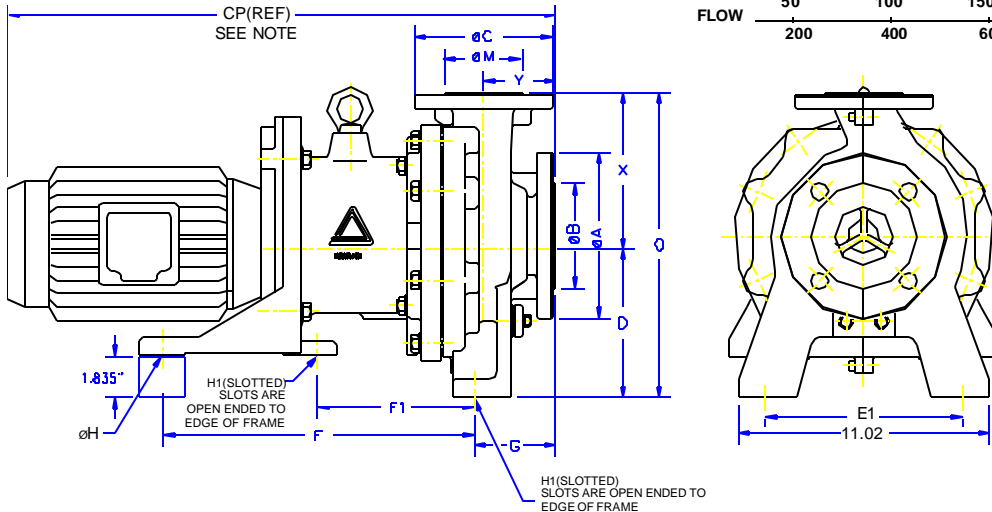
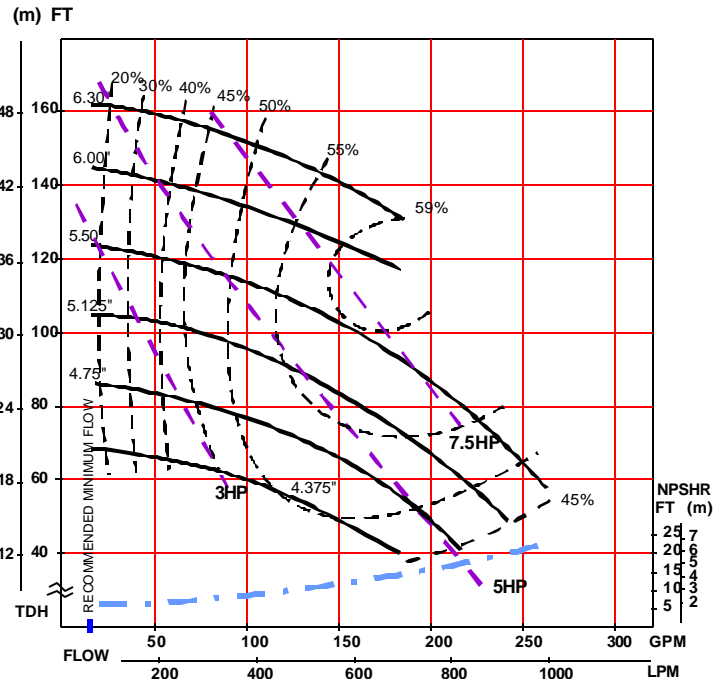

Dimensions (inches) and Specifications

Note: Will vary by motor manufacturer

CP	D	E1	F	F1	G	H	H1	O	X	Y
29	7.09	8.66	13.68	6.89	3.54	0.63	.055	13.39	6.3	3.15
HP/Frame	Connection Sizes		Min Flow/Max Head		Standard Capacity		Max Cap.	Pump Weight		
5/184TC	2.5 x2		13/162		180		260	132		

IF20430.B 9/00

5 BOYNTON ROAD HOPPING BROOK PARK HOLLISTON, MA 01746-1446 USA
 TEL: 508-429-1440 FAX: 508-429-1386 WEBSITE: WWW.IWAKIWALCHEM.COM



IWAKI WALCHEM Corporation

MDM-2526 7.5/10HP

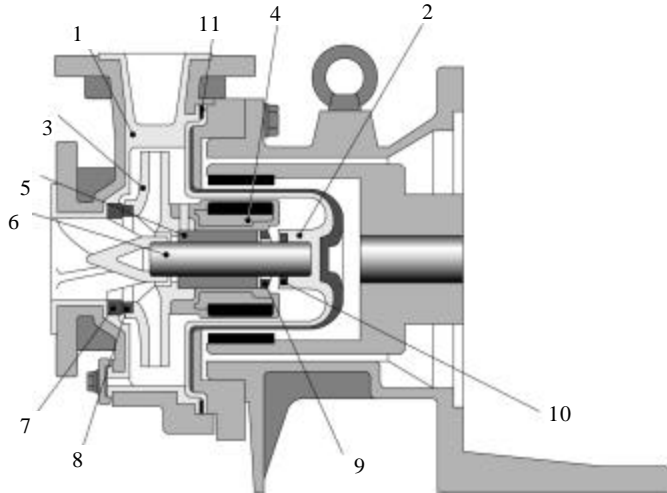

- **Non-contact Bearing System** allows dry run operation (CF models only)
- **Simple, rugged design**
- **Corrosion resistant** ETFE & PFA internals
- **Spline/pinned impeller design** (pat. pending) provides positive locking of impeller/magnet while still allowing for individual replacement of each part

Part	Material		
	ECF	EKK	PKK
1 Front casing	CFRETFE		PFA
2 Containment shell	(carbon fiber reinforced ETFE)		
3 Impeller			
4 Inner magnet assy			
5 Bearing	High density carbon	SiC	
6 Shaft	High purity alumina ceramic		
7 Front outboard thrust collar	PTFE		
8 Front inboard thrust collar	High purity alumina ceramic		
9 Rear inboard thrust collar	PTFE (filler charged)		
10 Rear outboard thrust collar	PTFE		
11 Gasket	PTFE		

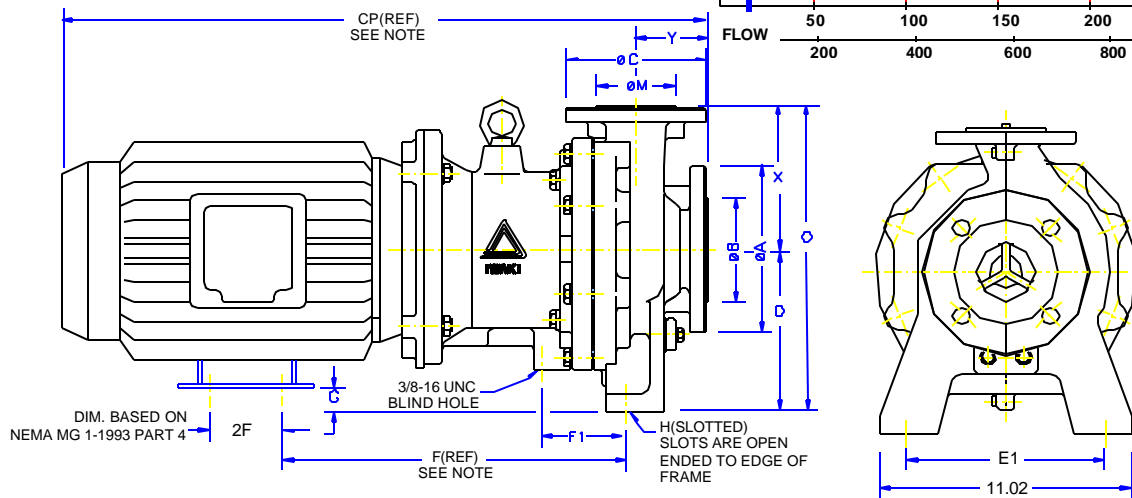
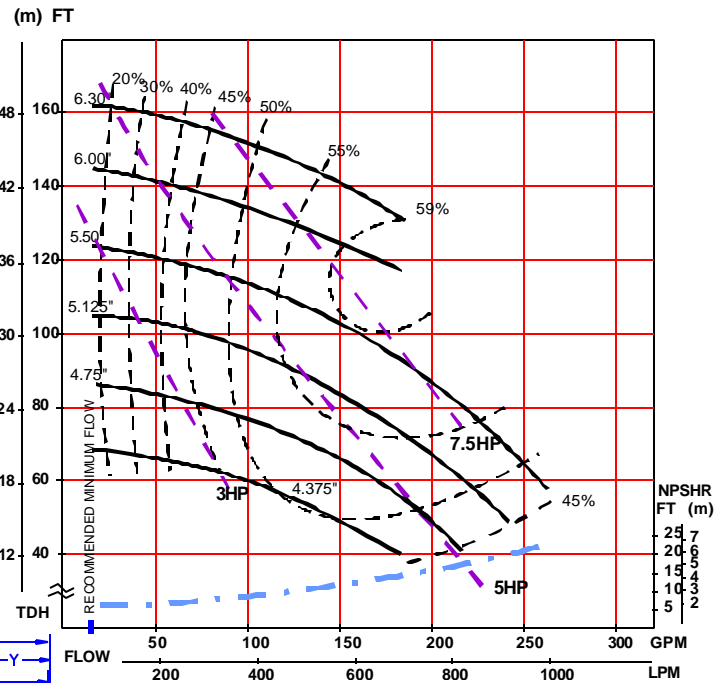

Dimensions (inches) and Specifications

Note: Will vary by motor manufacturer

CP	D	E1	E2	F	F1	2F	G	H	O	X	Y
31	7.09	8.66	11.02	14.45	3.70	7.00	1.83	0.055	13.39	6.3	3.15
HP/Frame	Connection Sizes		Min Flow/Max Head		Standard Capacity		Max Cap.		Pump Weight		
7.5/213TC	2.5 x 2		13/162		180		260		132		
10/215TC											



IWAKI WALCHEM Corporation

MDM-326 7.5-20HP

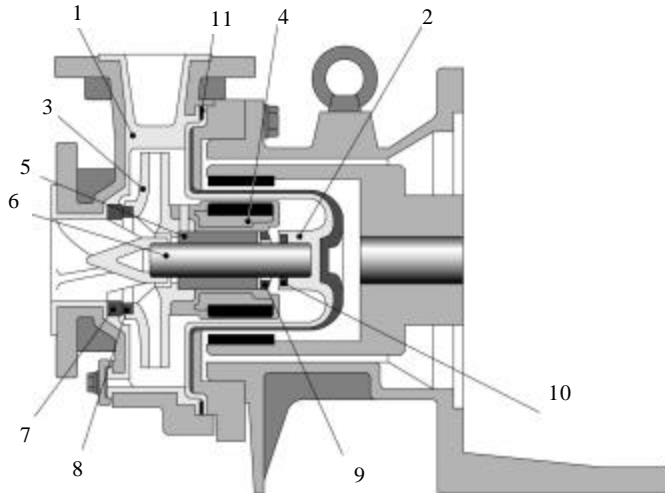

- Non-contact Bearing System allows dry run operation (CF models only)
- Simple, rugged design
- Corrosion resistant ETFE & PFA internals
- Spline/pinned impeller design (pat. pending) provides positive locking of impeller/magnet while still allowing for individual replacement of each part

Part	Material		
	ECF	EKK	PKK
1 Front casing	CFRETFE (carbon fiber reinforced ETFE)		PFA
2 Containment shell			
3 Impeller			
4 Inner Magnet assy			
5 Bearing	High density carbon	SiC	
6 Shaft	High purity alumina ceramic		
7 Front outboard thrust collar	PTFE		
8 Front inboard thrust collar	High purity alumina ceramic		
9 Rear inboard thrust collar	PTFE (filler charged)		
10 Rear outboard thrust collar	PTFE	PTFE	
11 Gasket	PTFE		

(m) FT

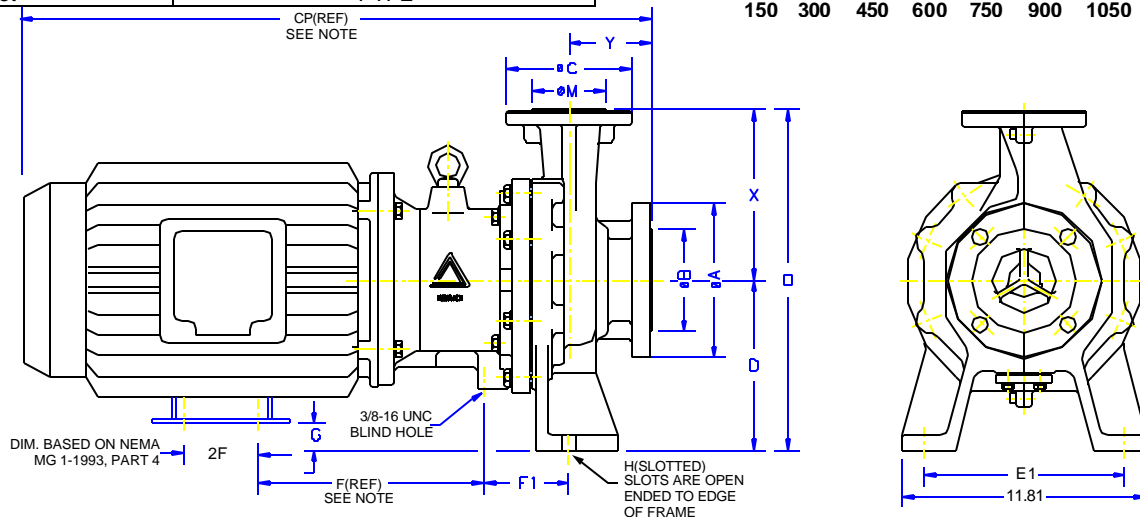
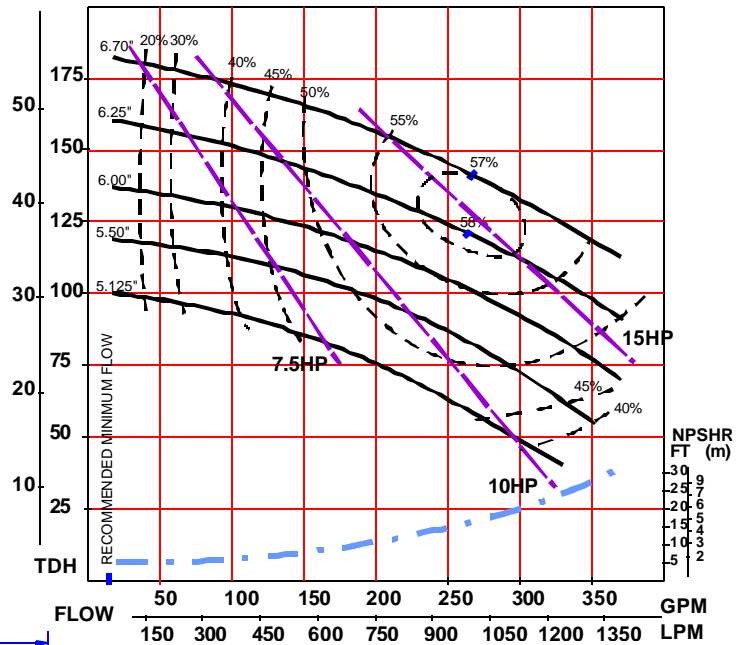

Dimensions (inches) and Specifications

Note: Will vary by motor manufacturer

HP/Frame	CP	D	E1	F	F1	2F	G	H	O	X	Y
7.5-213TC/10-215TC	31	8.25	9.76	14.46	4.09	7.00	2.99	0.63	16.5	8.25	4.0
15-254TC /20-256TC	36	8.25	9.76	14.97	4.09	8.25/10.0	1.99	0.63	16.5	8.25	4.0
Connection Sizes		Min Flow/Max Head		Standard Capacity		Max Capacity		Pump Weight			
3 x 2		13/182		262		367		144			

IF20432.C 10/00

5 BOYNTON ROAD
TEL: 508-429-1440

HOPPING BROOK PARK
FAX: 508-429-1386

HOLLISTON, MA 01746-1446 USA
WEBSITE: WWW.IWAKIWALCHEM.COM