

MDF-L250G

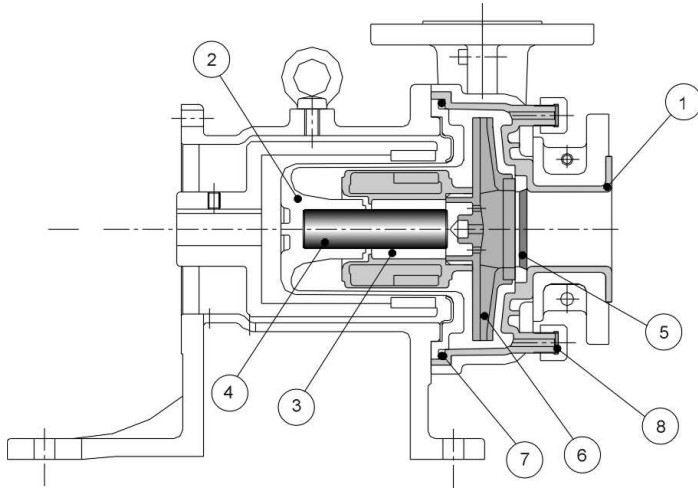

- Patented Pinpoint Bearing System allows dry run operation (CF models only)
- Compact design
- Corrosion resistant ETFE internals
- Precision injection molded, individually replaceable, liner components for simple on site maintenance

Part	Material	
	CF	AA
1 Casing Liner	20% carbon reinforced fluoroplastic	
2 Containment shell	ETFE	
3 Bushing	High density carbon	99.8% alumina ceramic
4 Shaft	99.8% alumina ceramic	
5 Thrust collar, inboard	99.8% alumina ceramic	
6 Impeller	20% carbon reinforced fluoroplastic	
	ETFE	
7 O-ring	FKM / EPDM / AFLAS	
8 Gasket	FKM / EPDM / AFLAS	

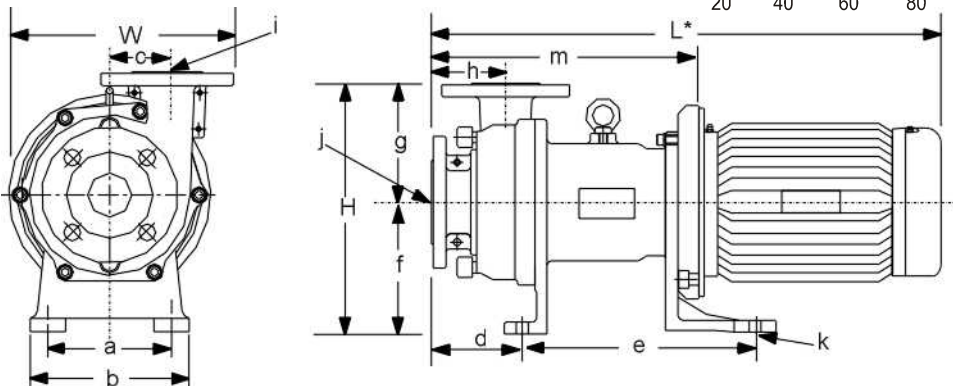
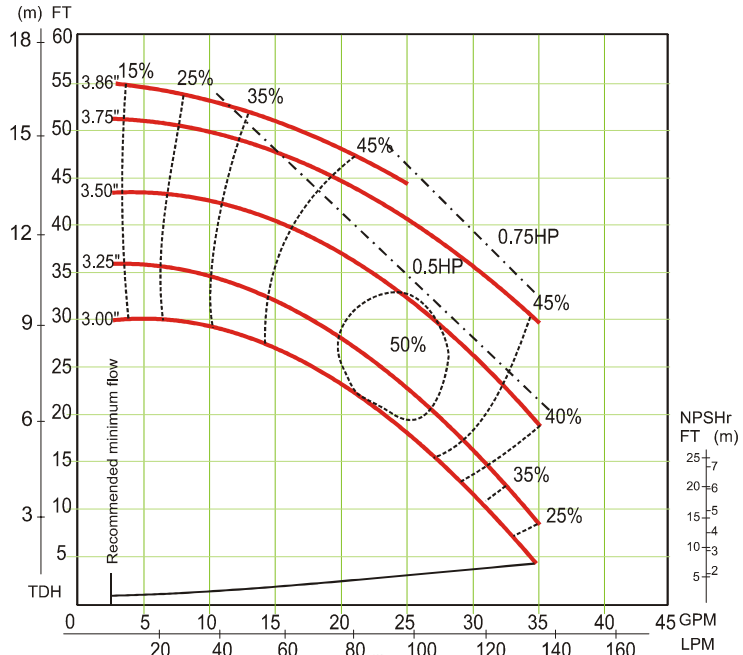

Dimensions (inches) and Specifications

* Will vary by motor manufacturer

a	b	c	d	e	f	g	h	i	j	m	k	W	H	L
4.3"	5.9"	2.0"	3.7"	5.6"	4.5"	4.8"	3.5"	1.0"	1.0"	9.1"	0.47"	8.1"	9.3"	17.3"
Connection Sizes		Min Flow/Max Head		Standard Capacity		Max Capacity		Motor / Frame		Pump Weight				
1 x 1		2.5 GPM/55 ft.		24 GPM/ 25 ft.		35 GPM		¾ HP / 56C		31 lbs.				