

# 1 Unpacking and Inspection

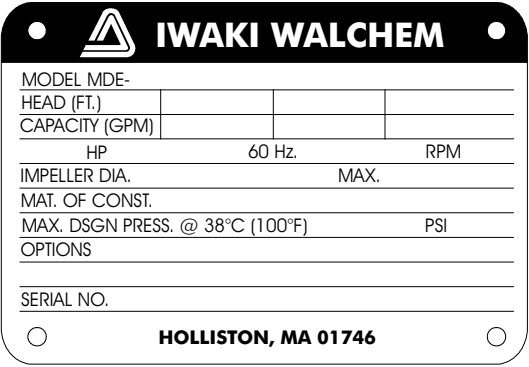

Open the package and check that the product conforms to your order. Also, check each of the following points. If there is a problem or discrepancy, contact your distributor at once.

1. Check that the model, head, capacity, material, motor output and voltage indicated on the nameplate conform to the specifications of your order.
2. Check that all the accessories you ordered are included.
3. Check that the pump body and parts have not been accidentally damaged nor any bolts and nuts loosened in transit.

## 2 Identification

---

### ■ Model Code

1	2	3	4	5	6	7
<b>MDE</b>	<b>AA</b>	<b>6</b>	<b>P</b>	<b>K</b>	<b>C</b>	<b>07</b>

1. Series Name

2. Pump bore symbol (suction × discharge)

AA: 1 ½ × 1

AB: 3 × 1 ½

3. Impeller nominal size

6: 6 inch

8: 8 inch

4. Materials of wetted parts

(portions made of resin)

P: PFA

E: ETFE

5. Bushing material

K: SiC

6. Motor type

C: Frame mounted type motor

F: Flange type motor (close-coupled)

7. Magnet Coupling Rating (@ 3600 RPM)

05: 5 HP                      15: 15 HP

07: 7 ½ HP                    20: 20 HP

10: 10 HP                      25: 25 HP

Options

No code: Without option

1: With leak sensor

2: With bearing temperature monitor

3: With bearing creep sensor

4: With bearing flusher

9: With two or more options

### 3 Specifications

3600 RPM / 60 Hz				
	Model	Connections Inlet x Outlet	Head feet	Rated Capacity gal/min
MDE	AA6	1 ½" x 1"	125	75
	AA8		250	100
	AB6	3" x 1 ½"	125	150

Notes:

- Standard performance (head/capacity) represents the maximum discharge quantity measured with pure water at 68° F.
- Liquid temperature range:  
PFA type ... 32~248° F  
ETFE type ... 32~212° F
- Slurry: Hardness 80Hs or below, grain size maximum 2 mil (50 microns), density maximum 5% wt. Contact Iwaki Walchem or your distributor for details.

#### Materials of main components

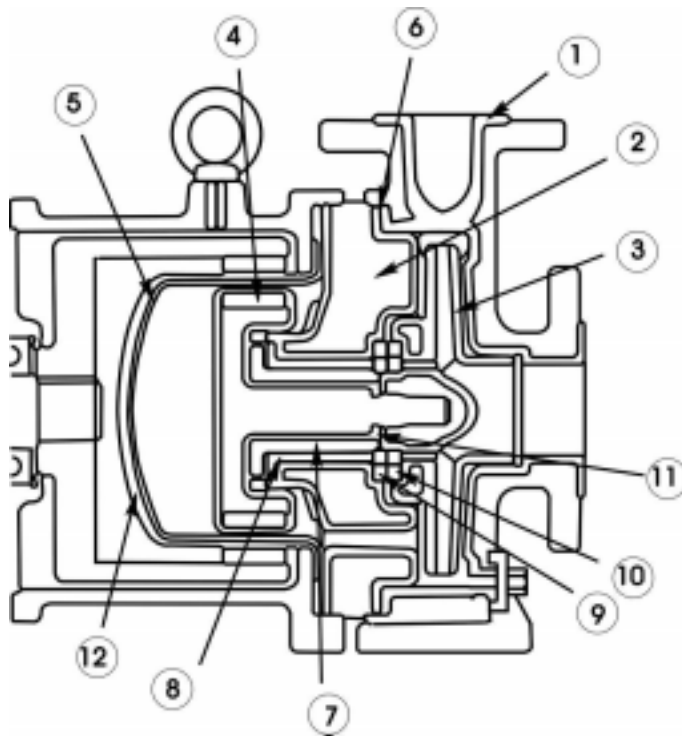

Part	Material	
	E	P
1. Casing Liner	ETFE	PFA
2. Casing Cover		
3. Impeller		
4. Magnet Assembly, inner		
5. Containment Shell		
6. Gasket	PTFE	
7. Bushing, Bearing inboard	SiC	
8. Bushing, Bearing outboard		
9. Thrust Collar inboard		
10. Thrust Collar outboard		
11. O-ring	Kalrez®	

## 4 Handling Instructions

### 1. Do not operate the pump dry.

The sliding parts used in the MDE series pumps are lubricated and cooled by the fluid being pumped. Never operate the pump dry or with the valves on the suction side closed. Otherwise, the inside of the pump will be damaged. If the pump is unavoidably or accidentally operated dry, with no obvious damage, allow the pump to cool down for a minimum of one hour before attempting to restart. Do not allow fluid to enter the pump cavity until the pump has cooled down. Sudden or rapid cooling of the pump may cause severe damage to the ceramic bearing system. A dry run device is recommended for the prevention of dry pump operation.

### 2. Points to be observed upon starting and stopping pump operation.

Pay close attention to the following points to avoid water hammer upon starting and stopping pump operation. Extra attention is required when the discharge piping is very long.

#### *Starting*

Prior to starting the pump, make sure that the power is turned off. Then carry out priming to fill the pump cavity with liquid. After priming is completed, rotate the coupling (or motor fan) by hand (five rotations or so) to expel air remaining in the impeller and bearing system of the pump.

#### Caution

Manually rotate pump drive shaft before start up to ensure ventilation of entrapped air. Failure to do so may result in damage to the pump bearing system.

Next, close the valves on the discharge side. Now you can turn power on and start up the pump. When the pump has reached full speed and line pressure is stable, the discharge valving can be opened to the desired settings.

#### Caution

If the pump is operated with air remaining in the pump cavity, biting, cracking or breakage of the bushing and/or thrust collar may occur, causing damage to the pump.

#### *Stopping*

When stopping the pump, first close the discharge valve gradually. When it is completely closed, turn off the power switch so that the pump stops.

Never stop the pump suddenly by quickly closing a valve (i.e., solenoid or hydraulic valves).

#### Caution

Quick valve closure may cause water hammer which can cause severe damage to the pump.

### 3. Maximum pressure rating.

The table on the right shows the maximum pressure rating for each model. Take care that

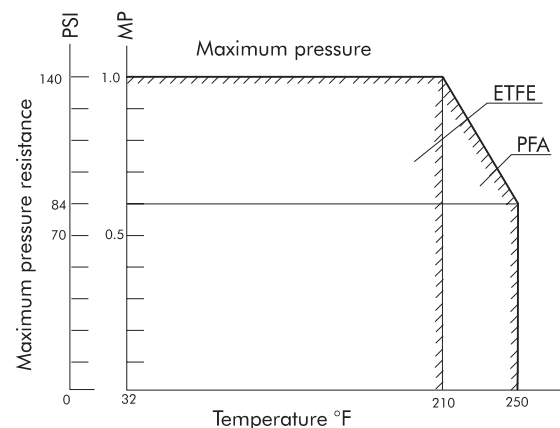

the discharge pressure does not exceed the maximum pressure rating.

Contact Iwaki Walchem or your distributor for the pressure rating of your pump if you are using an external flush, casing drain or monitoring options.

4. Handling of slurry liquid.

In general, slurries should not be handled. If the density is 5% wt or less and the grain size is 2mil (50 microns) or less, however, pumping is possible. Prior to pumping such slurry liquid, you should call Iwaki Walchem or your distributor to verify if the operation is feasible.

5. Influence of specific gravity on pump performance.

The performance of the pump does not change even for liquids of higher specific gravity. However, a magnet assembly and motor selected for the specific gravity should be used.

6. Influence of liquid viscosity on pump performance.

When pumping a high viscosity fluid, the discharge head and capacity of the pump may be lower than in the case of pure water. The required driving power may also vary and should be checked.

7. Intermittent operation.

Frequent start/stop switching considerably shortens the service life of the pump. Limit the frequency of switching to six times per hour.

8. Influence of temperature.

The pump itself may not suffer a change in performance due to temperature fluctuation. However, the liquid may change in terms of viscosity, vapor pressure, and corrosive resistance. Pay special attention to changes in liquid characteristics as a result of temperature fluctuation.

## 5 Installation, Piping and Wiring

---

### ■ Installation position

- 1 Install the pump as close to the suction tank as possible (flooded suction). If the suction port of the pump is positioned higher than the suction tank (suction lift), be sure to arrange a foot valve in the priming pipe and suction pipe. The lifting capability depends upon the liquid properties, temperature, and length of suction piping. For details, consult Iwaki Walchem or your distributor.
2. The pump can be installed for use indoors or outdoors. However, there should be sufficient space around the pump to enable efficient and easy maintenance.

### ■ Installation

1. The pump anchoring area must be greater than the area of the base. If the anchoring area is not large enough, the base may be damaged due to the concentration of loads placed on it.
2. Set the pump base on a concrete foundation and fasten the anchor bolts tightly to prevent the pump from vibrating during operation.

3. Insert a spacer between the concrete surface and the bottom of the base to level the pump horizontally. Next, put a level on the discharge flange surface to adjust the pump horizontally in the direction of the pump shaft. Also adjust the direction vertical to the pump shaft at the same time by placing a level on the suction flange surface. Pour cement mortar into the foundation bolt holes after leveling has been completed. When the cement mortar is hardened, fasten the anchor bolt nuts firmly. (See Fig. 1)

4. In case there is influence of motor vibration during operation (e.g., sympathetic vibration with piping), an expansion joint should be provided between the pump and the piping before the installation. Otherwise, pipes and gauges may be damaged.

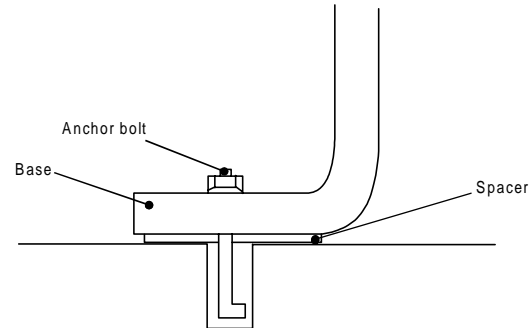

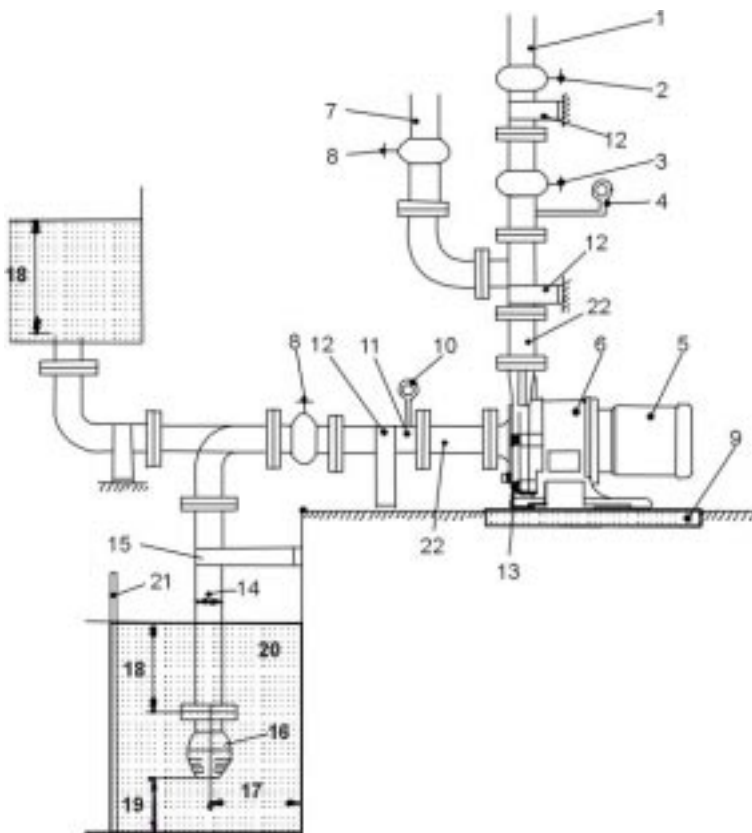

## ■ Piping



1. Discharge pipe (Use a support to keep the pump free from the load of the pipe.)
2. Discharge valve.
3. Check valve.
4. Pressure gauge.
5. Motor.
6. Pump.
7. Priming pipe.
8. Gate valve.
9. Drain ditch.
10. Compound gauge.
11. Suction pipe (Diameter = D) (shortest horizontal section with an ascending gradient toward the pump).
12. Pipe support.
13. Pump drain.
14. Suction pipe (D: diameter of pipe).
15. Suction pipe stabilizer brace (Used if the suction pipe is particularly long.)
16. Foot valve.
17. 1.5D or more.
18. 2D, or 24 inches or more.
19. 1~1.5D or more (if sediment accumulates easily).
20. Suction tank.
21. Screen.
22. Short pipe.

## ■ Suction Piping

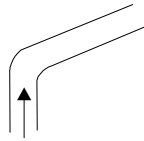
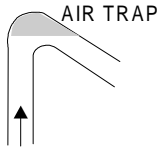
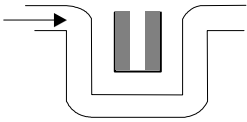
1. The suction pipe should employ the flooded suction method if possible. The shortest pipe possible, with a minimum number of bends, should be designed. Arrange a proper support along the suction pipe so that the load and thermal stress of the pipe itself are not applied to the pump.
2. Attach the coupling on the suction pipe carefully so that no air enters the line. Air in the suction pipe may prevent priming of the pump.
3. If the suction condition is not good (e.g. the suction tank is a vacuum, the suction head is large, or the suction pipe is long), NPSHa should always be at least 2 feet greater than NPSHr. For the NPSHr, refer to the Standard Performance Curve.
4. When a bend is used on the suction side, install a straight pipe which is more than 20 inches long or 10 times as long as the suction port diameter before the suction port of the pump. Use the largest possible radius of curvature for the bend.
5. Do not allow any projection where air may be trapped along the suction pipe. The suction pipe should have an ascending gradient toward the pump.

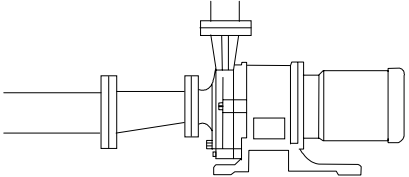
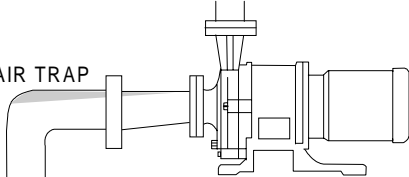
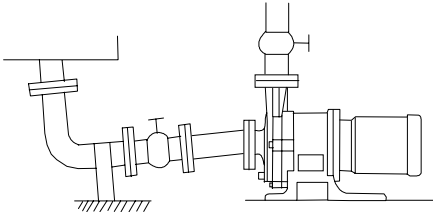
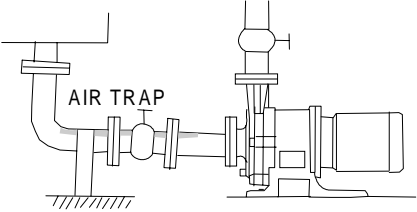
GOOD CONDITIONS	UNACCEPTABLE CONDITIONS
	
	
	
	

6. If the diameters of the pump suction port and suction pipe are different, use an eccentric reducer pipe. Connect the eccentric reducer pipe such that the upper part of it is level. Never use a suction pipe with a diameter smaller than that of the pump suction port.
7. When using the flooded suction method, the suction pipe should be given a slight ascending gradient toward the pump so that no air pocket is created on the suction side.
8. The end of the suction pipe should be located 24 inches or more below the surface of the liquid.
9. A screen should be provided at the inlet in the suction tank to prevent the entry of foreign matter into the suction pipe. Foreign matter may cause malfunctioning of the pump. The end of the suction pipe should be 1~1.5D or more away from the bottom of the suction tank. (D: diameter of suction pipe).
10. When using the suction lift method, install a foot valve on the suction pipe.
11. When using the flooded suction method, it is recommended that a gate valve be installed on the suction pipe to enable easier overhaul inspection of the pump. Since this valve is used only in the overhaul inspection of the pump, keep it fully opened during normal pump operation.
12. Pay close attention to the lowest level of the liquid in the suction tank so that air entrainment to the suction piping will not occur.

The inflow pipe into the suction tank should be distanced from the suction pipe and positioned below the liquid surface level as a means of preventing air entrainment to the suction pipe. If air bubbles are generated in the suction tank, install a baffle.

13. It is recommended to install a vacuum/pressure gauge on the suction piping approximately 6 D from the pump suction flange.

#### ■ Discharge piping.

1. Use proper pipe supports so that the weight of the piping does not load the pump nozzle.
2. If a method other than flooded suction is used, install a special pipe for priming.
3. If the piping is very long, its diameter should be determined by calculating the piping resistance. Otherwise, the specified performance may not be obtained due to increased piping resistance.
4. A check valve should be installed if any of the following conditions exists in the piping:
  - The discharge piping is very long.
  - The discharge head is 50 feet or more.
  - The end of the discharge pipe is 30 feet higher than the surface of the suction tank.
  - Several pumps are connected in parallel with the same piping.

5. The installation of a gate valve on the discharge pipe is recommended for the adjustment of discharge quantity and for the prevention of motor overload. When installing both a check and a gate valve, the check valve should be positioned between the pump and the gate valve.
6. A pressure gauge must be installed on the discharge piping.
7. An air bleeding valve should be installed if the discharge pipe is very long in the horizontal direction.
8. A drain valve should be installed for the drainage of liquid if there is a chance that the liquid in the discharge pipe will freeze.

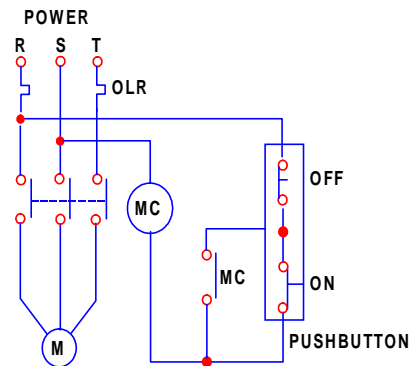

M      MOTOR  
 MC     ELECTROMAGNETIC SWITCH  
 ON }    PUSH BUTTON  
 OFF }  
 OLR    OVERLOAD RELAY

## ■ Wiring

Use appropriate wiring materials and abide by the local and national standards for electrical codes, and the instruction manual of the motor. In addition, follow the instructions given below.

1. Use an electromagnetic switch that conforms to the specifications (voltage, capacity, etc.) of the pump motor.
2. If the pump is installed outdoors, use waterproof wiring to protect the switches from rainwater and moisture.
3. The electromagnetic switch and push button should be installed at a reasonable distance from the pump.
4. Refer to the wiring example shown on the left. This wiring diagram does not include the installation of a dry-operation prevention device. Refer to the instruction manual of the dry-operation prevention device when installing it.
5. If the horsepower of your motor is 7 ½ HP or higher, You can use a motor soft starter if desired.

## 6 Pump Operation

---

### ■ Notes on operation.

1. Never operate the pump dry or with the suction side valve (gate valve) closed. Otherwise, the pump will be damaged.
2. In the event of cavitation, stop the pump immediately.
3. If the magnet coupling decouples, stop the pump within a minute. The power of the magnet coupling will be reduced if operation is continued with the coupling disconnected.
4. Temperature fluctuation should not exceed 176° F throughout the modes of starting, stopping, and operating the pump.
5. Be sure to close the discharge valve completely before starting operation, in order to prevent water hammer upon start-up.
6. The pump should never be operated for a lengthy period with the discharge valve closed. A resultant rise in the temperature of liquid in the pump can cause damage to the pump.
7. In the event of a service power failure during pump operation, turn off the power switch immediately and close the discharge valve.

### ■ Start-Up Preparation

Preparation should be carried out as described below when operating the pump for the first time or restarting operation after a long stoppage.

1. Thoroughly clean the inside of the piping and pump. Supply water.
2. Tighten the flange connecting bolts and base installation bolts. Check the torque of the bolts which couple the liner, casing and the frame together. Proper torque is 58.8N-m (43.4 lb-ft).
3. Use a screwdriver to rotate the motor fan and check that the fan rotates smoothly.

#### Caution

Manually rotate pump drive shaft to ensure ventilation of entrapped air in pump casing. Failure to do so may result in damage to the pump bearing system.

4. After priming the pump, close the discharge valve fully.
5. In the case of flooded suction, measure the pressure in the suction pipe to check that the pump is filled with liquid. Next, rotate the motor fan using a screwdriver, etc., to rotate the pump and remove any air trapped in the impeller section.



6. In the case of the suction lift method, simultaneously carry out priming and rotate the motor fan using a screwdriver, etc., to rotate the pump and remove any air trapped in the impeller section.
7. Run the motor momentarily to check the direction of rotation. The motor should run in the direction indicated by the arrow sealed on the pump. (Clockwise when viewed from the motor fan side.) If the direction is reversed, exchange two wires of the three-phase power wires.

■ **Operation**

Following are details of the pump operation procedure.

	Check/Operation Item	Remarks
1.	Check Valve	Suction valve..fully open Discharge valve..fully closed
2.	Check pump is filled with liquid.	If pump is not filled with liquid, fill it in accordance with steps 5 and 6 of 'Start-up Preparation'.
3.	Turn ON motor switch momentarily and check for correct direction of pump operation.	See the arrow on the casing to confirm the direction of rotation (clockwise when viewed from the motor fan side).
4.	Flow rate adjustment If total discharge pressure is increased to shutoff pressure after achieving normal pump operation, open discharge valve gradually to set discharge pressure as specified.  Pump should be operated observing following discharge quantity. Minimum discharge quantity: 13 gal/min. or more.  In case of automatic control, close discharge valve when starting pump and gradually open discharge valve thereafter.	Open valve carefully, paying attention to ammeter to prevent motor from being overloaded through excessive opening of valve.
5.	Points to be observed during operation. If pump enters continuous operation condition, check flow meter and confirm that pump operation meets specifications.	If flowmeter is unavailable, check values of discharge, suction pressure, and current in relation to piping resistance.

## ■ Stopping Operation

	Check/Operation Item	Remarks
1.	Close discharge valve gradually.	 <b>Caution</b> Do not cause sudden closure by using solenoid valve, etc. Otherwise, pump may be damaged by water hammer.
2.	Stop motor.	Observe whether motor stops rotating slowly and smoothly. If not, check inside of pump.
3.	Points to be observed when stopping pump.  <b>Caution</b> If pump operation is stopped in winter, liquid inside the pump cavity may freeze and damage the pump. Be sure to drain liquid completely. In case of short-term suspension of operation, which does not allow removal of liquid, use band heater, etc., to prevent liquid inside the pump from freezing.  In the event of service power failure, turn OFF power switch and close discharge valve.	

## 7 Maintenance and Inspection

### ■ Daily Inspection

1. Check that the pump operates smoothly, without generating abnormal sounds or vibration.
2. Check the level of the liquid in the suction tank, and the suction pressure.
3. Compare the discharge pressure and motor current measured during operation with the specifications indicated on the motor and pump nameplates to verify whether the pump load is correct.

\* Note that the indicated value of the pressure gauge varies in proportion to the specific gravity of the liquid.

 **Note:**

The valve to the pressure gauge or vacuum gauge on the piping system should be opened only when measurements are recorded. It must be closed after the completion of each measurement. If the valve remains open during operation, the gauge mechanism may be affected by abnormal pressure caused by water hammer, etc.

4. If a spare pump is included in the installation, keep it ready for use by operating it from time to time.

■ **Periodic Inspection**

Inspection Interval	Part Name	Inspection Point	Countermeasure
Every 6 mos. * Inspection record should be maintained.	Outer magnet assembly	Is there scoring?	Contact your distributor if abnormality is observed.
		Is housing mounted normally? Are hexagonal socket setscrews loose?	Reinstall housing on motor shaft and fasten hexagonal socket setscrews.
		Are inner perimeter of magnet and motor shaft concentric? (Max. eccentricity: 1/4 mil.)	Retighten or replace hexagonal socket setscrews.
Every 3 mos. * Inspection record should be maintained.	Containment shell cover	Is there scoring?  Improper installation in frame?	Contact your distributor if abnormality is observed.  Adjust.
	Containment shell cover	Is there scoring on inner diameter?  Are there any cracks?  Gasket, outboard	Contact your distributor if abnormality is observed.  Replace if abnormality is observed.  Replace if part is damaged.
	Inner magnet assembly	Is there scoring in rear section or in cylindrical body?  Are there any cracks in resin of rear section or in cylind. body?  Wear of inboard bearing bushing?	Contact your distributor if abnormality is observed.  Contact your distributor if abnormality is observed.  Check degree of wear. Permissible gap between outboard and inboard bearing bushing diameter is 40 mil (0.04 in)
	Impeller   (continued)	Wear of inboard thrust collar  Degree of warping of vanes.  Are there any cracks?  Is there clogging cavitation?	Check degree of wear and replace if required.  Replace if part is damaged.  Replace if abnormality is observed.  Eliminate cause.

Inspection Interval	Part Name	Inspection Point	Countermeasure
Every 3 mos. * Inspection record should be maintained.	Impeller (continued)	Stain or clogging inside impeller.	Clean.
		Dimensional change of impeller.	Replace if abnormality is observed.
		Clogging in balancing hole.	Clean.
	Casing, liner	Stain in liquid-contacting section.	Clean.
		Are there any cracks?	Replace if abnormality is observed.
		Connection with casing cover (239).	Contact your distributor if abnormality is observed.
Is drain clogged?		Clean.	
Casing, cover	Expansion of gasket or crack in inboard gasket.	Replace if part is damaged.	
	Scoring in inappropriate position.	Contact your distributor if abnormality is observed.	
	Stain in liquid-contacting section.	Clean.	
	Wear of bearing or clogging in liquid passage.	Check degree of wear and replace if necessary.	
Casing, cover	Wear of outboard thrust collar, scoring, or cracking?	Replace if abnormality is observed.	
	Scoring in inappropriate position.	Contact your distributor if abnormality is observed.	

■ **Wear limit of outboard and inboard bearing bushing.**

Part Name		MDE	
		Dimension (inches)	
		New	Upon Replacement
Outboard Bearing bushing	Bore	1.73 in.	1.77 in.
	Thrust face-difference	0.08 in.	0.04 in.
Inboard Bearing bushing	Outer diameter	1.73 in.	1.69 in.
	Thrust face-difference	2.52 in.	2.56 in.

Note:

If the difference between I.D. of the outboard bearing bushing and O.D. of the inboard bearing bushing exceeds 40 mil (0.04 inches), replace the bushing, outboard or inboard, whichever is worn out, with a new one regardless of the value specified in the table.

If abrasion in total exceeds 40 mil (0.04 inches) in thrust face-difference, it also requires replacement.

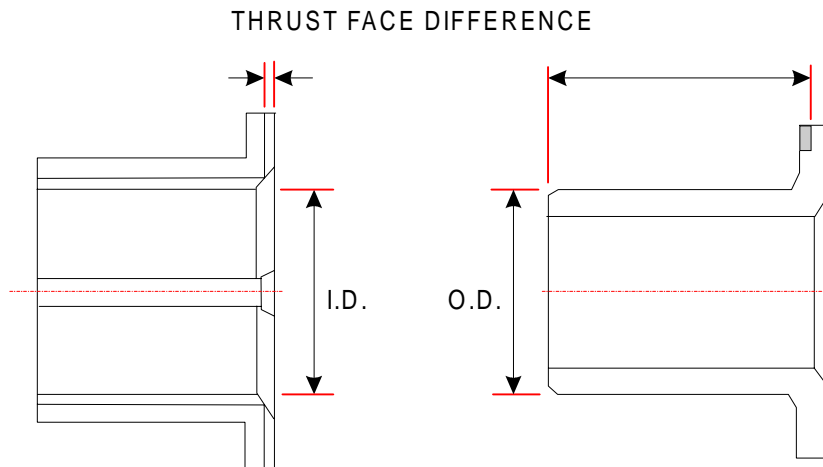

## 8 Troubleshooting Guide

Trouble	Symptom on Pump		Cause	Inspection and Countermeasures
	With Discharge Valve Closed	With Discharge Valve Open		
		Pressure gauge and vacuum gauge indicate 'zero'	<ul style="list-style-type: none"> <li>● Insufficient priming.</li> <li>● Dry Operation</li> </ul>	<ul style="list-style-type: none"> <li>○ Stop pump, feed priming liquid and restart pump.</li> </ul>
	Liquid Level drops immediately when priming is carried out		<ul style="list-style-type: none"> <li>● Foot valve is clogged with foreign matter.</li> </ul>	<ul style="list-style-type: none"> <li>○ Replace strainer.</li> <li>○ Check whether seat is clogged with foreign matter.</li> </ul>
Liquid is not pumped	Liquid level drops if discharge valve is opened after starting operation.	Needles of pressure and vacuum gauges swing but return to zero immediately.	<ul style="list-style-type: none"> <li>● Air enters through suction pipe or gasket section.</li> </ul>	<ul style="list-style-type: none"> <li>○ Check whether connection flange in suction piping is sealed airtight.</li> <li>○ Check whether suction liquid level is abnormally low.</li> </ul>
			<ul style="list-style-type: none"> <li>● Magnet coupling is disconnected.</li> </ul>	<ul style="list-style-type: none"> <li>○ Stop pump and use a screwdriver to check for easy and smooth rotation of motor fan.</li> <li>○ Measure current level to check for low reading.</li> <li>○ Check for foreign matter inside pump cavity.</li> <li>○ Check whether voltage level is normal.</li> </ul>
			<ul style="list-style-type: none"> <li>● RPM of pump is insufficient.</li> <li>● Pump rotation is reversed.</li> </ul>	<ul style="list-style-type: none"> <li>○ Check wiring and motor, and fix as necessary.</li> <li>○ Correct motor wiring.</li> </ul>

Trouble	Symptom on Pump		Cause	Inspection and Countermeasures
	With Discharge Valve Closed	With Discharge Valve Open		
Discharge quantity is small.	Needles of pressure and vacuum gauges indicate normal values.	Needle of vacuum gauge indicates high value.	● Strainer is clogged with foreign matter and liquid passage is blocked.	○ Remove foreign matter in strainer.
		Needle of vacuum gauge indicates abnormally high value.	● Air is trapped in suction pipe.	○ Inspect installation of suction pipe and modify it as necessary.
			● Inlet section of impeller unit is clogged with foreign matter.	○ Partially disassemble unit and remove foreign matter.
		Needles of pressure gauge and vacuum gauge fluctuate.	● Air enters via suction pipe or gasket section.	○ Check flange gaskets of suction pipe and tighten it as necessary.
			● Discharge side of pump is clogged with foreign matter.	○ Remove foreign matter in pump. ○ Remove foreign matter or scale inside of piping.
		Vacuum gauge needle indicates high value while pressure needle indicates normal value.	● Air pocket or resistance in suction pipe.	○ Inspect suction piping installation and make corrective adjustments.
		Pressure gauge needle indicates high value while vacuum gauge needle indicates normal value.	● There is a section in discharge pipe that causes high resistance or actual head and loss of head are too high.	○ Check actual head and piping loss of discharge pipe and take necessary measures.

Trouble	Symptom on Pump		Cause	Inspection and Countermeasures
	With Discharge Valve Closed	With Discharge Valve Open		
Discharge quantity is low.	Needle of pressure gauge indicates low value and vacuum gauge indicates extraordinarily low value.	Needle of pressure gauge and vacuum gauge indicate low value.	<ul style="list-style-type: none"> <li>● Rotating direction of pump/motor is reversed.</li> </ul>	<ul style="list-style-type: none"> <li>○ Correct motor wiring to reverse rotation. (Clockwise when viewed from motor side.)</li> </ul>
Motor overheats			<ul style="list-style-type: none"> <li>● Voltage is insufficient.</li> <li>● Overload.</li> <li>● Ambient temperature is high.</li> </ul>	<ul style="list-style-type: none"> <li>○ Check whether voltage and frequency levels are adequate.</li> <li>○ Check whether specific gravity and viscosity of liquid are above specification.</li> <li>○ Stop pump and use screwdriver, etc., to check whether motor fan rotates easily and smoothly.</li> <li>○ Improve air ventilation.</li> </ul>
Discharge quantity is suddenly lowered.		Needle of vacuum gauge indicates high value.	<ul style="list-style-type: none"> <li>● Strainer is clogged with foreign matter.</li> </ul>	<ul style="list-style-type: none"> <li>○ Remove foreign matter.</li> </ul>

Trouble	Symptom on Pump		Cause	Inspection and Countermeasures
	With Discharge Valve Closed	With Discharge Valve Open		
Pump vibrates.			<ul style="list-style-type: none"> <li>● Foundation is inadequate.</li> <li>● Anchor bolt is loose.</li> <li>● Suction pipe is closed. Cavitation is caused.</li> <li>● Wear or melting of pump bearing.</li> <li>● Damaged inner magnet assembly or pump shaft.</li> <li>● Fluctuating dynamic balance of outer magnet assembly</li> <li>● Impeller is in contact with inner magnet assembly anchoring section.</li> <li>● Wear of motor bearing.</li> </ul>	<ul style="list-style-type: none"> <li>○ Carry out installation process again.</li> <li>○ Retighten bolt.</li> <li>○ Clean, eliminate cause of cavitation.</li> <li>○ Replace.</li> <li>○ Replace.</li> <li>○ Remove or replace.</li> <li>○ Replace bearing or motor.</li> </ul>

# 9 Parts Description and Exploded View

## Close-coupled mounted motor type

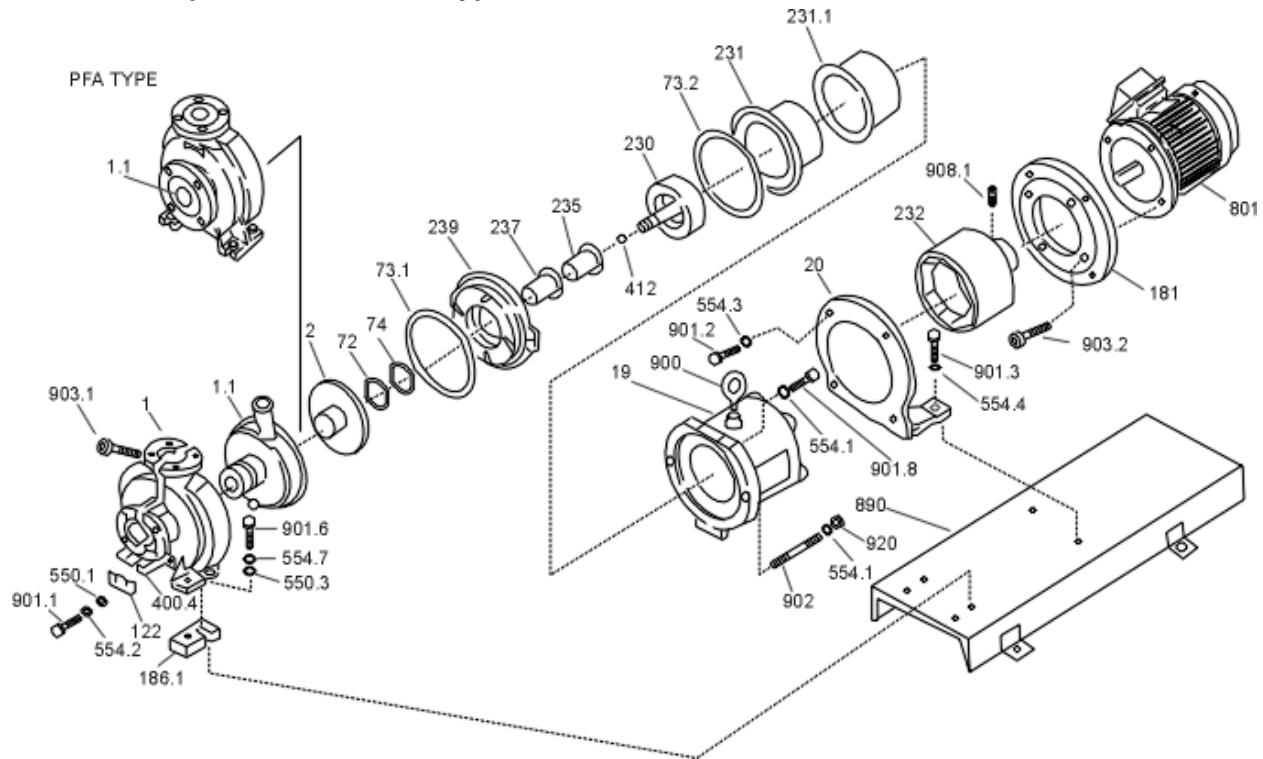

\* In the PFA type, the casing liner is integral with the cover.

No.	Name of Part	Quantity	Material	No.	Name of Part	Quantity	Material	Remarks
1	Casing, Front	1	FCD400	239	Casing Cover	1		See Note 1
1.1	Casing Liner	1	See Note 1	400.4	Drain Gasket	1	PTFE	
2	Impeller	1		412	O-ring	1	Kalrez®	
19	Frame	1	FCD400	550.1	Plate Washer	2	Stainless Steel	5/16
20	Foot support adapter (10hp & smaller)	1		550.3	Plate Washer	2		1/2
72	Inboard Thrust Collar	1	SiC	554.1	Spring Washer	6		1/2 (see note 2)
73.1	Inboard Gasket	1	PTFE	554.2	Spring Washer	2		5/16
73.2	Outboard Gasket	1		554.3	Spring Washer	4		M12
74	Outboard Thrust Collar	1	SiC	554.4	Spring Washer	2		1/2
122	Drain Plate	1	Steel	554.7	Spring Washer	2		1/2
181	Motor adapter (15hp & larger)	1		801	Motor	1		
186.1	Front Spacer	2	Steel	890	Base Plate	1	Steel	
230	Inner Magnet Assy	1	See Note 1	900	Eyebolt	1		1/2" 13UNC
231	Containment Shell	1		901.1	Hex Head Bolt	2	Stainless Steel	5/16" 18UNC x 3/4
231.1	Cont'mnt Shell Cover	1	FRP	901.2	Hex Head Bolt	4		M12 x 40
232	Outer Magnet Assy	1	Rare earth Magnet & steel	901.3	Hex Head Bolt	2		1/2" 13UNC x 1 1/2
235	Inboard Bearing Bushing	1	SiC	901.6	Hex Head Bolt	2		See Note 2
237	Outboard Bearing Bushing	1		901.8	Hex Head Bolt	2		1/2 13UNC x 2 1/2
				902	Stud Head Bolt	2		1/2" 13UNC
				903.1	Hex Socket Head Bolt	5		
				903.2	Hex Socket Head Bolt	4		1/2" 13UNC x 1 1/2
				908.2	Hex Socket Setscrew	2		M8 x 10
				920	Hex Nut	2		1/2" 13UNC

Note 1: Varies depending on pump type.

Note 2: Pump type determines size and quantity.

■ Frame mounted motor type

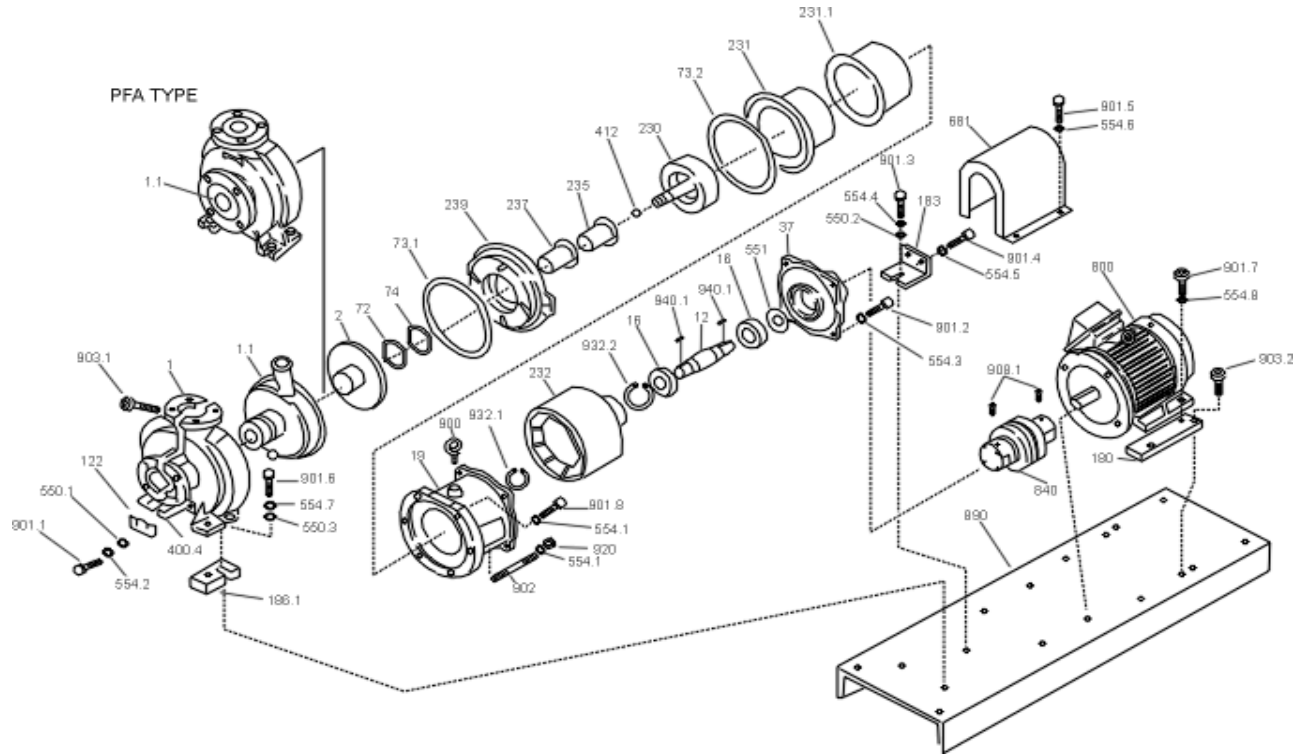

\* In the PFA type, the casing liner is integral with the cover.

No.	Name of Part	Quantity	Material	No.	Name of Part	Quantity	Material	Remarks
1	Casing, Front	1	FCD400	551	Wave Washer	1	Spring Steel	
1.1	Casing Liner	1		554.1	Spring Washer	6		1/2 (see note 2)
2	Impeller	1	See Note 1	554.2	Spring Washer	2	Stainless	5/16
12	Drive shaft	1	Steel	554.3	Spring Washer	4	Steel	M12
16	Inboard Bearing	1	J1SB1512 6308ZZ	554.4	Spring Washer	2		1/2
18	Outboard Bearing	1	J1SB1512 6208ZZ	554.5	Spring Washer	2		3/8
19	Frame	1	FCD400	554.6	Spring Washer	4		5/16
37	Bearing Cover	1	FC200	554.7	Spring Washer	2		1/2
72	Inboard thrust collar	1	SiC	554.8	Spring Washer	4		See Note 2
73.1	Inboard gasket	1	PTFE	681	Coupling Cover	1	Steel	
73.2	Outboard gasket	1		801	Motor	1		
74	Outboard thrust collar	1	SiC	840	Mechanical coupling	1		
122	Drain plate	1		890	Base Plate	1	SS400	
180	Motor spacer	1	Steel	900	Eyebolt	1	Steel	1/2" 13UNC
183	Rear support	1		901.1	Hex Head Bolt	2		5/16" 18UNC x 3/4
186.1	Front spacer	1		901.2	Hex Head Bolt	4		M12 x 40
230	Inner Magnet Assy	1	See Note 1	901.3	Hex Head Bolt	2	Stainless	1/2" 13UNC x 1 1/2
231	Containment Shell	1		901.4	Hex Head Bolt	2	Steel	3/8" 16UNC x 3/4
231.1	Cont'ment Shell Cover	1	FRP	901.5	Hex Head Bolt	4		5/16" 18UNC x 1/2
232	Outer Magnet Assy	1	Rare earth Magnet & Steel	901.6	Hex Head Bolt	2		See Note 2
235	Inboard Bearing Bushing	1	SiC	901.7	Hex Head Bolt	4		See Note 2
237	Outboard Bearing Bushing	1		901.8	Hex Head Bolt	2		1/2 13UNC x 2 1/2
239	Casing Cover	1	See Note 1	902	Stud Head Bolt	2		1/2" 13UNC
400.4	Drain Gasket	1	PTFE	903.1	Hex Socket Head Bolt	5	Steel	
412	O-ring	1	Kalrez®	903.2	Hex Socket Head Bolt	4	Stainless Steel	1/2" 13UNC x 1 1/2
550.1	Plate Washer 5/16	2	Stainless	908.1	Hex Socket Setscrew	2	Steel	M8 x 10
550.2	Plate Washer 1/2	2	Steel	908.2	Hex Socket Setscrew	2		
550.3	Plate Washer	2	1/2	920	Hex Nut	2	Stainless Steel	1/2" 13UNC
				932.1	Retaining Ring	1		
				932.2	Retaining Ring	1	Steel	
				940.1	Key	1		
				940.2	Key	1		

Note 1: Varies depending on pump type.

Note 2: Pump type determines size and quantity.

## 10 Disassembly and Assembly of Pump (Close-Coupled Motor Type)

(In this section, refer to exploded view drawing on page 20 for listing and position of parts)

**⚠ Caution** Since the magnets used in the pump are very powerful, be careful not to let your fingers or hands get caught between them during the disassembly or assembly process. Also, do not allow any electronic device that could be damaged by a strong magnetic field near the magnet unit.

Prior to the disassembly or assembly process, the suction and discharge valves must be closed. The piping and pump may retain some liquid; it is recommended to drain the piping and pump cavity prior to servicing.

**⚠ Caution** If hazardous liquid is used, wear protection and disconnect the piping.

### ■ Disassembly

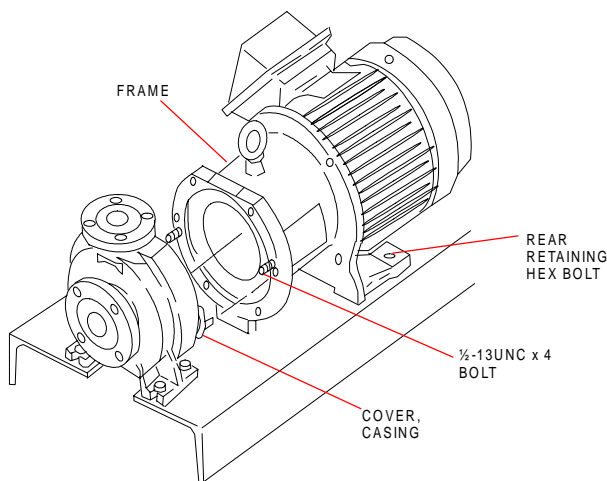
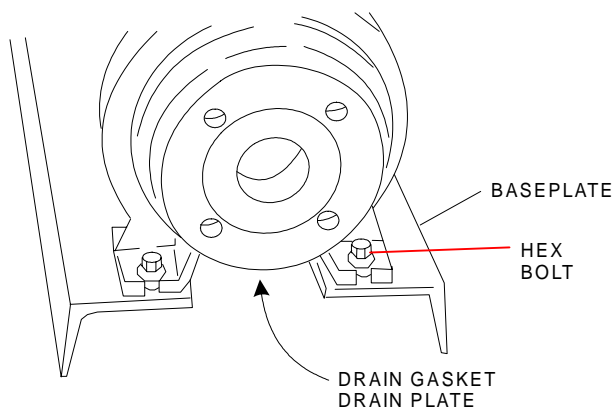

1. Remove the hex bolt (901.1), drain plate (122) and drain gasket (400.4) and drain the liquid out of the casing.

\* If the pump is not equipped with the drain, neutralize the liquid in the casing or wash the casing in water before disassembling.

\* All pump models are equipped with a drain port, however, the customer must specify upon ordering, whether to bore out the port. Consult your distributor for information.

2. Remove the rear retaining hex bolt (901.3) on the frame (19). Then remove the hex bolt (901.8) on the casing liner side as well as the nut (920).
3. Screw the two attached bolts (1/2-3UNC x 4) from the motor side through the tapped hole on the frame (19) to push out the frame (19) so the casing cover (239) is separated from the frame section.

\* Turn the screws alternately. If the frame (19) has been sufficiently driven out, hold it by hand and pull it toward the rear.

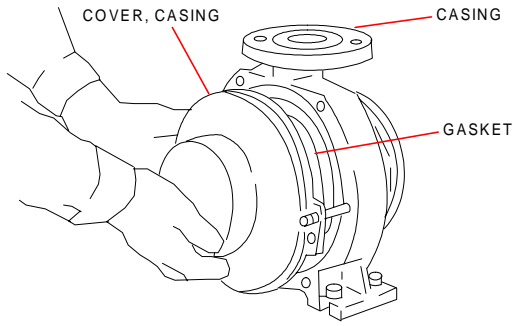

4. Push a flat screwdriver into the gap between the casing cover (239) and the casing (1) to open the sealed section. In this step, be careful not to damage the seal surfaces and inboard gasket (73.1)

5. Remove the impeller (2) from the casing cover (239) and inner magnet assembly (230) by rotating it counterclockwise.

\* Carry out this process carefully since the magnet is very powerful. Also, be careful not to damage the casing liner, casing cover, containment shell, bushing, collar, impeller.

6. Pull the containment shell (231) and shell cover (231.1) out of the frame.

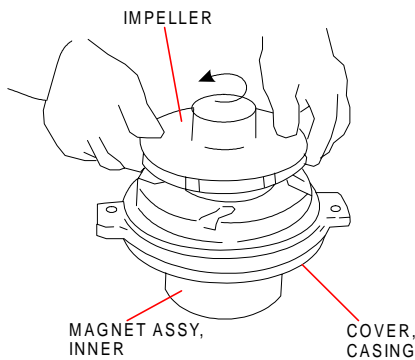

■ **Disassembly and replacement of thrust collar, inboard and outboard bearing bushings.**

*Disassembly and replacement of thrust collar*

1. Remove the worn inboard and outboard thrust collar (72) from the impeller (2) and casing cover (239).

\* The thrust collars are secured to the impeller and the casing cover respectively, by thermoplastic welding. First, heat the welded portions by means of a resin welder or an industrial dryer. Then raise the thrust collar with a flat screwdriver to remove it.

\* In the above step, be careful that the temperature of the resin does not rise excessively. Otherwise, the resin properties will be affected.

2. Insert new inboard and outboard thrust collars into the impeller and casing cover.

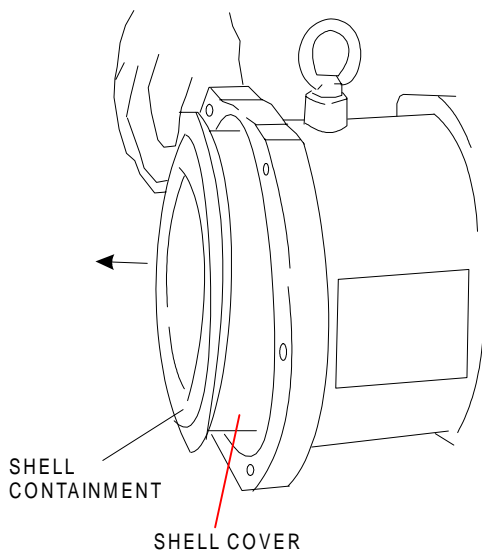

\* To press-fit into impeller:

Press-fit the inboard thrust collar (72) into the impeller only after warming the latter for five minutes in hot water of about 195° F. After press-fitting, wipe off water in the threaded hole of impeller to dry it thoroughly (to prevent rust).

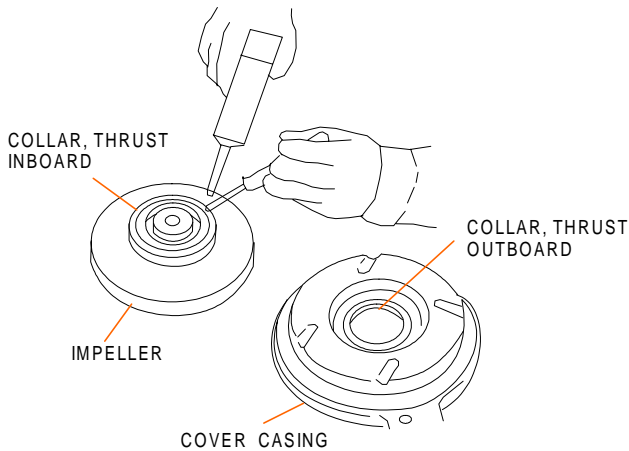

\* Align D-cut section of the thrust bearing with, and press-fit into, the D-cut section of the impeller or the casing cover.

3. Heat the welded part as described in step 1 and push it down into the grooves of the thrust collars to secure the collar as originally.

\*\* Don't detach the thrust collars except when they are to be replaced.

#### *Disassembly and replacement of outboard bearing bushing*

1. Remove the worn outboard bearing bushing (237) from the casing cover (239).

\* The outboard bearing bushing is secured onto the casing cover by thermoplastic welding. Heat the welded part as in step 1 above to remove the outboard bearing bushing from the casing cover.

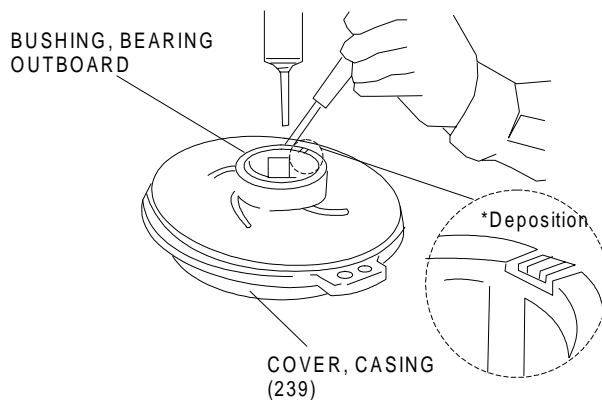

2. Press a new outboard bearing bushing into the casing cover. Heat the welded part again and push it down into the groove to secure as originally.

\* Don't remove the outboard bearing bushing except when it is to be replaced.

\* Deposition:

Deposited resin should not protrude above the thrust surface.

### Disassembly and replacement of inboard bearing bushing

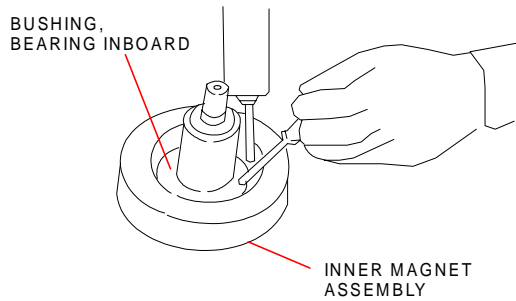

1. Remove the worn inboard bearing bushing (235) from the inner magnet assembly (230).
  - \* The inboard bearing bushing is secured onto the inner magnet assembly by thermoplastic welding. Heat the welded part as in step 1 of 'Disassembly and replacement of thrust collar' to remove the inboard bearing bushing from the inner magnet assembly.
2. Insert a new inboard bearing bushing (235) into the inner magnet assembly (230).
  - \* Heat the welded part again and push it down into the groove in the inboard bearing bushing to secure as originally.
  - \* Don't remove the inboard bearing bushing except when it is to be replaced.

### Disassembly and replacement of casing liner.

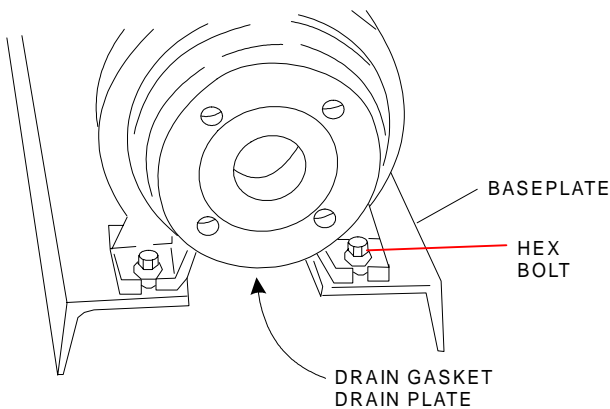

1. Remove the drain plate (122) and drain gasket (400.4).
2. Remove the hex socket head bolts (903.1) and part the casing (1) in two directions to remove it. If the casing does not come off easily due to stains or rust on it, knock it lightly with a plastic hammer, or pry apart using a flat head screwdriver.

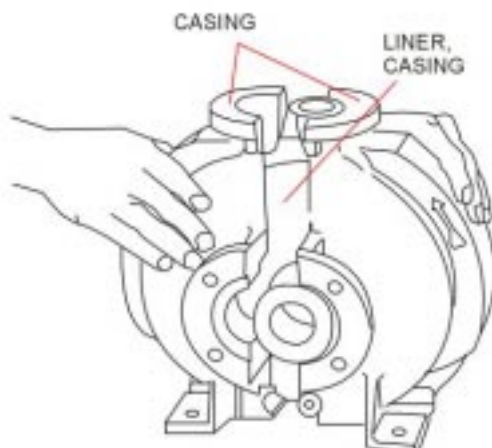

\* The casing is divided into a pair of right and left sections. A single set consists of a right and a left section.

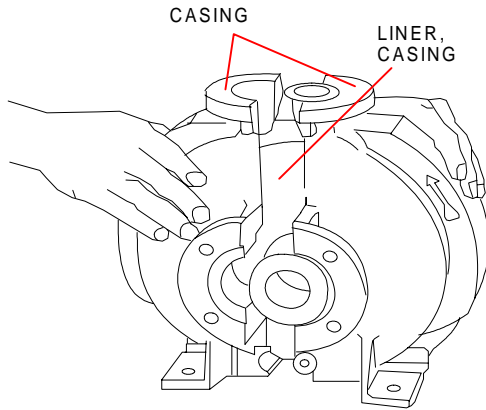

3. Attach the casing (1) to the new casing liner (1.1), being careful about the position of the drain port. Use a hex socket head bolt (903.1) to secure the part temporarily.

- \* If the casing cannot be attached in place, knock it lightly with a plastic hammer such that the seal section of the casing liner will not be damaged.

- \* The PFA casing liner is integrated into a single unit with the casing. It is not possible to replace the casing liner alone.

4. When attaching the casing onto the casing liner, be careful not to misalign it vertically or horizontally. Secure the cover by firmly tightening the hex socket bolts (903.1).

- \* Be sure not to damage the casing and/or liner in this step.

- \* The casing is not supposed to be removed except for replacement of casing liner.

5. Install the drain plate (122) and drain gasket (400.4).

Clamping torque: 9.8 N.m (7.3 lb-ft).

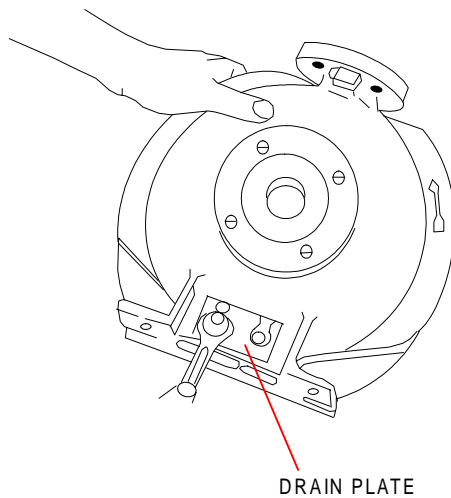

■ **Assembly** (Refer to the exploded view drawing on pg 20 for parts and locations.)

The pump should be assembled by carrying out the steps for disassembly in reverse, as described below.

Keep the sliding and sealed parts clean so that they are free of dust or scratches. When assembling these parts, be sure to attach them in the correct positions.

Fasten the various bolts evenly. Since the magnet is extremely powerful, make sure there are no iron particles adhered to it before installing it.

When reassembling, always use new gaskets and new O rings.

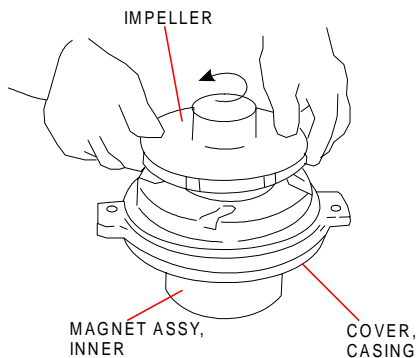
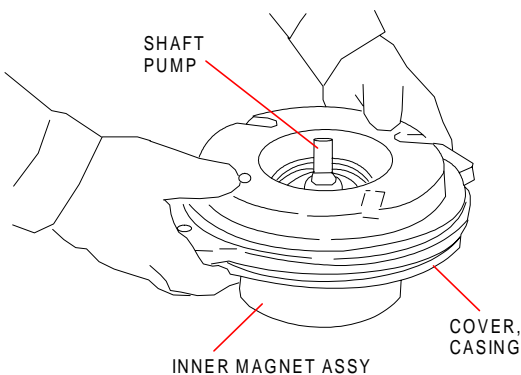
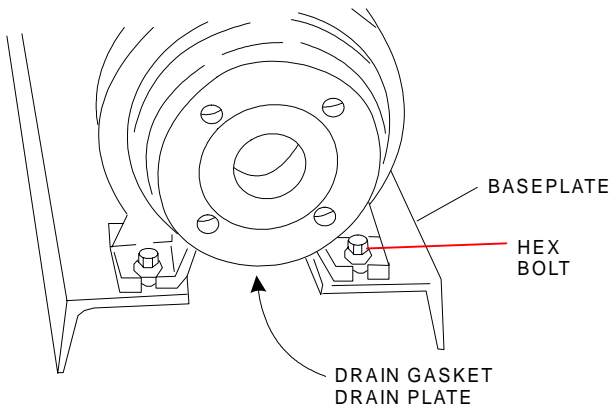

1. Install the prepared casing on the base plate and tighten it temporarily.

2. Install the casing cover (239) from the pump shaft side of the inner magnet assembly (230). Be careful not to damage the inboard bearing bushing or the sliding section of the outboard bearing bushing. Next, attach the O ring (412) to the inner magnet assembly (230) pump shaft, and after applying a proper quantity of adhesive to the threaded portion [three peripheral threads on the threaded portion of the pump shaft], screw the impeller (2) onto the shaft firmly, using a belt wrench to secure it to the proper torque. Tighten impeller (2) to a torque value of 320 in-lbs (370 kgf-cm). Recommended adhesive: Loc-Tite™ No. 242 or an equivalent.

\*\* If adhesive sticks to the O ring or O ring groove, wipe it off immediately.

\*\* Confirm that there is a play of 0.04 to 0.08 inch on the direction of thrust between the casing cover and the impeller.

\*\* Avoid rotating finished assembly as bushing surfaces may be damaged due to dry contact or shock.

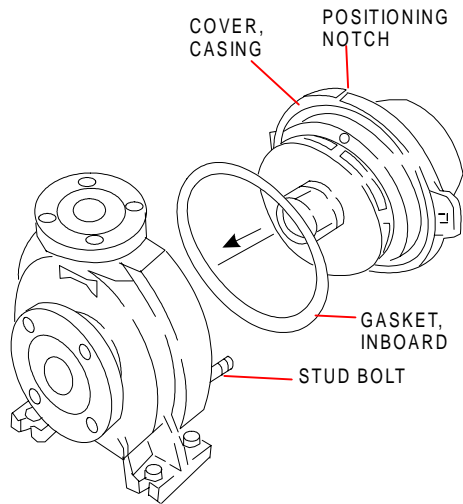

3. Insert the inboard gasket (73.1) into the casing liner (1.1) and install the casing cover (239).
  - \* Screw the stud bolts (902) into the two screw holes in the casing (1). Then, guide the casing cover (239) along the stud bolt with the positioning notch of the casing cover (239) at the top.

4. Install the containment shell cover (231.1) and containment shell (231) onto the frame (19). Next, insert the outboard gasket (73.2) on the recess provided by the containment shell.
  - \* Previously fit, the bolt ( $\frac{1}{2}$  - 13UNC x 4) provided for frame installation should be fully screwed into the maximum depth.

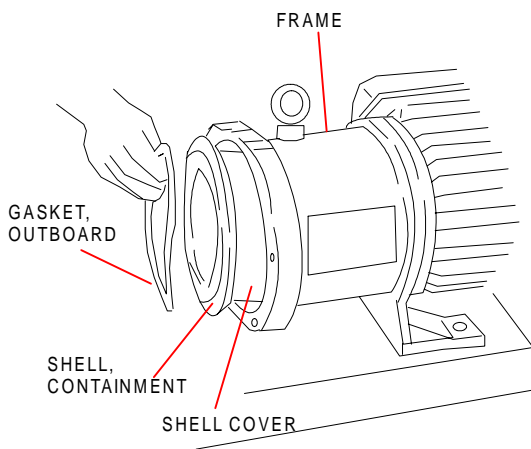

**CAUTION**  
 IF THIS BOLT IS NOT USED, THE INNER MAGNET ASSEMBLY IS QUICKLY ATTRACTED BY THE MAGNETIC FORCE OF THE OUTER MAGNET, WHICH CAN CAUSE DAMAGE TO THE INTERNAL COMPONENTS OF THE PUMP.

5. Direct the frame precisely vertical to the casing (1) on the baseplate and guide it along the stud bolt (902). Loosen the attached bolts ( $\frac{1}{2}$  - 13UNC x 4) alternately to pull the frame slowly forward, until it finally mates onto the casing and stud bolts (902).

**CAUTION**  
 WHEN ASSEMBLING, BE CAREFUL NOT TO LET YOUR FINGERS OR HAND GET CAUGHT BETWEEN THE FRAME (11), CASING (1) AND CASING COVER (239).

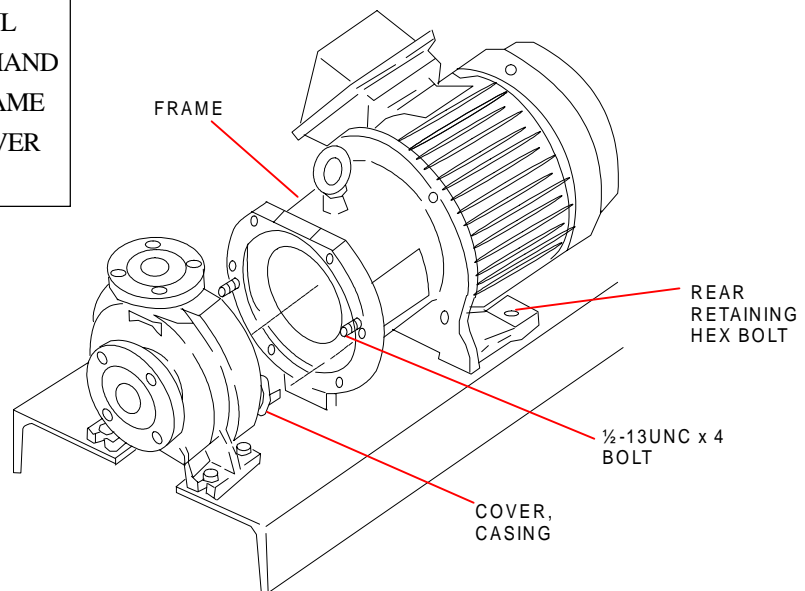

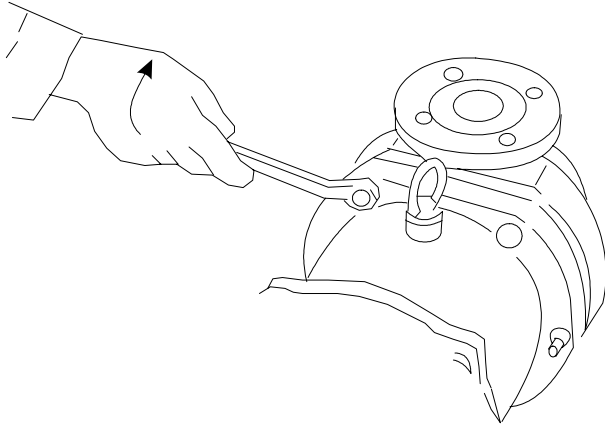

6. Secure the frame firmly with the casing liner by tightening both the hex bolts (901.8) and hex nuts (920). Tighten these bolts diagonally to apply an even torque. Required clamping torque: 58.8 N-m (43.4 lb-ft).

\* At regular intervals, increase the clamping of the parts which secure the frame to the casing. Clamp them only after the hex head bolt (901.3) is loosened from the baseplate.

7. After the frame is properly secured to the casing, tighten the hex bolts (901.3) to secure the frame to the baseplate.

# 11 Disassembly and Assembly of Pump (Frame Mounted Motor Type)

Refer to the exploded view drawing on pg 21 for parts and locations.

Be careful not to get your fingers or hands caught between the magnets during the disassembly or assembly process. Also, do not allow any electronic device that could be damaged by a strong magnetic field near the magnet unit.

Prior to disassembly or assembly, the suction and discharge valves must be closed. The piping and the pump may retain some liquid. If hazardous liquid is used, wear protection and disconnect the piping. It is recommended to drain the piping and pump cavity prior to servicing.

## ■ Disassembly

1. Remove the hex bolts (901.1) and drain plate (122) and drain the liquid out of the casing.
  - \* If the pump is not equipped with the drain, neutralize the liquid in the casing or wash the casing in water before disassembling.
  - \* All pump models are equipped with a drain port, however, the customer must specify upon ordering, whether to bore out the port. Consult with your distributor for information.

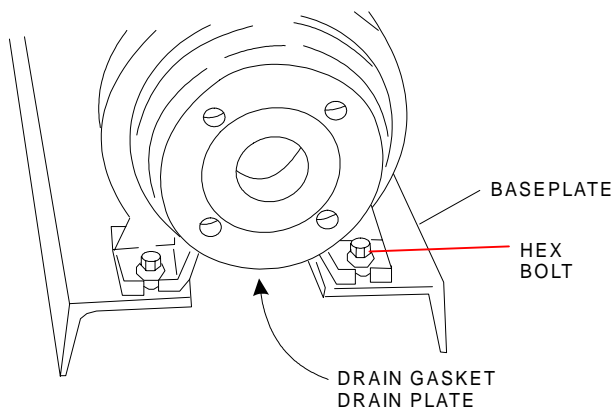

2. Remove the coupling cover bolts (901.5) and detach the coupling cover (681). Next remove the mechanical coupling and rubber sleeve.

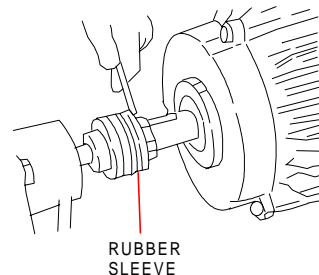
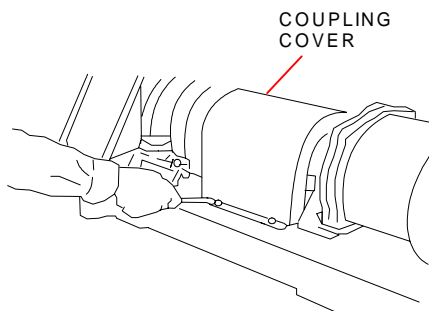

3. Remove the hex head bolts (901.3) which secure the rear support (183) of the bearing cover (37). Then remove the hex head bolts (901.8) and the nuts (920) on the casing side.

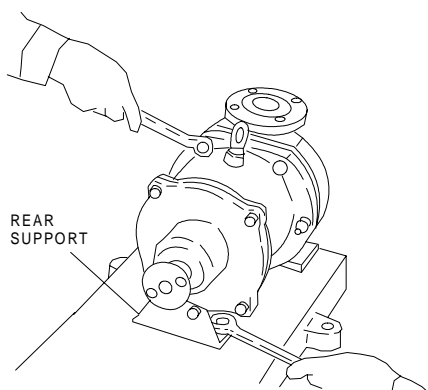

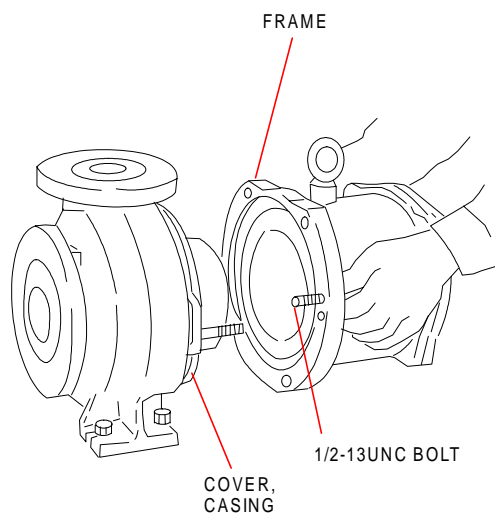

4. Screw the two attached bolts (1/2 - 13 UNC x 4) from the motor side through the screw hole on the frame (19) to push the frame away from the casing cover (239) until they are separated from each other.

\* Turn the screws alternately. If the cover frame (19) has been sufficiently pushed back, hold the frame by hand and pull it toward the rear.

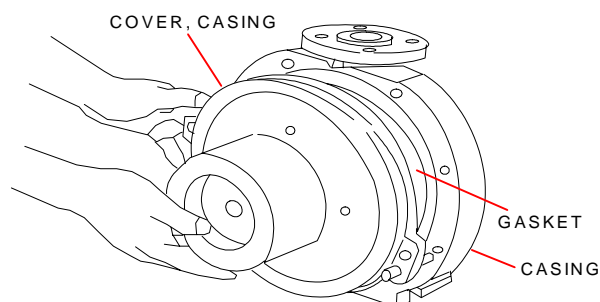

5. Push a flat screwdriver into the gap between the casing cover (239) and casing (1) to open the sealed section. In this step, be careful not to damage the seal surfaces and inboard gasket (73.1).

6. Remove the impeller (230) from the casing cover (239) and inner magnet assembly (230) by rotating it counterclockwise. Remove the impeller using a belt wrench after securing the inner magnet assembly.

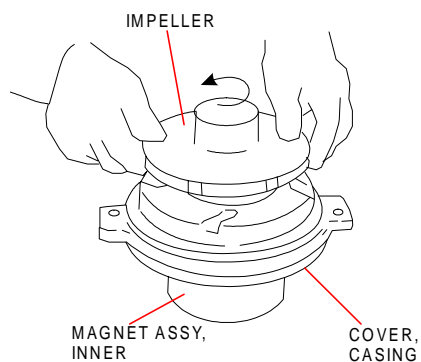

\* Keep in mind the power of the magnet. Also, be careful not to damage the casing liner, casing cover (239), containment shell, inboard bearing bushing, inboard and outboard thrust collars, impeller, etc.

7. Remove the containment shell (231) and shell cover (231.1) from the frame (19).

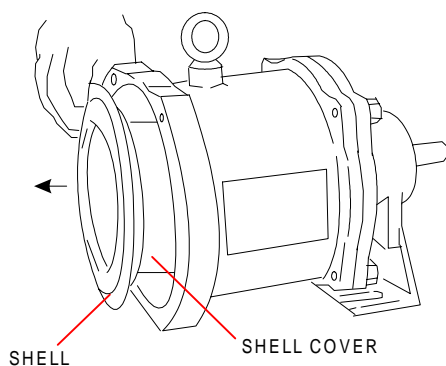

■ **Disassembly and replacement of inboard and outboard thrust collars and bearing bushings.**

*Disassembly and replacement of thrust collars*

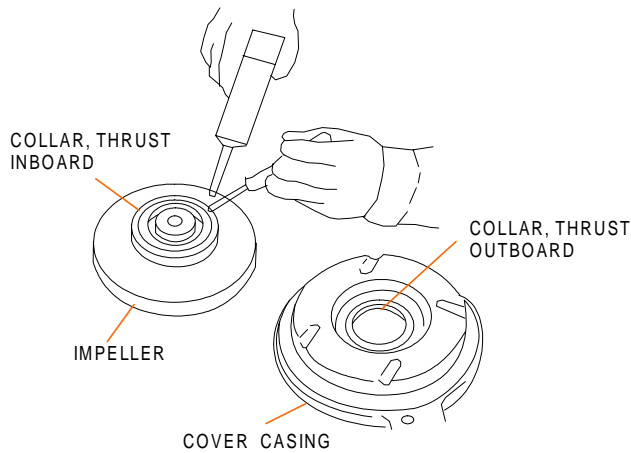

1. Remove the worn thrust collars (72 and 74) from the impeller (230) and casing cover (239).
  - \* The thrust collars are secured to the impeller and the casing cover respectively by thermoplastic welding. First, heat the welded portions by means of a resin welder or an industrial dryer. Then raise the thrust collar with a flat screwdriver to remove it.
  - \* In the above step, be careful that the temperature of the resin does not rise excessively. Otherwise, the resin properties will be affected.

2. Insert new thrust collars respectively into the impeller and casing cover.

\* To press-fit into impeller:

Press-fit the inboard thrust collar into the impeller only after warming the latter for five minutes in hot water of about 195° F. After press-fitting, wipe off water in the threaded hole of impeller to dry it thoroughly (to prevent rust).

\* Align D-cut section of the thrust collar with, and press-fit into the D-cut section of the impeller or the casing cover.

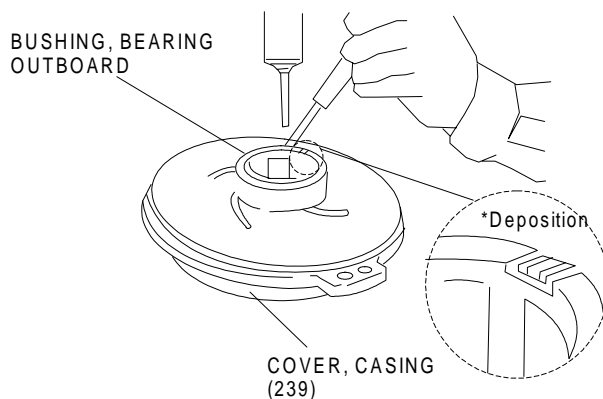

3. Heat the welded part as described in step 1 above and push it down into the groove of the thrust collar to secure the collar as originally.
  - \*\* Don't detach the thrust collar except when it is to be replaced.

\* Deposition:

Deposited resin should not protrude above the thrust surface.

### *Disassembly and Replacement of Outboard Bearing Bushing*

1. Remove the worn outboard bearing bushing (237) from the casing cover (239).
  - \* The outboard bearing bushing is secured onto the casing cover by thermoplastic welding. Heat the welded part as in step 1 of 'Disassembly and replacement of thrust collar' to remove the outboard bearing bushing from the casing cover.
2. Insert a new outboard bearing bushing into the casing cover.
  - \* Heat the welded part again to push it down into the groove to secure as originally.

### *Disassembly and Replacement of Inboard Bearing Bushing*

1. Remove the worn inboard bearing bushing (235) from the inner magnet assembly (230).
  - \* The inboard bearing bushing is secured onto the inner magnet assembly by thermoplastic welding. Heat the welded part as in step 1 of 'Disassembly and replacement of thrust collar' to remove the inboard bearing bushing from the inner magnet assembly.
2. Insert a new inboard bearing bushing into the inner magnet assembly (230).
  - \* Heat the welded part again to push it down into the groove in the inboard bearing bushing to secure it as originally.

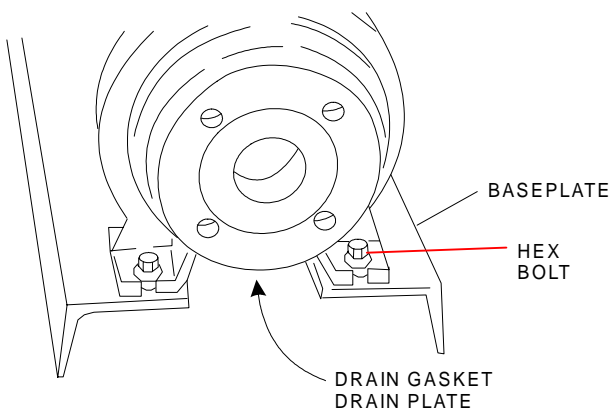
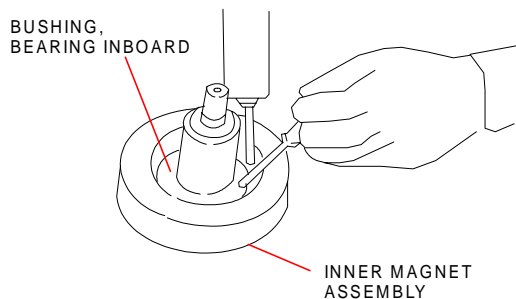

### *Disassembly and Replacement of Casing Liner*

1. Remove the drain plate (122) and drain gasket (400.1).
2. Remove the hex socket head bolts (903) and part the casing (1) in two directions to remove it. If the casing does not come off easily due to

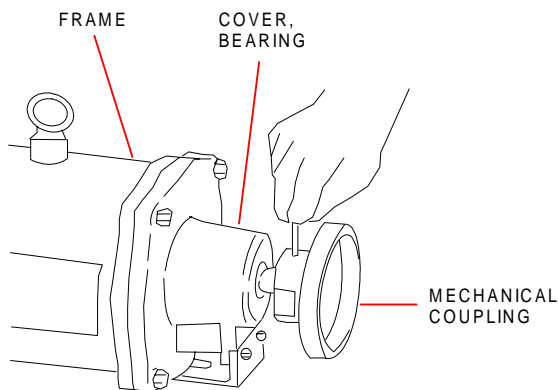
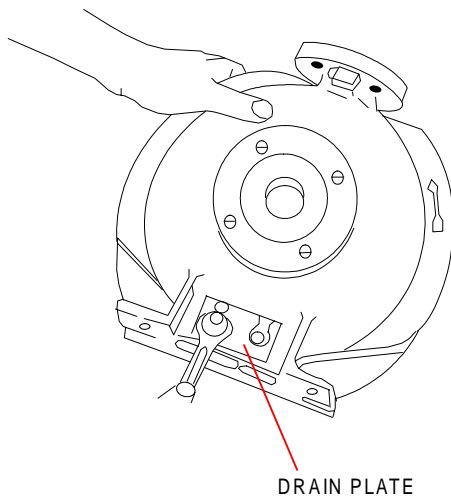
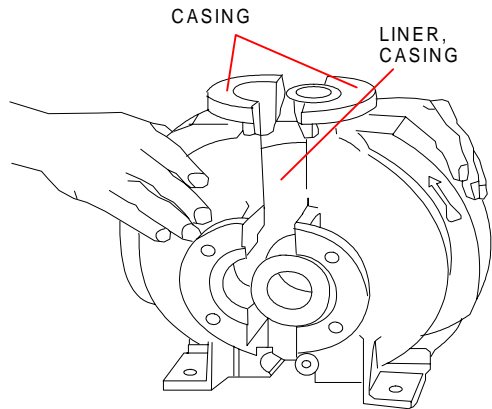

stains or rust on it, knock it lightly with a plastic hammer or pry apart using a flat head screwdriver.

- \* The casing is divided into a pair of right and left sections. A single set consists of a right and a left section.

- \* The PFA casing liner is integrated into a single unit with the cover. It is not possible to replace the casing alone.

3. Attach the casing (1) to the new casing liner (1.1), being careful about the position of the drain port. Use a hex socket head bolt (903) to secure the part temporarily.

- \* If the casing cannot be attached in place, knock it lightly with a plastic hammer such that the rear section of the casing liner will not be damaged.

4. When attaching the cover onto the casing liner, be careful not to misalign it vertically or horizontally. Secure the casing by firmly tightening the hex socket bolts (903).

- \* Be sure not to damage the casing and/or liner in this step.

- \* The casing is not supposed to be removed except for replacement of liner casing.

5. Install the drain plate (122) and drain gasket (400.4).

### *Disassembly and Replacement of Bearing Cover*

1. Remove the hex bolts (901.2) to separate the frame (19) from the bearing cover (37).

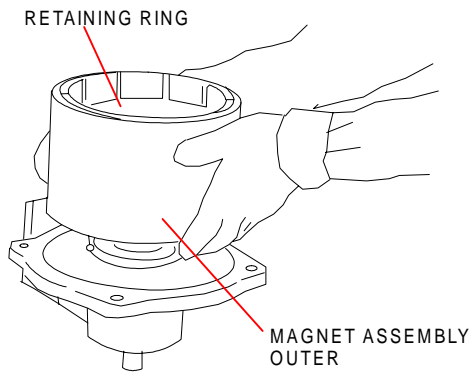

2. Remove the retaining ring (932.1) from the outer magnet assembly (232) and then remove the outer magnet assembly from the drive shaft.

3. Remove the retaining ring (932.2) and the mechanical coupling. Then, remove the drive shaft (12) using an arbor press. Inspect the shaft and bearings for any abnormality. If necessary, replace the parts.

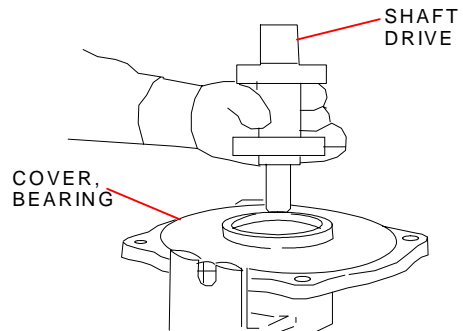
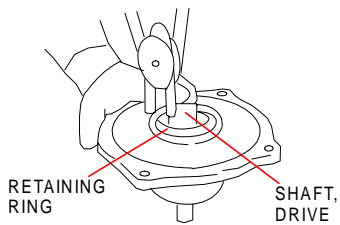

*Assembly*

1. Assembly should be carried out by following the steps for disassembly in reverse.

\* Remember to insert the wave washer (551) when inserting the drive shaft (12) into the bearing cover (37).

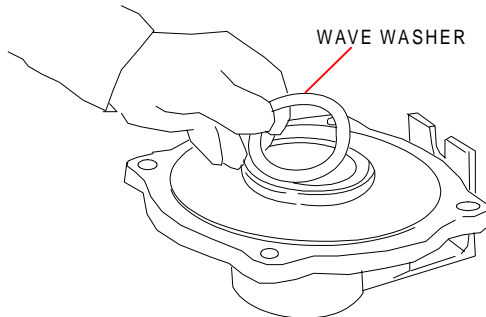

## ■ Assembly

The pump should be assembled by following the steps for disassembly in reverse, as described below. Refer to the exploded view drawings on pages 20-21 for parts and locations.

Keep the sliding and sealed parts clean so that they are free of dust or scratches. When assembling these parts, be sure to attach them in the correct positions. Fasten the various bolts evenly. Since the magnet is extremely powerful, make sure there are no iron particles adhered to it before installing it.

When reassembling, always use new gaskets and new O rings.

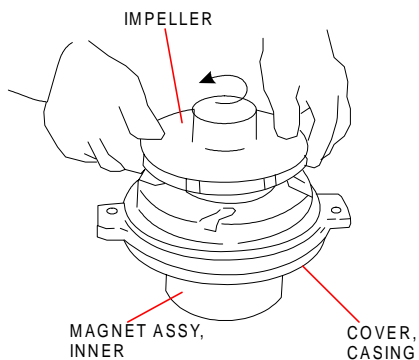
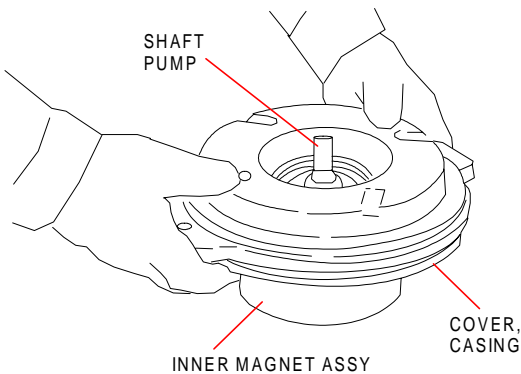
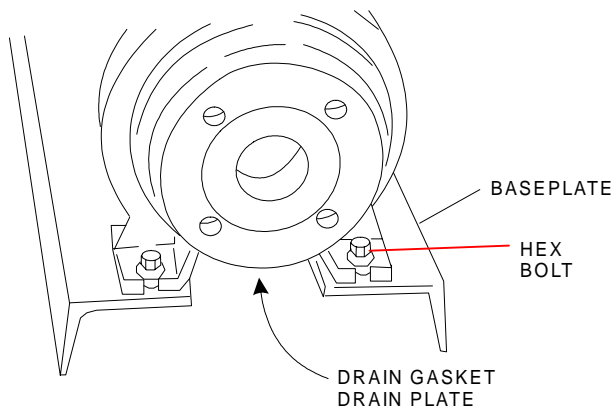

1. Install the prepared casing on the base plate and secure it temporarily.
2. Install the casing cover (239) from the pump shaft side of the inner magnet assembly (230). Be careful not to damage the inboard bearing bushing (235) or the sliding section of the outboard bearing bushing (237).
3. Next, attach the O ring (412) to the inner magnet assembly (230) and after applying a proper quantity (just enough so as not to drip) of adhesive to the threaded portion (three peripheral threads on the threaded portion of the pump shaft), screw the impeller (2) onto the shaft firmly using a belt wrench to secure it to the proper torque. Tighten impeller to a torque value of 320 in-lbs (370 kgf-cm). Recommended adhesive: Loc-Tite™ No. 242 or an equivalent.

\*\* If adhesive sticks to the O ring or O ring groove, wipe it off immediately.

\*\* Confirm that there is a play of 0.04 to 0.08 inches on the direction of thrust between the casing cover and the impeller.

\*\* Avoid rotating finished assembly as bushing surfaces may be damaged due to dry contact or shock.

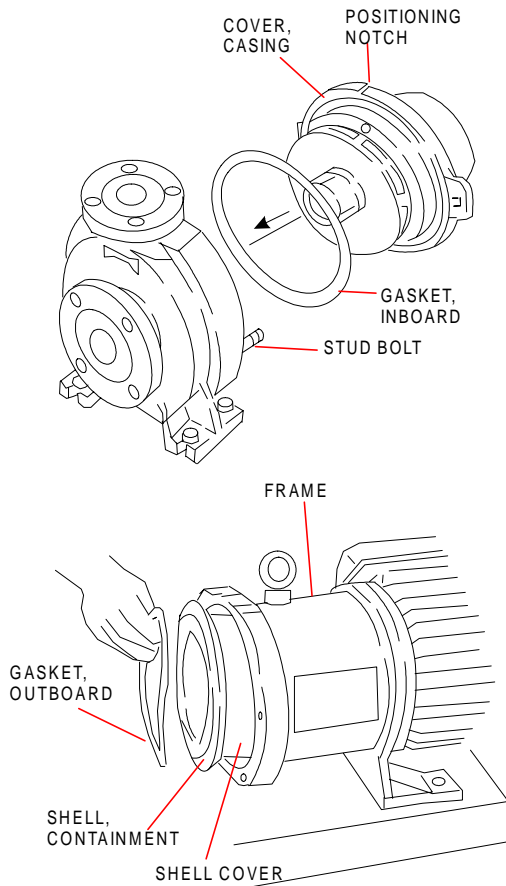

4. Insert the inboard gasket (73.1) into the casing liner (1.1) and install the casing cover (239).
  - \* Screw the stud bolts (902) into the two screw holes in the casing liner. Then, guide the casing cover along the stud bolt with the positioning notch of the casing cover at the top.
5. Install the containment shell cover (231.1) and containment shell (231) onto the frame (19). Next, insert the outboard gasket (400.2) on the recess provided by the containment shell.
  - \* The ½ - 13 UNC x 4 bolt should be mounted in the frame in advance. The bolt should be screwed into maximum depth.

**CAUTION**

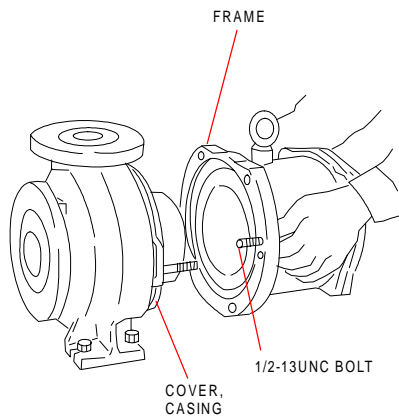

  
 IF THESE BOLTS ARE NOT USED, THE INNER MAGNET ASSEMBLY IS QUICKLY ATTRACTED BY MAGNETIC FORCE OF THE OUTER MAGNET, WHICH CAN CAUSE DAMAGE TO THE INTERNAL COMPONENTS OF THE PUMP.



6. Direct the frame precisely vertical to the casing liner on the base plate and guide it along the stud bolt (902). Loosen the attached bolts (½ - 13UNC) alternately to pull the frame slowly forward, until it finally mates onto the casing liner and stud bolts (902).

**CAUTION**

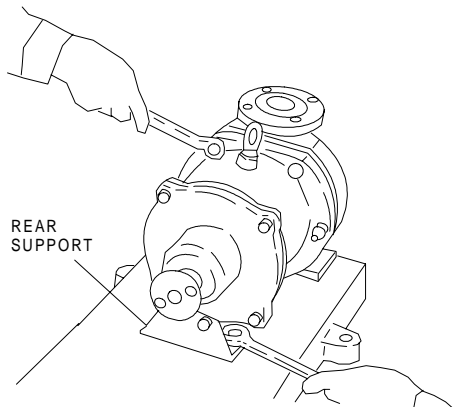
  
 WHEN ASSEMBLING, BE CAREFUL NOT TO LET YOUR FINGERS OR HAND GET CAUGHT BETWEEN THE FRAME AND CASING.



7. Secure the frame firmly with the casing liner by tightening both the hex bolts (901.8) and hex nuts (920). Tighten them diagonally to apply an even torque.
  - Clamping torque: 58.8 N-m (43.4 lb-ft).

\* At regular intervals, increase the clamping of the parts which secure the frame to the casing liner. Clamp them only after the hex head bolt (901.3) is loosened from the baseplate.

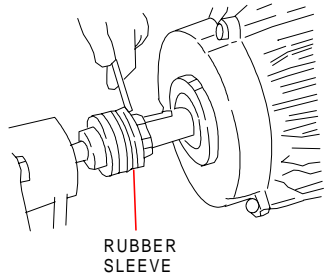

8. After the rear support (183) is attached to the base, connect the pump to the motor by means of the coupling.

9. Adjust the centering of the coupling so as to fall in the following ranges.

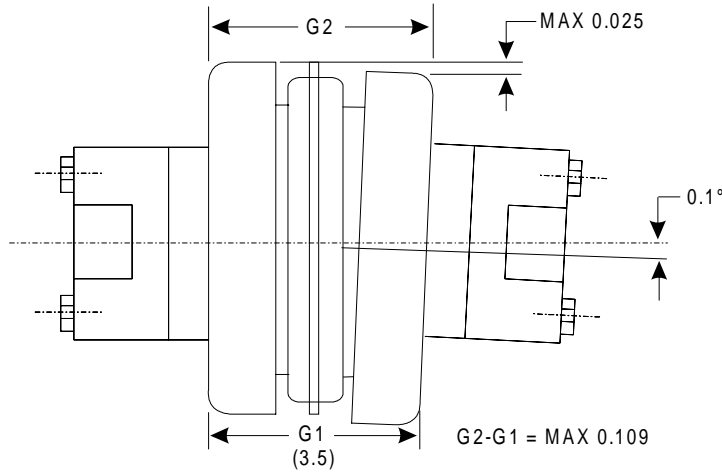

10. After centering adjustment, mount the coupling guard onto the baseplate.

11. Size "H" is given as reference to make sure that 232 is set in place.

Pump Model	Motor		H Dimension Inches
	HP	Frame	
F05	5	184TC	6.102
F07	7.5	213TC	6.102
F10	10	215TC	6.102
F15	15	215TC	6.102
F15S1	15	254TC	7.402
F20	20	256TC	7.402
F25	25	284TSC	7.402

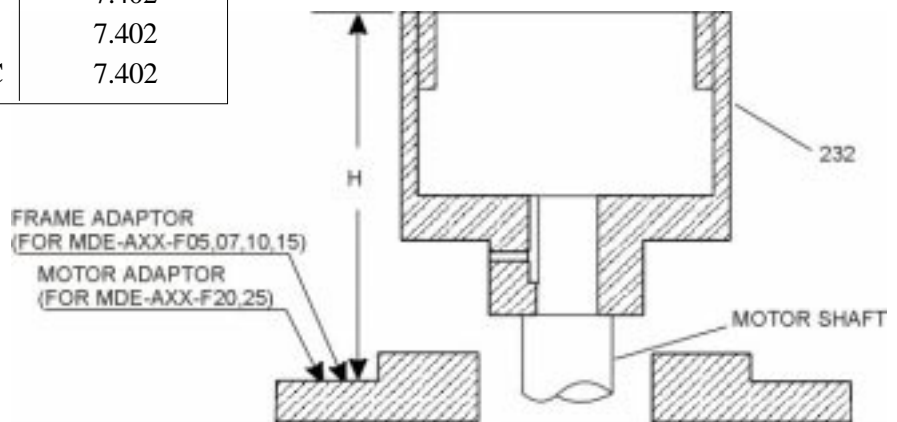

## 12 Spare Parts

Appropriate spare parts are necessary to ensure continuous operation of the pump over a long time. Consumable parts, in particular, should always be kept on hand. When placing orders, supply the following information:

1. Name of part and part number (according to this instruction manual).
2. Pump model number and serial number (as indicated on the nameplate of the pump).
3. Drawing number if you have received the Approved Drawing.

### ■ MDE Part Number List

No.	Part Name	Material	MDE-AA6	MDE-AA8	MDE-AB6
72	Inboard thrust collar	SiC	MEA0513		
74	Outboard thrust collar				
235	Inboard bearing bushing		MEA0522		
73.1	Inboard gasket	PTFE	MEA0516		
73.2	Outboard gasket		MEA0517		
400.4	Drain gasket		MEA0506		
412	O-ring	Kalrez®	MEA0523		
237	Outboard bearing bushing	SiC	MEA0515		

# 13 External Dimensions and Weights

## Close-coupled Mounted Motor Type

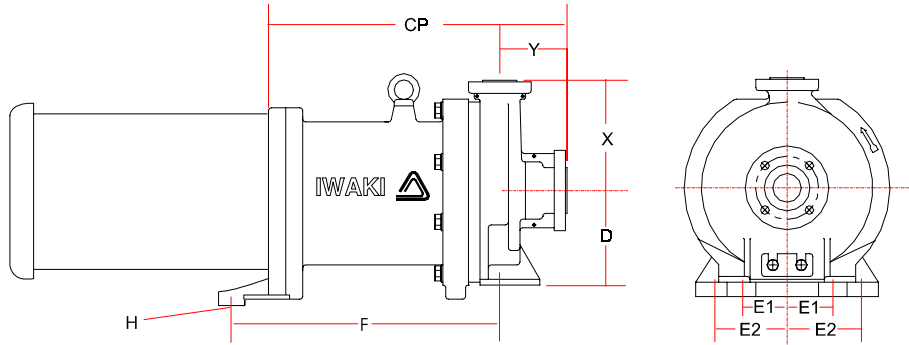

Close Coupled Units (5-15 HP)

Pump Dimensions inches (mm)

Model	Size	X	D	E1	E2	CP	F	H	Y
MDE-AA6	1.5 x 1.0 x 6	6.50	6.28	3.00	4.33	15.09	14.08	0.63	4.00
MDE-AB6	3 x 1.5 x 6	(165.1)	(159.5)	(76.0)	(110.0)	(383.4)	(357.6)	(15.9)	(101.6)
MDE-AA8	1.5 x 1.0 x 8								

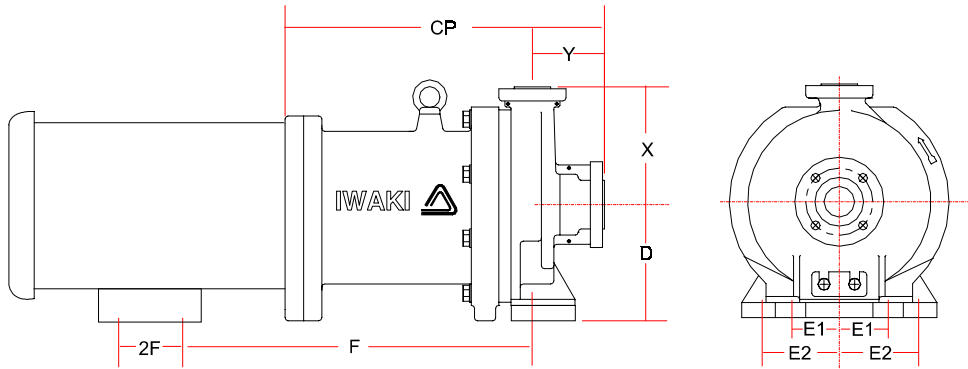

Close Coupled Units (20 HP)

Pump Dimensions inches (mm)

Model	Size	X	D	E1	E2	CP	F	2F	H	Y
MDE-AA6	1.5 x 1.0 x 6	6.50	6.28	3.00	5.00	15.08	15.33	10.00	0.63	4.00
MDE-AB6	3 x 1.5 x 6	(165.1)	(159.5)	(76.0)	(127.0)	(383.0)	(389.3)	(254.0)	(15.9)	(101.6)
MDE-AA8	1.5 x 1.0 x 8									

Close Coupled Units (25 HP)

Pump Dimensions inches (mm)

Model	Size	X	D	E1	E2	CP	F	2F	H	Y
MDE-AA6	1.5 x 1.0 x 6	6.50	6.28	3.00	5.50	15.55	16.30	9.50	0.63	4.00
MDE-AB6	3 x 1.5 x 6	(165.1)	(159.5)	(76.0)	(139.7)	(394.9)	(413.9)	(241.3)	(15.9)	(101.6)
MDE-AA8	1.5 x 1.0 x 8									

Close Coupled (w/ outer magnet installed) Weight lbs (kg)

Motor HP	Model			Weight
	MDE-AA6	MDE-AB6	MDE-AA8	
5.0	156 (70.9)	159 (72.3)	166 (75.5)	
7.5	154 (70.0)	158 (71.8)	168 (76.4)	
10.0	156 (70.9)	162 (73.6)	170 (77.3)	
15.0	162 (73.6)	169 (76.8)	175 (79.5)	
20.0	163 (74.1)	168 (76.4)	174 (79.1)	
25.0	165 (75.0)	170 (77.3)	176 (80.0)	

■ **Frame Mounted Motor Type**

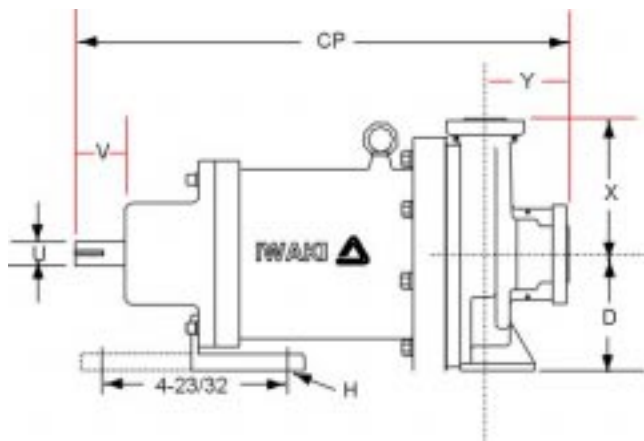
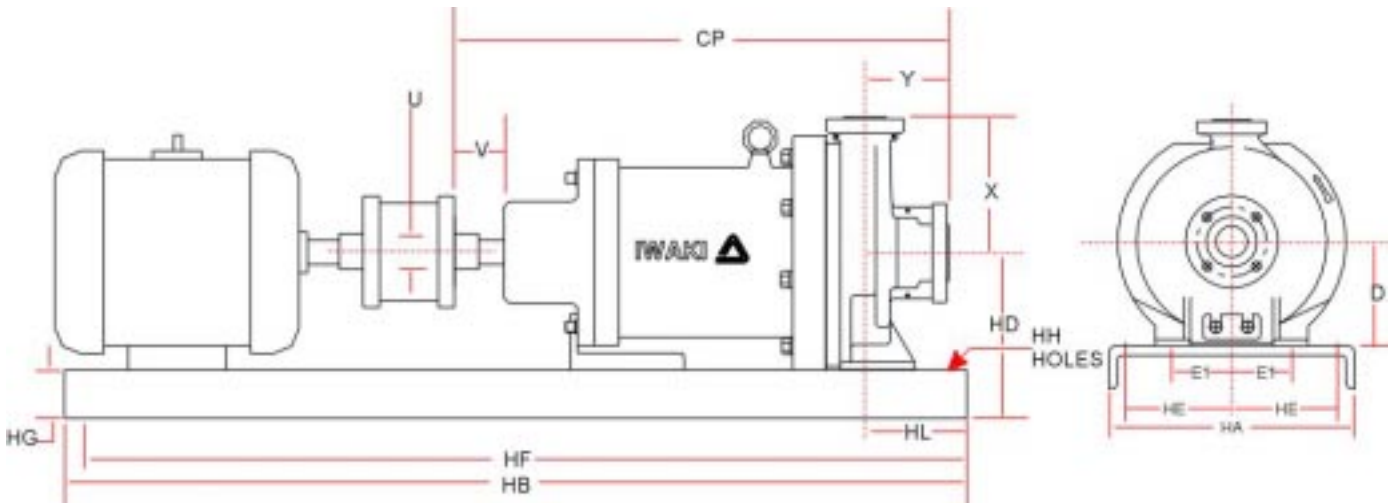

**Pump Weights lbs. (kg.)**

Motor HP	Model		
	MDE-AA6	MDE-AB6	MDE-AA8
5.0	133 (60.5)	140 (63.6)	148 (67.3)
7.5	134 (60.9)	141 (64.1)	149 (67.7)
10.0	137 (62.3)	144 (65.5)	151 (68.6)
15.0	140 (63.3)	147 (66.8)	156 (70.9)
20.0	140 (63.6)	147 (66.8)	158 (71.8)
25.0	143 (65.0)	150 (68.2)	160 (72.7)

**Pump Dimensions**

inches (mm)

Model	Size	X	D	E1	CP	F	H	U	V	Y
MDE-AA6	1.5 x 1.0 x 6	6.50	5.25	3.00	17.50	7.25	0.63	0.875	2.06	4.00
MDE-AB6	3 x 1.5 x 6	(165.1)	(133.4)	(76.0)	(444.5)	(184.2)	(15.9)	(22.2)	(52.4)	(101.6)
MDE-AA8	1.5 x 1.0 x 8									

**Baseplate Mounting Dimensions**

inches (mm)

Baseplate	Max. MotorFrame	HA	HB	HD	HE	HF	HG	HH	HL	HP	Weight lbs (kg)
139	184T	15.00 (381.0)	39.00 (990.6)	9.00 (228.6)	4.50 (114.3)	36.50 (927.1)	3.75 (95.3)	0.75 (19.1)	4.50 (114.3)	1.25 (31.8)	135 (61.2)
148	215T		48.00 (1219.2)	10.00 (254.0)	6.00 (152.4)	45.50 (1155.7)					167 (75.7)
148	256T										

---

5 BOYNTON ROAD HOPPING BROOK PARK HOLLISTON, MA 01746 USA  
TEL: 508-429-1440 FAX: 508-429-1386 E-MAIL: IWAKIWALCHEM@IWAKIWALCHEM.COM  
ON THE INTERNET AT: WWW.IWAKIWALCHEM.COM



***IWAKI WALCHEM  
MAGNETIC DRIVE PUMP  
MDE SERIES  
INSTRUCTION MANUAL***



**IWAKI WALCHEM Corporation**

Thank you for having selected an Iwaki Walchem MDE Series magnetic-drive pump. This instruction manual deals with the correct handling, maintenance, inspection, and troubleshooting procedures for the MDE magnetic drive pump. Please read through it carefully to ensure the optimum performance, safety and long service of your pump.

## Contents

Item	Page
1. Unpacking and Inspection .....	1
2. Identification .....	2
3. Specifications .....	3
4. Handling Instructions .....	4
5. Installation, Piping and Wiring .....	5
6. Pump Operation .....	10
7. Maintenance and Inspection .....	12
8. Troubleshooting Guide .....	16
9. Parts Description and Exploded View .....	20
10. Disassembly and Assembly of Pump (close-coupled motor type) .....	22
11. Disassembly and Assembly of Pump (frame mounted motor type) .....	30
12. Spare Parts .....	39
13. External Dimensions and Weights .....	40