



***IWAKI AMERICA  
MAGNETIC DRIVE PUMP  
MDIWMD SERIES***



Thank you for having selected an Iwaki America MD/WMD Series magnetic drive pump. This instruction manual deals with the correct handling, maintenance, inspection and troubleshooting procedures for the MD/WMD magnetic drive pump. Please read through it carefully to ensure the optimum performance, safety and long service of your pump.

## Contents

1	SAFETY INSTRUCTION.....	1
2	UNPACKING AND INSPECTION .....	3
3	OPERATING PRINCIPLE.....	3
4	MODEL IDENTIFICATION GUIDE.....	4
5	SPECIFICATIONS.....	5
	Construction/Materials.....	6
6	HANDLING INSTRUCTIONS.....	7
7	INSTALLATION, PIPING, AND WIRING .....	8
	7.1 Installation.....	8
	7.2 Piping instructions .....	9
	7.3 Wiring.....	9
8	ASSEMBLY.....	11
9	OPERATION.....	12
10	MAINTENANCE/INSPECTION AND CONSUMABLE PARTS.....	14
11	PARTS DESCRIPTION AND EXPLODED VIEW.....	14
12	DIMENSIONS .....	15
13	TROUBLESHOOTING.....	16

# 1 SAFETY INSTRUCTIONS

---

## ***Turn off the power supply***

Working without disconnecting the power supply may cause an electrical shock. Before performing any assembly or maintenance procedures involving the pump, make sure to turn the power supply switch off and to stop the pump and other related devices.

## ***Terminate operation***

When you detect any signs of abnormal operation, terminate pump operation immediately.

## ***For specified application only***

The use of a pump in any applications other than those clearly specified may result in injury or damage to the pump. Use the pump strictly in accordance with the pump specifications and application capabilities.

## ***Modification***

Never modify the pump. Iwaki America will not be responsible for any accident or damage of any kind caused by the user remodeling the pump without first obtaining permission or instructions from Iwaki America.

## ***Protective clothing***

If application involves the handling of hazardous liquids, protective gear (gloves, glasses, clothing, etc) must be worn before performing any maintenance on the pump. Please follow safety guidelines established for such applications.

## ***Operation***

Operation of the pump and related system must be by experienced or knowledgeable personal. The pump operator or pump operation supervisor must not allow any personal who have little or no knowledge of the pump to operate the unit.

## ***Power***

Do not operate the pump at a different voltage than specified on the nameplate. This may result in damage to the unit or fire. Only the specified voltage must be used.

## ***Do not submerge***

If the motor or power cable becomes wet or damp fire or electric shock may occur. The unit should be installed in such a manner to prevent contact with fluids or in a wet environment. Follow all local, state and government regulations for the installation and wiring of the pump.

## ***Spill accident***

Protective measures should be taken against any accidental spill or leakage of any hazardous liquids as a result of unexpected damage to the pump or the related piping. Please follow safety guidelines established for such occurrences.

## ***Operating site must be free of water and humidity***

The pump is not designed to be water-proof or dust-proof. The use of the pump in places with splashing water or humidity above 90% may result in an electrical shock or short circuit.

***Do not damage power cord***

Do not cut, abrade or forcibly pull the power cord. Excessive heat or heavy load applied to the cable may damage the cable and finally result in a fire or an electrical shock.

***Do not cover the motor***

Covering the motor during operation may result in an accumulation heat inside the motor and cause a fire or a mechanical failure. Proper ventilation is necessary for the motor.

***Grounding***

Do not operate the pump without proper grounding; otherwise an electrical shock may result. Follow all local, state and government regulations for the installation and wiring of the pump.

***Power cord cannot be replaced***

Never use a damaged power cable; otherwise, a fire or an electrical shock may result. Handle the power cord carefully, as it cannot to be replaced by a new cable. (The complete motor must be replaced if damaged).

***Location and storage***

Do not install or store the pump in the following places:

- \* Places where a flammable gas or material is used or stored.
- \* Places where the ambient temperature is extremely high (104°F or higher) or extremely low (32°F or lower).

***Static Electricity Hazard***

When low electric conductivity liquid such as ultra-pure water is handled, static electricity may be generated in the pump, which may cause static discharge and damage the pump. Take appropriate countermeasures to avoid and remove any potential static electricity.

## 2 UNPACKING AND INSPECTION

Iwaki Magnet Pump 		
MODEL _____		
MAX. CAPACITY	ℓ /min	_____
MAX. HEAD	m	_____
SINGLE PHASE (1φ) INDUCTION MOTOR CAPACITOR-RUN		
POLES	SPEED	rpm
VOLTAGE	V RATING	CONT.
FREQUENCY	Hz	CAPACITOR
POWER CONSUMPTION	W	INSULATION CLASS E
OUTPUT	W	THERMALLY PROTECTED
CURRENT	A	INDOOR
<b>⚠ DO NOT RUN PUMP DRY</b>		
MFG.No. _____		
<b>IWAKI CO.,LTD.</b> TOKYO JAPAN		

IWAKI MAG DRIVE PUMP 		
MODEL _____		
MAX. CAPACITY	GAL/MIN	_____
MAX. HEAD	FT.	_____
VOLTAGE	AMPS	_____
SERIAL NO. _____		
IWAKI AMERICA 5 BOYNTON ROAD HOPPING BROOK PARK HOLLISTON, MA 01746 USA TEL: 508-429-1440 www.iwakiamerica.com		

Open the package and check that the product conforms to your order. Also, check each of the following points. For any problem or inconsistency, contact your distributor at once.

1. Check that the model number indicated on the nameplate conforms to the specifications of your order.
2. Check that all the accessories you ordered are included.
3. Check that the pump body and parts have not been accidentally damaged or that any bolts have not been loosened in transit.

## 3 OPERATING PRINCIPLE

A sealless magnet drive pump uses magnet torque to transmit energy from the motor to the impeller. A magnet coupling is formed using an inner, or driven magnet, attached to the impeller and an outer, or drive magnet, attached to the motor shaft. This design eliminates mechanical shaft seals or packing, since there is no direct connection between the motor shaft and the impeller. The front and rear casings, sealed with a static o-ring, form the pump or liquid end. The magnetic field is transmitted from the drive magnet through the rear casing to the driven magnet that is attached to the impeller. The combined coupling torque of the drive magnet and impeller magnet provides the driving power to the fluid being pumped.

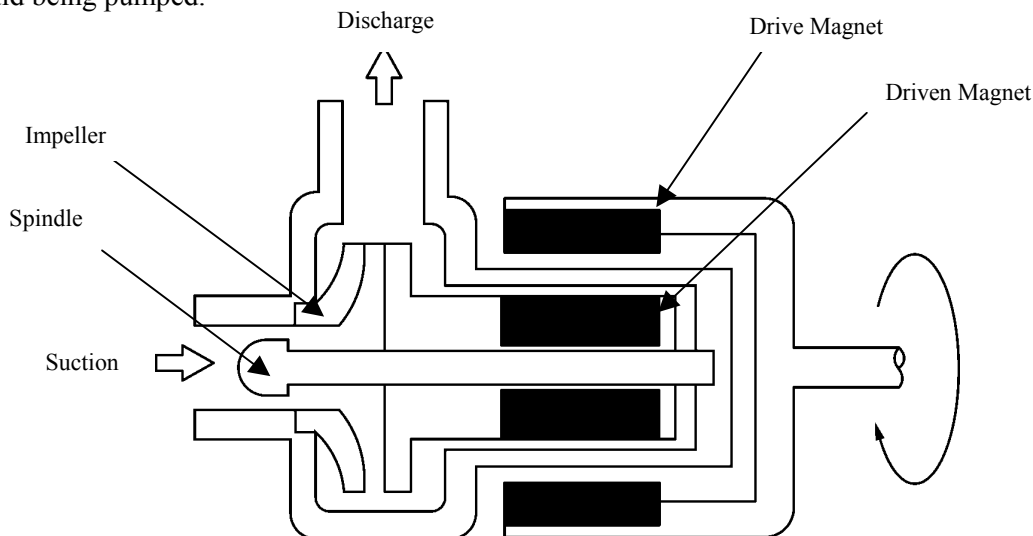

## 4 MODEL IDENTIFICATION GUIDE

---

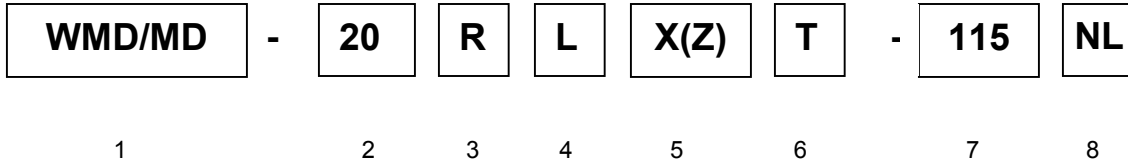

- 1. Series name (WMD specifies US motor design)**
- 2. Pump Size (6, 10, 15, 20, 30, 55, 70, 100)**
- 3. R = Rotating Spindle (omit for MD-6 and MD-10)**
- 4. L = UL Listed Motor, included in 6, 10, 55, 70, 100 115V model**  
(also on older 15/20/30/40 models)
- 5. Pump type**  
Blank: Standard Impeller  
Z: High Head Impeller  
X: High Flow Impeller
- 6. Suction/Discharge Port Connections**  
Blank: Hose Connection  
T: Threaded Connection
- 7. Power source voltage:**  
115: 115V (50/60Hz)                      230: 230V (50/60Hz)  
220: 220/240V(50/60Hz)
- 8. NL = UL Listed 115V Motor (applies to 15, 20, 30, 40 sizes)**

## 5 SPECIFICATIONS

Model	Connections		Motor Output (HP)	Motor Speed (RPM)	Current (Amps)	Max Flow (GPM)	Max Head (Ft)	Max Sys. Pressure (PSI)	Specific Gravity	Weight (Lbs)
	Hose	NPT								
<b><i>Polypropylene</i></b>										
MD-6	1/2	---	1/250	3100	0.25	2.3	4.5	2.80	1.2	1.8
MD-10	1/2	---	1/125	2900	0.40	3.1	6.8	4.30	1.1	1.6
MD-15R(T)	1/2	1/2	1/75	3100	0.29	5.0	11.1	7.20	1.3	3.5
WMD-15R(T)	1/2	1/2	1/75	3100	0.82	5.0	11.1	7.20	1.3	6.0
MD-20RT(T)	5/8	3/4	1/38	3100	0.48	8.2	14.1	9.95	1.1	4.4
WMD-20R(T)	5/8	3/4	1/38	3100	0.48	8.2	14.1	9.95	1.1	7.0
MD-20RX(T)	1	1	1/38	3100	0.50	13.7	8.2	5.69	1.3	4.4
WMD-20RX	1	1	1/38	3100	0.50	13.7	8.2	5.69	1.3	7.0
MD-20RZ	5/8	3/4	1/38	3100	0.53	2.9	22.6	14.22	1.1	4.4
WMD-20RZ	5/8	3/4	1/38	3100	0.53	2.9	22.6	14.22	1.1	7.0
MD-30R	3/4	3/4	1/16	3150	0.80	10.0	17.7	11.60	1.3	7.7
WMD-30R	3/4	3/4	1/16	3150	1.00	10.0	17.7	11.60	1.3	9.0
MD-30RX	1	1	1/16	3150	1.10	19.0	13.5	8.54	1.1	7.7
WMD-30RX	1	1	1/16	3150	1.00	19.0	13.5	8.54	1.1	9.0
MD-30RZ	5/8	3/4	1/16	3150	1.10	4.5	36.1	24.18	1.0	7.7
WMD-30RZ	5/8	3/4	1/16	3150	1.00	4.5	36.1	24.20	1.0	9.0
MD-40R	3/4	3/4	1/12	3200	1.30	13.7	21.3	14.22	1.1	8.6
WMD-40R	3/4	3/4	1/12	3200	1.90	13.7	21.3	14.22	1.1	10.0
MD-40RX	1	1	1/12	3200	1.20	22.4	15.4	9.95	1.1	8.6
WMD-40RX	1	1	1/12	3200	1.90	22.4	15.4	9.95	1.1	10.0
MD-55R	1	1	1/8	3400	1.60	18.4	26.9	17.06	1.2	10.1
MD-70R	1	1	1/4	3400	2.80	25.6	31.8	21.33	1.0	13.2
MD-70RZ	3/4	3/4	2/7	3400	3.80	11.4	66.6	42.70	1.0	13.2
MD-100R	1	1	1/3	3300	3.40	35.6	39.0	25.60	1.2	18.7
WMD-100R	1	1	1/3	3400	*	35.6	39.0	25.60	1.2	*
<b><i>Fluoroplastic</i></b>										
WMD-30FX	---	1/2	1/16	3200	0.9	3.2	35.2	17.0	1.3 (1.5)	9
WMD-30FY	---	1/2	1/16	3200	0.9	3.2	26.0	17.0	1.5 (1.8)	9
WMD-30FZ	---	1/2	1/16	3200	0.9	2.6	24.0	21.3	1.9 (2.1)	9
MD-55Y	---	1	1/8	3300	1.9	17.1	25.6	21.3	1.3 (1.5)	11.9
MD-55Z	---	1	1/8	3300	1.6	13.0	19.0	21.3	2.0 (2.2)	11.9
WMD-100FY	---	1	1/3	3450	*	36.0	38.0	31.2	1.3 (1.6)	*
MD-100FY	---	1	1/3	3300	3.4	35.7	37.7	31.2	1.3 (1.6)	18.7
WMD-100FZ	---	1	1/3	3450	*	28.0	27.2	31.2	1.9 (2.2)	*
MD-100FZ	---	1	1/3	3300	3.4	28.0	27.2	31.2	1.9 (2.2)	18.7

### Notes:

1. Pump performance data is based on pumping clean water at ambient temperature.
2. The maximum flow rate is at 0 discharge head.
3. Maximum viscosity of liquid: 1.0 cP (for a specific gravity of 1.0)
4. Permissible liquid temperature: 32-176°F (0 – 80°C). Note, permissible temperature range may differ depending upon the type of liquid and operating conditions.)
5. The maximum specific gravity of the liquid is the value at max. flow rate. The value varies depending on the flow rate, ambient temperature, viscosity of liquid, etc.
6. Motor: Single-phase capacitor-run induction motor or 3-phase induction motor.

\* Built-in thermal protector

A thermal protector is built in the motor. The protector automatically stops motor operation when the motor is overheated. (The motor starts again when the temperature falls to normal.)

## Typical Construction/Materials

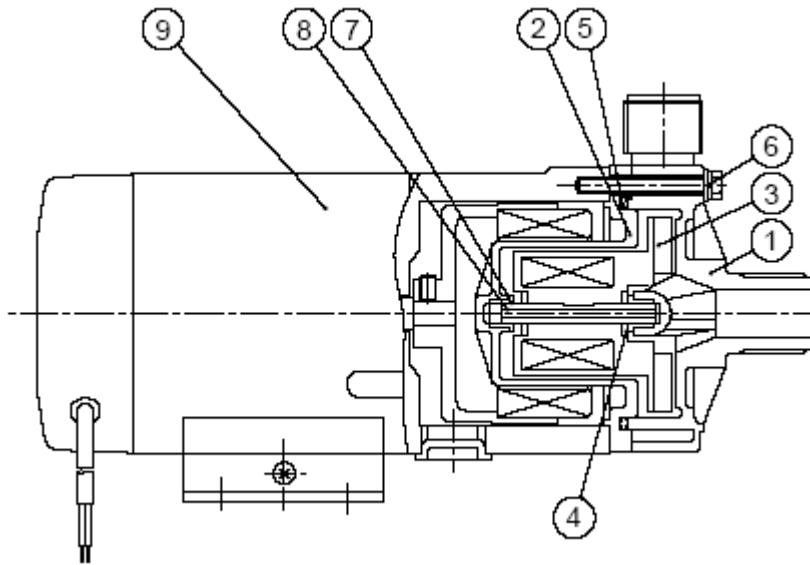

No.	Part Name	Qty	Material
1	Front Casing	1	GFRPP (Note 1)
2	Rear Casing	1	
3	Impeller	1	
4	Thrust	2	Alumina Ceramic
5	O-ring	1	FKM or EPDM (Note 2)
6	Screw	4~6	Stainless steel
7	Bearing	2	Fluororesin containing filler material (Note 3)
8	Spindle	1	Alumina ceramic
9	Motor	1	

Note 1: The material of the impeller used in MD-70RZ, 100R, 100R-5 is CFRPP.

Note 2: More elastomer options available

Note 3: The material of the bearing used in (W)MD-20RZ, 30RZ, and MD-70RZ is PPS.

## 6 HANDLING INSTRUCTIONS

---

### 1. Handle the pump carefully

Strong impact to the pump assembly may result in damage or reduced performance.

### 2. Starting

Before priming the pump be sure the power is turned off then proceed with filling the pump end with water. Note, the pump must be fully primed before starting.

Next close the valve on the outlet or discharge side of pump. Turn on power to the pump, when full speed is reached gradually open the discharge valve until specified flow rate is achieved.



#### Caution

**Operating the pump dry (without liquid) may cause severe damage.**

### 3. Stopping

When stopping the pump, first close the discharge valve gradually. When it is completely closed, turn off the power switch so that the pump stops. Never stop the pump suddenly by quickly closing a valve (i.e., solenoid or hydraulic valves).



#### Caution

**Quick valve closure may cause water hammer that can cause severe damage to the pump.**

### 4. Temperature

The pump itself may not suffer a change in performance due to temperature fluctuation. However, the liquid may change in terms of viscosity, vapor pressure, and corrosive properties. Pay special attention to changes in liquid characteristics as a result of temperature fluctuation.

Liquid temperature range: 32 – 176°F (0 – 80°C)

Ambient temperature range: 32 – 104°F (0 – 40°C)

### 5. As there is a powerful magnet inside the pump unit, do not use any liquid that contains metallic substances such as iron, nickel, etc.

### 6. Do not operate the pump in the following places:

- Places exposed to rain and/or wind.
- Places where the temperature falls below 32°F (0°C).
- Places where corrosive gas (such as chlorine) is present.
- Places exposed to splashing of water or fluid being pumped.
- Places where the ambient temperature is 104°F (40°C) or above.
- Places where explosive or combustible materials/gases are present.

7. Do not operate the pump with the following liquids:
  - For the compatibility to chemical liquid or any special liquid, contact an Iwaki America sales representative.
  - Liquids that significantly swell polypropylene.
  - Paraffinic hydrocarbons such as gasoline and kerosene.
  - Halogenated hydrocarbons such as trichloroethylene and carbon tetrachloride.
  - Ether and low-grade ester
  - Slurry  
(For a chemical compatibility, guide contact Iwaki America customer service.)
8. To prevent fire and explosions, do not place dangerous or flammable substances near the pump.
9. Be sure unit is properly grounded.
10. If a pump is damaged, it can be dangerous to operate. Contact factory for assistance.
11. Avoid direct physical contact with the motor or pump during operation, as surface temperatures may be extremely high due to operating conditions.

## **7 INSTALLATION, WIRING AND CONNECTIONS**

---

### **7.1 Installation**

1. **Installation site**

Installation site must have an ambient temperature of 32-104°F (0-40°C) and a relative humidity lower than 90%. Install the pump where maintenance and inspection work can be done easily.
2. **Pump installation method**

This pump is not self-priming. It is recommended that the pump shall be installed in a position lower than the liquid level of the suction tank by at least 12 inches (30 cm). If this distance is too short, air may enter the pump, causing damage.
3. **Direction of pump discharge port**

The discharge port can be directed as desired. However, for efficient elimination of air in the pump end, it is recommended that the discharge port be positioned in the horizontal direction.
4. **Anchoring of base**

The base of the pump must be anchored firmly. The pump must not be mounted in a vertical position.

## 7.2 Piping instructions

1. To minimize frictional resistance, the shortest piping possible with a minimum number of bends should be utilized on the inlet or suction side of the pump.
2. Use a corrosion-resistant vinyl hose that is rated at or above the pressure rating of the pump (see specification table).
3. Hose size (for hose-barb style pumps)  
Select hose size in accordance with the diameter of the pump connections. As the hose tends to be crushed under the force, the use of a braided reinforced hose is recommended. Note, if the connection on the suction side is loose air may be mixed in with pumped fluid.

**(In the case of high temperature liquids, special attention must be paid to the selection of a hose.)**

4. Hose connection  
Be sure to cut the ends of the hose straight. Press the hose end firmly against the discharge or suction port until it reaches the bottom of the port. Use a fastener (such as a hose clamp) to make the connection tight and leak free.



### **Caution**

**Do not over tighten the connection ports (suction and discharge) excessively as they are made of plastic resin and are could be damaged.**

5. Valve installation  
Install valves close to the suction and discharge ports.
  - Suction side valve:  
For easy liquid removal and pump maintenance
  - Discharge side valve:  
For adjustment of the discharge rate or head and for easy removal and pump maintenance.

## 7.3 Wiring

1. Prior to wiring the pump, confirm the voltage indicated on the nameplate is correct for your installation. (Observe all local and national regulations regarding electrical work.) The connection diagram is presented on the next page.
2. The pump does not have an external switch. It starts when power is supplied to the pump wires.

## Wiring diagrams

- (W)MD-15R, 20R, 20RX, 20RZ, 30R, 30RX and 30RZ (Single-phase capacitor run motor with thermal protector)

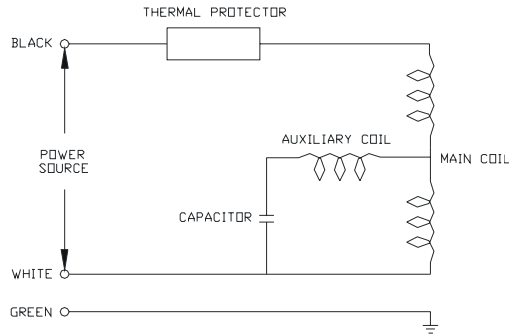

- (W)MD-40R, 40RX, 40RZ, 55R, 70R, 70RZ, and 100R (Single-phase capacitor run motor with thermal protector)

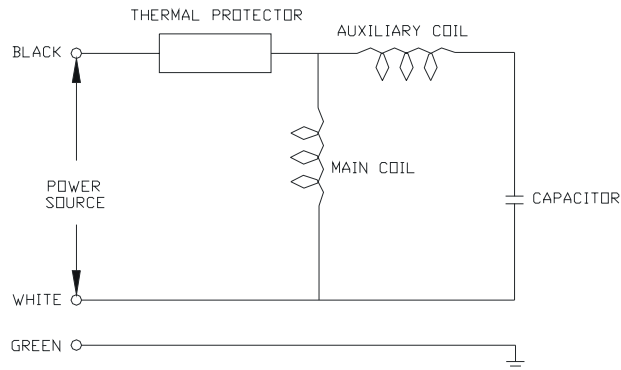

- MD-70R, 70RZ, and 100R models (3-phase motor, 220/380V)

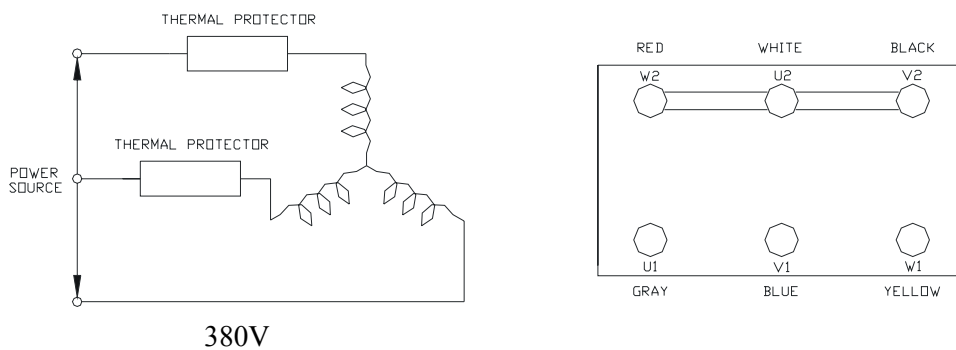
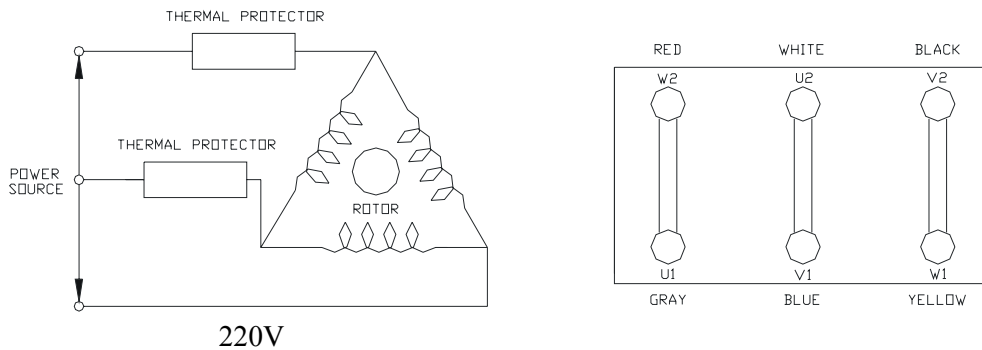

- (W)MD-70R, 70RZ, and 100R models (3-phase motor,400/440V)

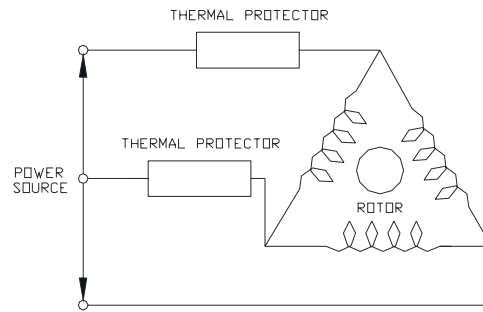

## 8 ASSEMBLY

---

1. Place the motor on end vertically so that the shaft is pointed upward.
2. Install the drive magnet on the motor shaft and position the shaft flush with the inside of the magnet. Note: On WMD models, screw the bracket to the motor first.
3. Insert the rear casing into the magnet/motor bracket.
4. Install the impeller and O-ring into the rear casing.
5. Place the front casing over the pump, making sure that the volute casing is aligned.
6. Using a hex head driver, fasten the liquid end to the bracket using six screws. Tighten in a star pattern.

## 9 OPERATION



### Caution

- Before operating the pump, confirm that connections to the discharge and suction ports are secure.
- Dry run operation (operation without liquid in the pump) damages the pump. Be sure to fill the pump with liquid prior to startup.
- Do not operate the pump with closed, or almost entirely closed, suction and/or discharge side valve(s). A closed suction valve will cause dry-run operation.
- Do not open or close the suction or discharge side valve suddenly, this may result in decoupling and damage to the pump end. (Under such circumstances, turn off the power supply immediately. When the motor stops rotating, the magnetic coupling will be reconnect automatically.)

No.	Operation Step	Note
1	Check piping, wiring and voltage.	Check connections to confirm they are secure and leak-free. Check the power supply voltage by referring to the information on the nameplate.
2	Open and close valves.	Fully open suction side valve. Fully close discharge side valve.
3	Check that pump chamber is filled with liquid.	Fill pump chamber with priming liquid. Be sure suction line is completely filled, this is especially important if pump is above liquid level.
4	Supply power to pump	After steps 1 to 3 above, connect power supply to start pump.
5	Adjust discharge capacity & head to desired values.	Adjust discharge side valve gradually till desired discharge capacity and head are obtained. Do not open or close valves suddenly. <b>Note: Do not keep discharge side valve closed for more than 1 minute.</b> <b>Note: Check that pump is operating normally. If not, turn off power immediately and eliminate cause referring to 'Causes of Trouble and Troubleshooting' section (p.27).</b>
6	Checkpoints during operation	Be careful to prevent solids from entering the pump. Solids in the pump may cause impeller to be locked stopping liquid circulation. The motor continues to rotate even if impeller is locked. In such a case, turn off power supply at once.

## Pump Stopping Procedure

No.	Stopping Step	Description
1	Close discharge side valve.	Close discharge side valve gradually. Do not use electromagnetic valve for quick closing.
2	Switch power off.	Check that motor stops smoothly after power supply is disconnected. If not, pump should be inspected. (For details, contact Iwaki or your dealer.)

### How to store pump when it is out of use for a long time

Remove the liquid from the pump if it is to be stored for a long period of time. In addition, run it with water for about 5 minutes every 3 months to prevent rust on the motor bearing.

#### Warning

- Before draining the pump, turn off the power supply.
- Be sure to wear proper safety gear (gloves, protective shoes, etc.) when handling pump end for draining purposes, especially when a hazardous chemical is being pumped.



#### Caution

Note that residual liquid may run from the discharge and suction ports when the housing is removed. Do not allow any electric parts to come in contact with the liquid.

Never discharge hazardous or chemical liquid over the ground or floor in the plant. Instead, use a draining pan (or container). Observe each applicable local law or regulation for the handling or disposal of hazardous liquids.

### Draining procedure

1. Turn off the power supply. (Make sure no other operator will turn the power supply on accidentally.)
2. Close the discharge and suction sides valves fully.
3. Remove the hoses piping attached to the pump.
4. Remove the screws on the pump base to detach the pump from its mounting location.
5. Rotate the pump.
6. Discharge hazardous liquids appropriately.

## 10 MAINTENANCE/INSPECTION

### Maintenance and inspection

- When the pump has been used for a long time, the front casing screws attaching the pump head to the motor bracket may loosen. Tighten screws periodically taking care not to deform the plastic parts. Also, after pump has been stored for a long time, tighten screws before pump is used again.
- Daily inspection  
Check operating conditions (vibration, noise) as well as electric current value and pump discharge capacity. As soon as you find any abnormality, turn off power and refer to “Troubleshooting” on page 27.

## 11 PARTS DESCRIPTION AND EXPLODED VIEW

### TYPICAL MD-6 through 40

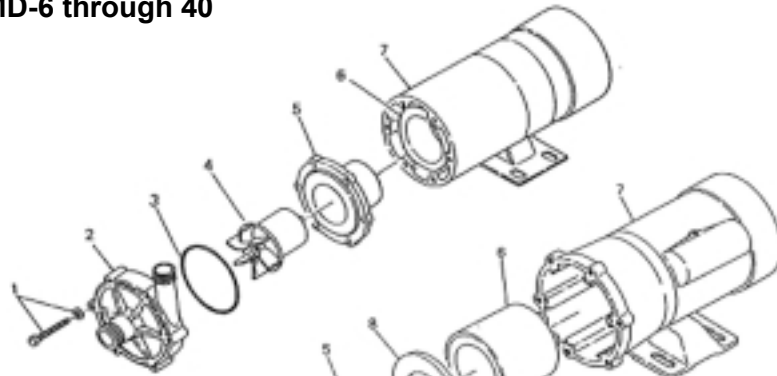

### TYPICAL MD-55/70/100



### TYPICAL WMD

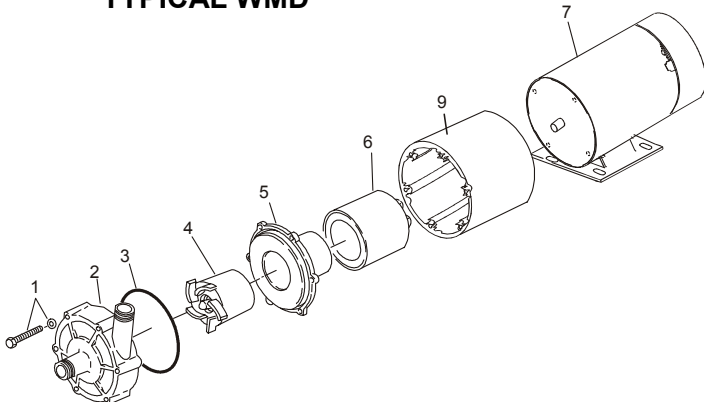

Item No.	Description	Item No.	Description
1	Screw	5	Rear Casing
2	Front Casing	6	Drive Magnet
3	O-Ring	7	Motor Assembly
4	Impeller	8	Retainer (MD-100R,100F,55F only)
		9	Bracket

## 12 DIMENSIONS

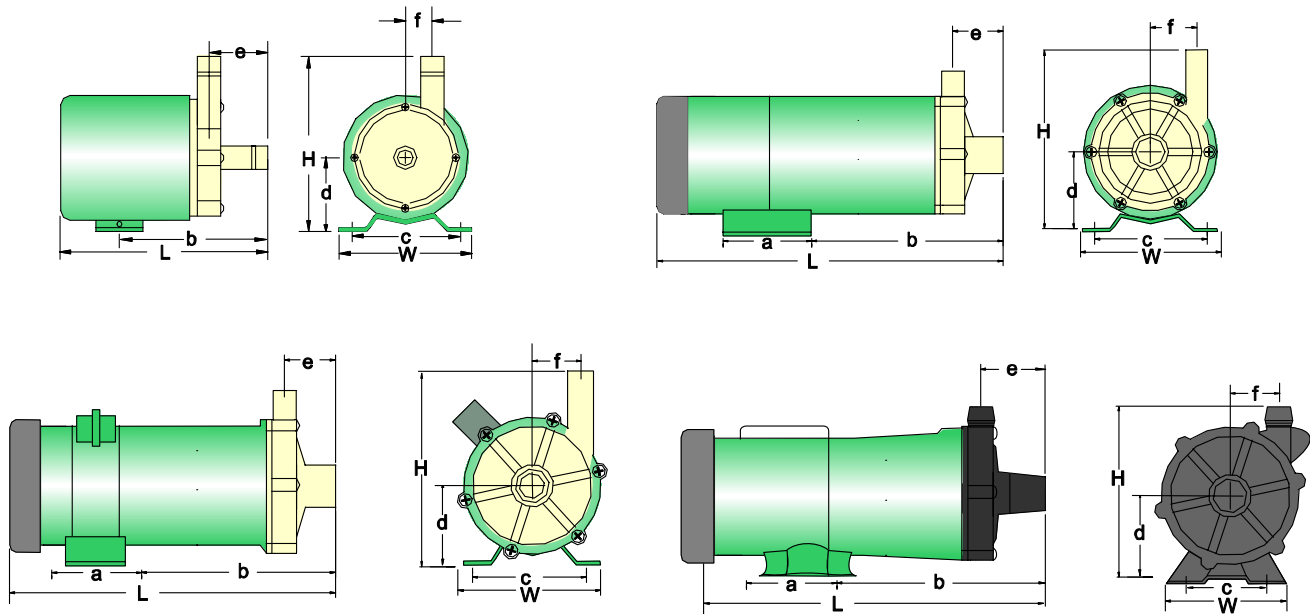

Dimensions in inches

Model	Connections		W	H	L	a	b	c	d	e	f
	Hose	NPT(M)									
<b>Polypropylene Models (MD-115V models only)</b>											
MD-6/10	1/2	---	2.91	3.62	4.09	---	2.87	2.36	1.77	1.22	0.67
WMD-15R(T)	1/2	1/2	3.50	4.26	9.46	2.37	4.15	2.50	1.94	1.52	0.85
MD-15R(T)	1/2	1/2	3.74	4.39	7.05	---	4.59	3.35	2.17	1.52	0.85
WMD-20R(T)	5/8	3/4	3.50	4.35	9.70	2.37	4.39	2.50	1.94	1.30	1.12
MD-20R(T)	5/8	3/4	4.17	4.19	7.99	1.73	4.06	3.54	1.77	1.30	1.12
WMD-20RX(T)	1	1	3.50	4.95	10.37	2.37	5.06	2.50	1.94	1.83	40+
MD-20RX	1	1	4.17	4.75	8.66	1.73	4.45	3.54	1.74	1.83	40+
WMD-20RZ	5/8	3/4	3.50	4.70	9.98	2.37	4.67	2.50	1.94	1.56	1.52
MD-20RZ	5/8	3/4	4.17	4.92	8.31	1.73	4.17	3.54	2.17	1.56	1.52
WMD-30R	3/4	3/4	3.50	4.70	11.65	2.37	5.72	2.50	1.94	1.89	1.22
MD-30R	3/4	3/4	4.72	5.12	9.76	1.57	5.87	3.94	2.36	1.89	1.22
WMD-30RX	1	1	3.50	5.09	11.89	2.37	5.96	2.50	1.94	1.97	40+
MD-30RX	1	1	4.72	5.51	10.00	1.57	6.10	3.94	2.36	1.97	40+
WMD-30RZ	5/8	3/4	3.50	4.70	10.97	2.37	5.04	2.50	1.94	1.56	1.53
MD-30RZ	5/8	3/4	4.72	5.12	9.05	1.57	5.16	3.94	2.36	1.56	1.53
WMD-40R	3/4	3/4	4.38	4.84	11.34	3.09	6.66	3.37	2.08	1.89	1.22
MD-40R	3/4	3/4	4.72	5.12	9.85	1.57	5.87	3.94	2.36	1.89	1.22
WMD-40RX	1	1	4.38	5.23	11.30	3.09	7.02	3.37	2.08	1.97	43+
MD-40RX	1	1	4.72	5.51	10.08	1.57	6.10	3.94	2.36	1.97	43+
MD-55R	1	1	4.72	6.10	10.77	1.57	7.05	3.94	2.56	2.42	1.57
MD-70R	1	1	5.63	6.11	10.18	2.76	5.71	4.25	2.56	2.07	1.70
MD-70RZ	3/4	3/4	5.63	6.50	9.72	2.76	5.24	4.25	2.56	1.65	1.87
MD-100R	1	1	6.14	6.89	12.67	2.76	6.38	4.33	2.95	2.55	1.71
WMD-100R	1	1	6.14	7.44	*	3.00	10.43	4.87	3.50	2.55	1.71
<b>Fluoroplastic Models (MD-115V models only)</b>											
WMD-30F (X,Y,Z)	---	1/2	3.50	5.02	11.82	2.37	6.67	2.62	2.29	1.84	1.22
MD-30F (X,Y,Z)	---	1/2	4.72	5.12	9.09	1.57	6.77	3.94	2.36	1.53	1.52
MD-55F (Y,Z)	---	1/2	4.72	6.11	10.53	1.57	6.61	3.94	2.56	2.30	1.56
WMD-100F (Y,Z)	---	1	6.60	6.80	*	3.00	12.05	4.88	3.56	2.55	1.71
MD-100 (Y,Z)	---	1	6.14	6.89	12.67	2.76	6.38	4.33	2.95	2.55	1.71

## 13 TROUBLESHOOTING

	Pump does not start.	Pump is not pumping or flow is insufficient.	Electric current is high.	Excessive noise or vibration.	Liquid leaks.	
Power is not supplied or wiring is faulty.	○		○			Check power connections or contact your dealer.
Motor is out of order (short coil or capacitor failure).	○		○			Contact your dealer.
There is residual air in the pump.		○		○		Eliminate air from pump end completely.
Air is sucked in via suction port.		○		○		Check suction connection.
Pump is running dry.		○		○		Supply priming water to pump.
Specific gravity/viscosity of liquid is too high.	○	○	○			Confirm application with pump specifications.
Periphery of impeller magnet is in contact with rear casing.	○	○	○	○		Contact your dealer.
Impeller is damaged.	○	○	○	○		Contact your dealer.
Foreign matter is stuck to impeller.		○	○	○		Contact your dealer.
O-ring is damaged.					○	Contact your dealer.
Loose front casing bolts.		○			○	Tighten bolts.



5 BOYNTON ROAD HOPPING BROOK PARK HOLLISTON, MA 01746 USA  
 TEL: 508-429-1440 FAX: 508-429-1386 www.iwakiwalchem.com