

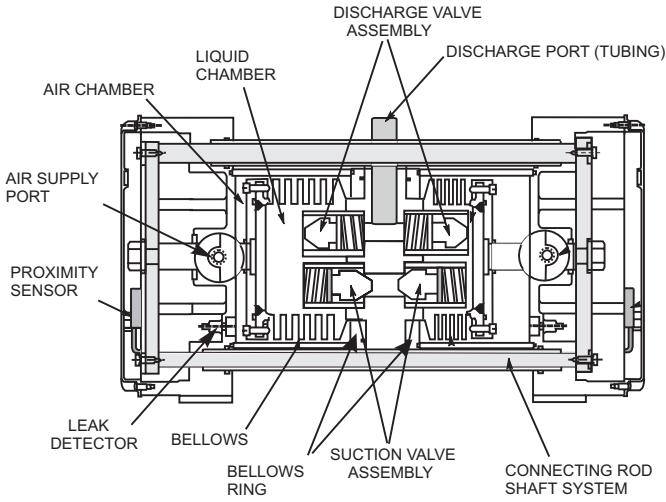

IWAKI WALCHEM Corporation

# FW-80T



- PTFE/PFA Liquid End Construction
- Pressure capabilities to 75 PSI
- Flow rates to 86 L/min
- Temperature capability of 100°C
- Leak detection and drive sensing

## Dimensions

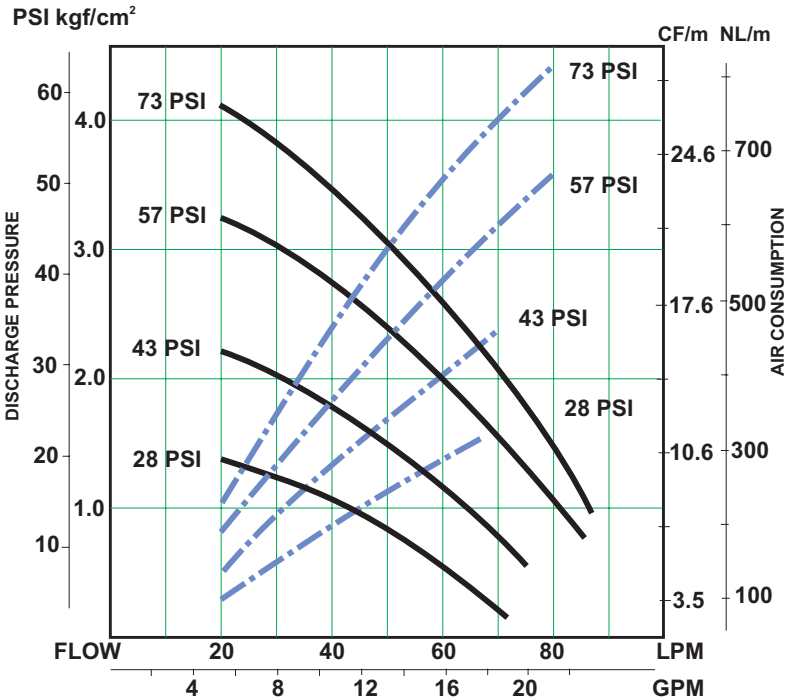
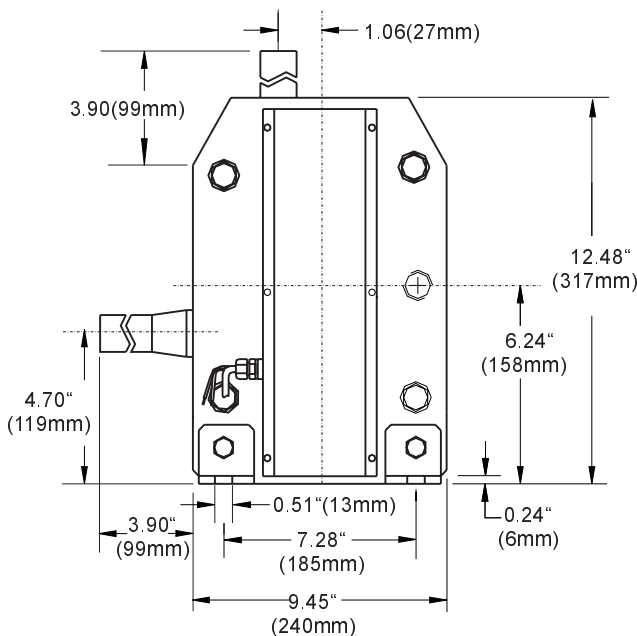
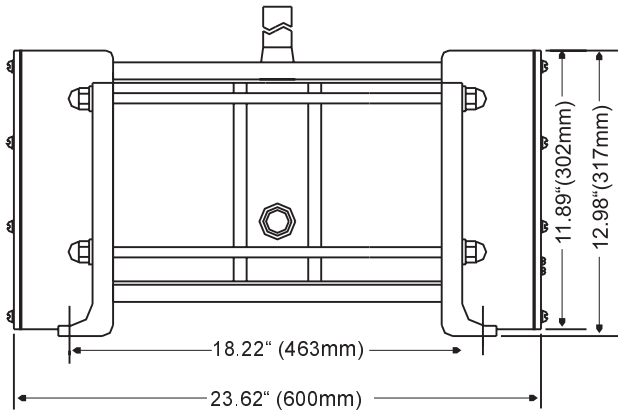

— PUMP PERFORMANCE CURVE — AIR SUPPLY PRESSURE  
NOTE: RATED PERFORMANCE AT CORRESPONDING SUPPLY AIR PRESSURE.

## Specifications

FW-80T		
Max flow rate	GPM (LPM)	22.7 (86)
Liquid Temperature	°F (°C)	50-212 (10-100)
Supply air pressure	PSI	29-73
Ambient temperature	°F (°C)	32-104 (0-40)
Max stroke speed	SPM	80
Pump connection size		1" PFA tube
Supply air connection size		1/2" PT (2)
Material	Wetted parts	PTFE, PFA
	Non-wetted parts	PTFE COATED ALUMINUM, SS304

P/N IF20353.B