



***IWAKI WALCHEM
PUMP CONTROLLER
MODEL FD-2
INSTRUCTION MANUAL***



IWAKI WALCHEM Corporation

Thank you for purchasing the Iwaki Walchem Pump Controller model FD-2. This controller has been designed especially for Iwaki Walchem's pneumatic-driven bellows pump series FW, FW-H, FF, FA, FH and FZ. Please read this instruction manual as well as the instruction manual of your pump before and during the use of FD-2 Pump Controller.

Table of Contents

1	Unpacking and Inspection.....	2
2	Specifications	2
	Controller Specifications	2
	Solenoid valve: 4 way, Externally piloted.....	3
	Electromagnetic Regulator Model EV2500.....	4
	Dimensions – Electropneumatic Regulator.....	5
	Dimensions – FD-2 Pump Driver.....	6
3	Names and Descriptions of Parts.....	7
4	Features	8
5	Installation.....	9
	Installation of panel mount driver.....	9
6	Electrical Wiring	9
7	Air Piping	13
	Installation Tips	13
	Installation of the Electropneumatic Regulator.....	13
	Installation of the Automatic Pulsation Dampener.....	13
8	Description of Functions	14
	Pump operation (see Figure 9).....	14
	Fixed stroke rate mode (see Figure 9)	15
	Leak alarm.....	15
	Time-up alarm (see Figure 10)	15
9	Operation.....	16
	Preparation.....	16
	Starting Pump Operation	18
10	Troubleshooting	19

1 Unpacking and Inspection

Open the package and check that the product conforms to your order. For any problem or inconsistency, contact Iwaki Walchem or your distributor at once.

1. Check that the model number indicated on the nameplate conforms to the specifications of your order.
2. Check that all the accessories you ordered are included.
3. Check that the controller and parts have not been accidentally damaged or that any bolts or nuts have not been loosened in transit.

2 Specifications

Controller Specifications

General Specifications	Power supply		DC24V \pm 10%
	Power consumption		12 VA
	Ambient temperature		0 - 55°C
	Ambient humidity		5 - 95% RH (non-condensing)
Input Specifications	Proximity sensor A & B	Input resistance	4.7k Ω (pull-up to 24V) Negative logic action
		Input voltage	"L" = 0-3V, "H" = 5-30V
		Sensor power	DC24V, 20 mA
	Electrode (leak detection)	Inter-electrode voltage	DC 5V \pm 5%
		Operating resistance	Resistance of 0-15k Ω is detected, but higher than 25k Ω is not.
	Timer dial	Setting range	0-30 sec. \pm : 10% of full scale 30-60 sec. \pm :15% of full scale
	External start signal	AUTO operation	Relay contact
	External stroke rate variable selection signal	Input resistance	0-100% variable by 0-5k Ω input
		AUTO operation	Relay contact Contact on: Variation by external signal Contact off: Variation by panel volume
	Pump max. stroke rate	4-step selection with dip set selection switch in PCB (for 80, 120,150 & 200 spm)	

Output Specifications	4 Way, 24VDC Solenoid Control Valve	Output type	NPN open collector
		Output load voltage	DC24V \pm 10% load current, 0.75A max.
		Withstanding voltage	35V
		Residual voltage	1.5V or below
	Leak alarm output	Output type	Relay contact output DC30V 5A
	Time-up alarm output	Output type	Relay contact output DC30V 5A
	Electropneumatic regulator control signal output	Output signal	Analog signal DC 0-10V, 50 mA
		Resolution	8-bit D/A converter
External stroke number variation output voltage	Output voltage	DC4V	
Control Specifications	Types of pumps to be controlled	All F Series pneumatic driven bellows pumps: FA, FF, FF-H, FH, FW, FW-H & FZ series	
	Range of set speed	10 -90% of specified max. stroke (depending on operating conditions of each pump)	

Solenoid valve: 4 way, Externally piloted (P/N SMC NVFS3120R-5DZ-03T)

Valve	Fluid	Air and inert gas
	External pilot Max. operating pressure	150 PSI (9.9kgf/cm ²)
	External pilot Min. operating pressure	15 PSI (1.0 kgf/cm ²)
	Ambient & fluid temperature	14 to140°F (-10 to +60°C) ^{Note 1}
	Lubrication	Not required ^{Note 2}
	Pilot operator manual override	Non-locking push type (flush), std.
	Protection construction	Dust proof
Electrical	Rated voltage	24 VDC
	Allowable voltage range	-15 to +10% rated voltage
	Coil insulation	Class B or equivalent
	Power consumption DC	1.8W
	Electrical entry	DIN connector

Notes:

1. Use dry air at low temperature.
2. Use turbine oil No. 1 (ISO VG32), if lubricated.

Electromagnetic Regulator Model EV2500

Media	Clean dry air (CDA)	
Max. working pressure	100 PSI (7.1 kg/cm ²)	
Min. working pressure	Control pressure + max. control pressure x 0.1	
Guaranteed pressure proof	Inlet side	150 PSI (10.7 kgf/cm ²)
	Outlet side	110 PSI (7.6 kgf/cm ²)
Pressure control range	0-70 PSI (0-5.0 kgf/cm ²)	
Power supply voltage	24VDC ±10% (stabilized power supply with a ripple rate of 1% or less)	
Consumption current	0.1A or less (rush current: 0.6A when the power is turned on)	
Input signal (Input impedance)	0-10VDC (10kΩ), 0-5VDC (20kΩ), 4-20 mA DC (250Ω)	
	10kΩ variable resistor	
Hysteresis	1% F.S. or less ^{Note 1}	
Linearity	±0.5% F.S. or less	
Resolution	0.5% F.S. or less	
Repeatability	0.5% F.S. or less	
Max. flow rate (ANR)	800 l/min	

Notes:

1. This specification applies to power supply voltage at 24VDC.

Dimensions – Electropneumatic Regulator

TOP VIEW

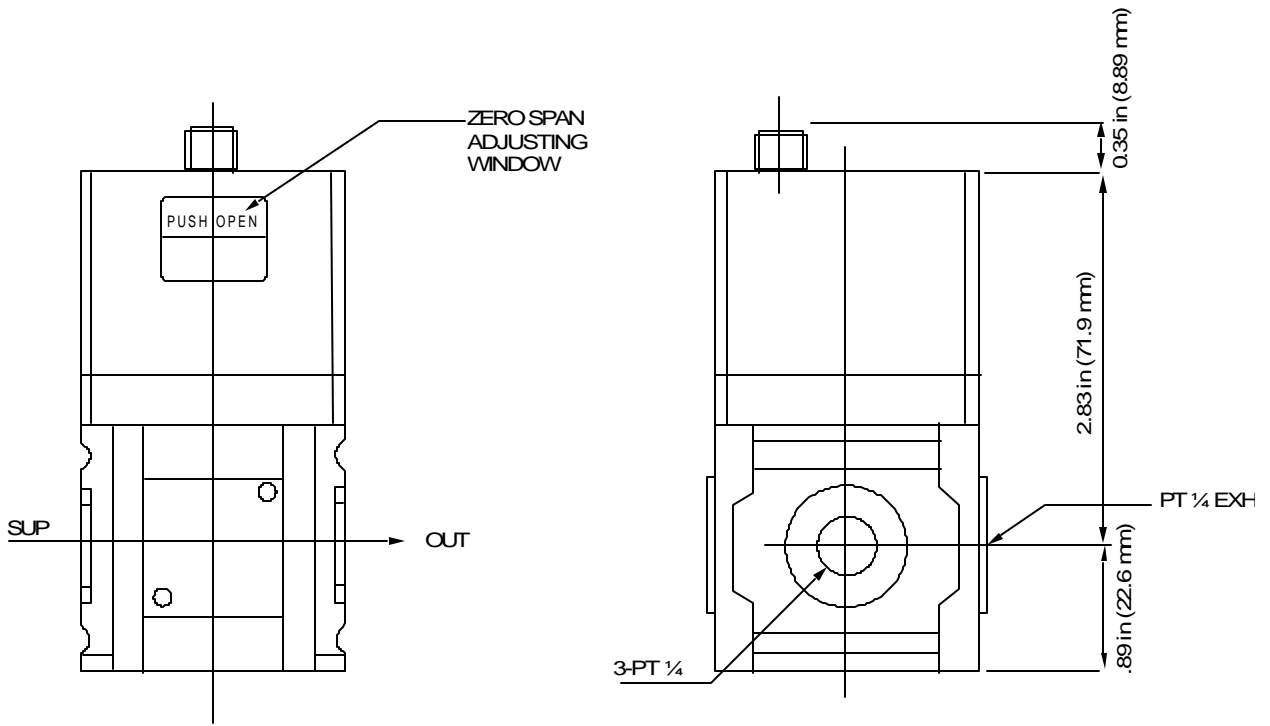
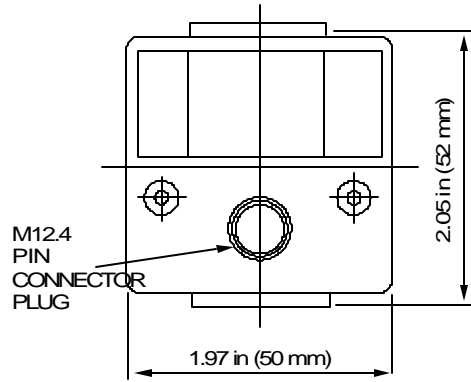

SIDE VIEW

Figure 1

Dimensions – FD-2 Pump Driver

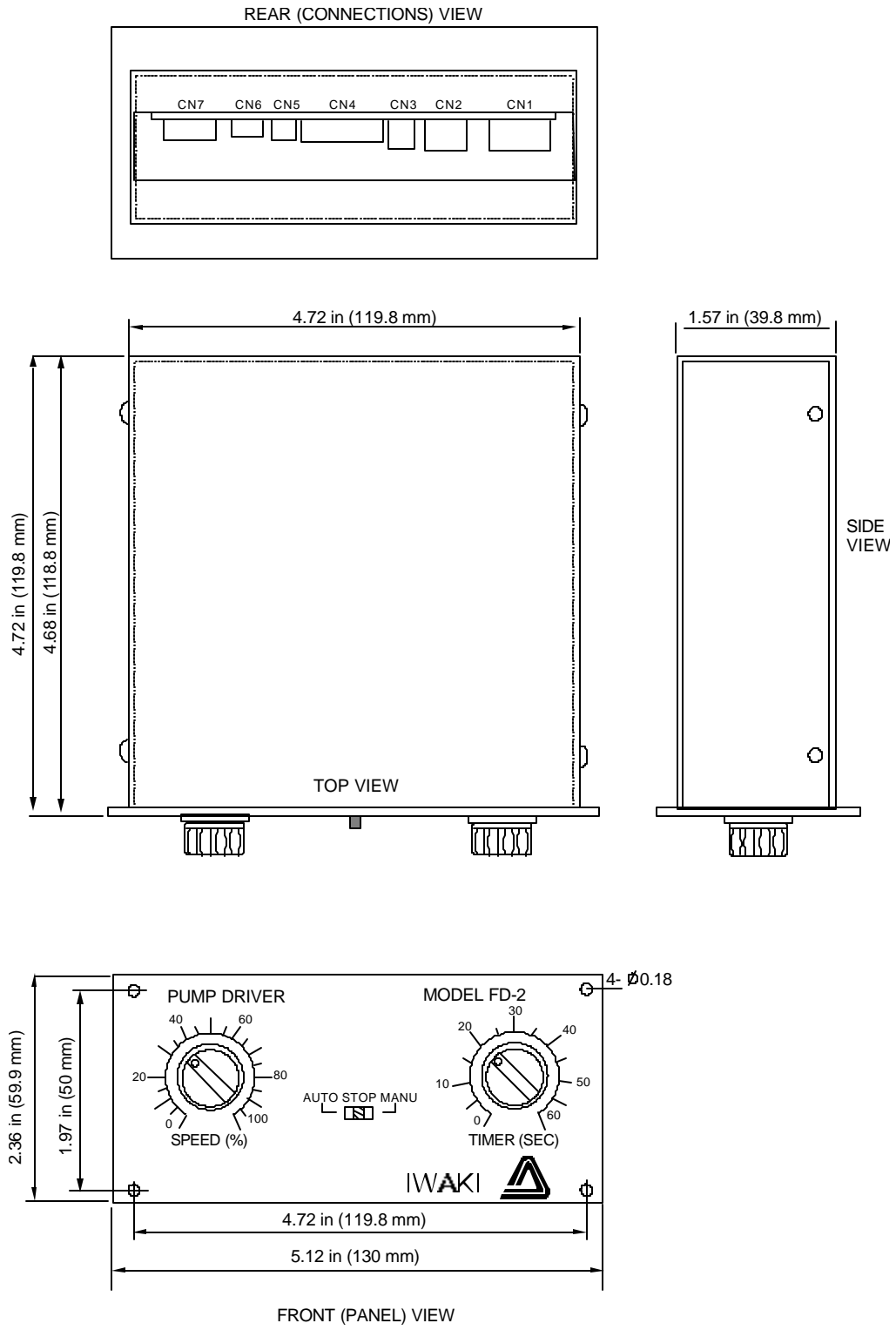

Figure 2

3 Names and Descriptions of Parts

- 1 Start switch
- 2 Speed control dial (%)
- 3 Timer control dial (sec.)
- 4 Alarm output connector
- 5 Solenoid valve output connector
- 6 Power supply input connector
- 7 Input connector for leak sensors and pump proximity sensors
- 8 Input connector for external start signal
- 9 Output connector for electropneumatic regulator power and control
- 10 Input connector for external stroke rate control

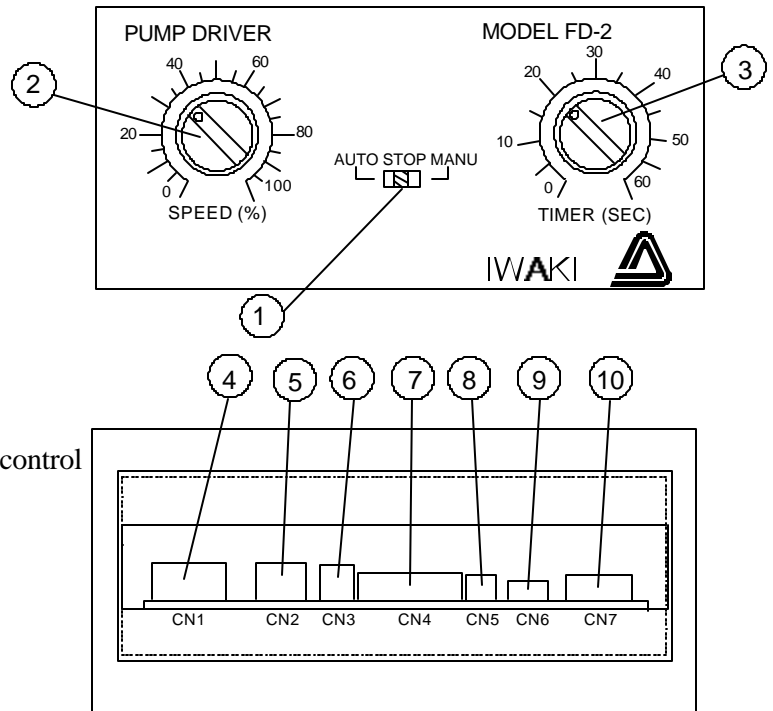

Figure 3

1. Start switch

MANU: Sliding this switch to the MANU position starts pump operation (in the manual mode).

STOP: Sliding this switch to the STOP position stops pump operation completely.

AUTO: When the switch is set to AUTO and the external contact signal is turned ON, the pump starts operation. With the external contact signal OFF, the pump stops operation (in the AUTO mode).

2. Speed control dial

This dial is used to set the pump stroke as a percentage of maximum specified stroke rate. If the maximum specified stroke rate is 120 strokes per minute (spm), setting this dial to 50% results in a pump speed of 60 spm. (depending upon the pump load conditions).

Note: Actual stroke rate is dependent upon the pump discharge backpressure conditions which may vary. Pump stroke rate should be adjusted during start-up to achieve desired flowrate.

3. Timer control dial

This dial is used to set the lower time limit of the pump speed. If the time required for the bellows to complete a single stroke exceeds the preset time (seconds), the FD-2 controller then activates the timer alarm signaling a pump slowdown or stall.

4. Alarm output connector
The leak alarm and timer alarm output signals are connected with this connector.
5. Solenoid valve output connector
The electropneumatic valve is controlled by cycling power on and off from the controller.
6. Power supply input connector
DC24V+ 10% is required for operation of the controller.
7. Input connector for leak sensors and pump proximity sensors
The leak sensors and pump proximity sensors are used for feedback and positive control of the pump.
8. Input connector for external start signal
In the AUTO mode, the pump can be started by an external contact signal.
9. Output connector for electropneumatic regulator power and control
The electropneumatic regulator is supplied with power from the controller as well as a 0 – 10 VDC control signal.
10. Input connector for external stroke rate control
The stroke rate can be adjusted from an external signal similar to the speed control dial on the front of the controller.

4 Features

1. Pump stroke rate is fully adjustable from 10-90% of maximum pump rating. Regardless of the load on the pump discharge side, the preset stroke rate will be maintained automatically.
2. In AUTO mode, an external contact signal starts or stops the pump.
3. The flow rate of the pump may be varied via an external control signal.
4. If either of the bellows rupture, the leak alarm signal will activate and the pump will stop immediately.
5. Using the Speed Control Dial, the standard time required for a single pump stroke can be set. In addition, slow or stalled pumping can be detected by the timer alarm output feature.
6. The air pressure supply to the pump is controlled by the electropneumatic regulator, keeping the differential pressure across the bellows to a minimum. This significantly extends the service life of the bellows.
7. By utilizing the control features of the FD-2 controller, quality issues such as flow rate, pump life, filter life, etc., are optimized.

5 Installation

Panel Mount Installation

1. Make a cutout in the panel for the controller (1.61in. x 4.92 in.).
2. Drill holes for the installation screws (1.97in. x 4.72in.). 3/16" diameter recommended.
3. Insert the controller unit through the panel cutout and secure with appropriate hardware.
4. The depth dimension requirement is 5.50 in. minimum (including tolerances).

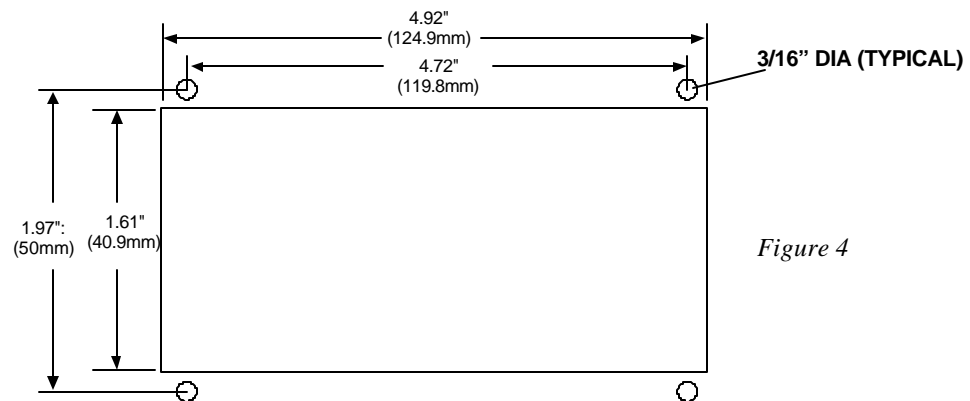

6 Electrical Wiring

Figure 7 shows the basic wiring diagram of the pump controller. Refer to the diagram and follow the procedures described below to properly wire the unit. Note that faulty wiring may result in failure or malfunctioning of the controller or pump.

Connecting the DC24V power supply to the FD-2 controller

- Required: DC 24V power supply (minimum capacity of 0.5A).
- Connect 1P and 2P of CN3 to the "+" and "-" terminals of the power supply respectively.

Connecting the FD- 2 controller to the pump

- Only the proximity sensor & leak sensor wires should be connected between the FD- 2 and pump.



CAUTION Do not use the leak sensors with flammable liquids!

- Connect proximity sensor L to 3P, 4P and 5P of CN4. (The air line from the normally open side of solenoid valve should be connected to the L side of the pump.)
- Connect proximity sensor R to 6P, 7P and 8P of CN4. (If the air line from the normally open side is connected to the R side of the pump, reverse the wiring of proximity sensors L and R.)
- C1, C2, D1 and D2 in Figure 7 are the electrodes within the pump unit. Connect the electrode lead in series with 1P and 2P of CN4, as shown in the diagram.
(If the C1 and C2 electrodes or D1 and D2 electrodes are shorted by an electrolytic fluid whose resistance is 0-15k Ω , the leak alarm will be activated)

Connecting the FD- 2 to the Solenoid Valve (4 way, Externally Piloted)

- Connect the "+" and "-" terminals of the solenoid valve to 3P and 1P of CN2 respectively.
- Use 4 conductor shielded cable, 22-24 gauge, for wiring.

Connecting the FD-2 to the Electropneumatic Regulator, EV2500

- To connect the EV2500, use Omron's model XS2C-D422 connector (supplied with regulator).
- Connect the EV2500 to the FD-2 as follows:

EV2500-008		XS2C-D422	CN6	
1P	DC24V power	1P	1P	DC24V power
2P	Monitor output	2P	--	No connection
3P	Common	3P	3P	GND
4P	Control	4P	2P	DC 0-10V output

- The shielded wire should be connected with the GND in CN6.

Connecting the FD- 2 to a host controller

Alarm output wiring

- 1P and 2P of CN1 are for the leak alarm output.
- 3P and 4P of CN1 are for the time-up alarm output.
- These alarms are contact closures only. They may require an external relay and power supply depending upon the type of alarm.

Wiring an external start signal from the host controller

- Closing a contact between 1P and 2P of CN5 starts the FD-2, thus the pump operation.
Opening the contact stops the FD-2 and pump operation.

Wiring external stroke rate control from the host controller

- A maximum resistance of $5k\Omega$ should be connected between 1P, 2P and 3P of CN7. Adjustment between 0 and $5k\Omega$ results in a speed change between the 0 and 100% levels (see Figure 5).
- If using an analog signal, the speed can be changed from 0 to 100% by inputting 0-4V to 2P and 3P (see Figure 6).
- In both cases, 4P and 5P must be shorted together from the host controller to allow the FD-2 to be controlled externally.

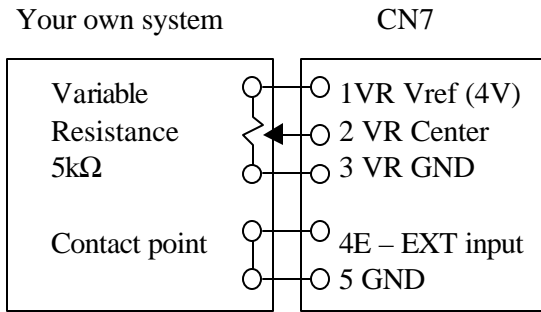

Figure 5

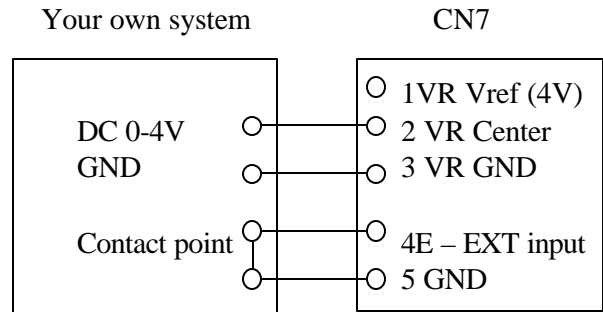

Figure 6

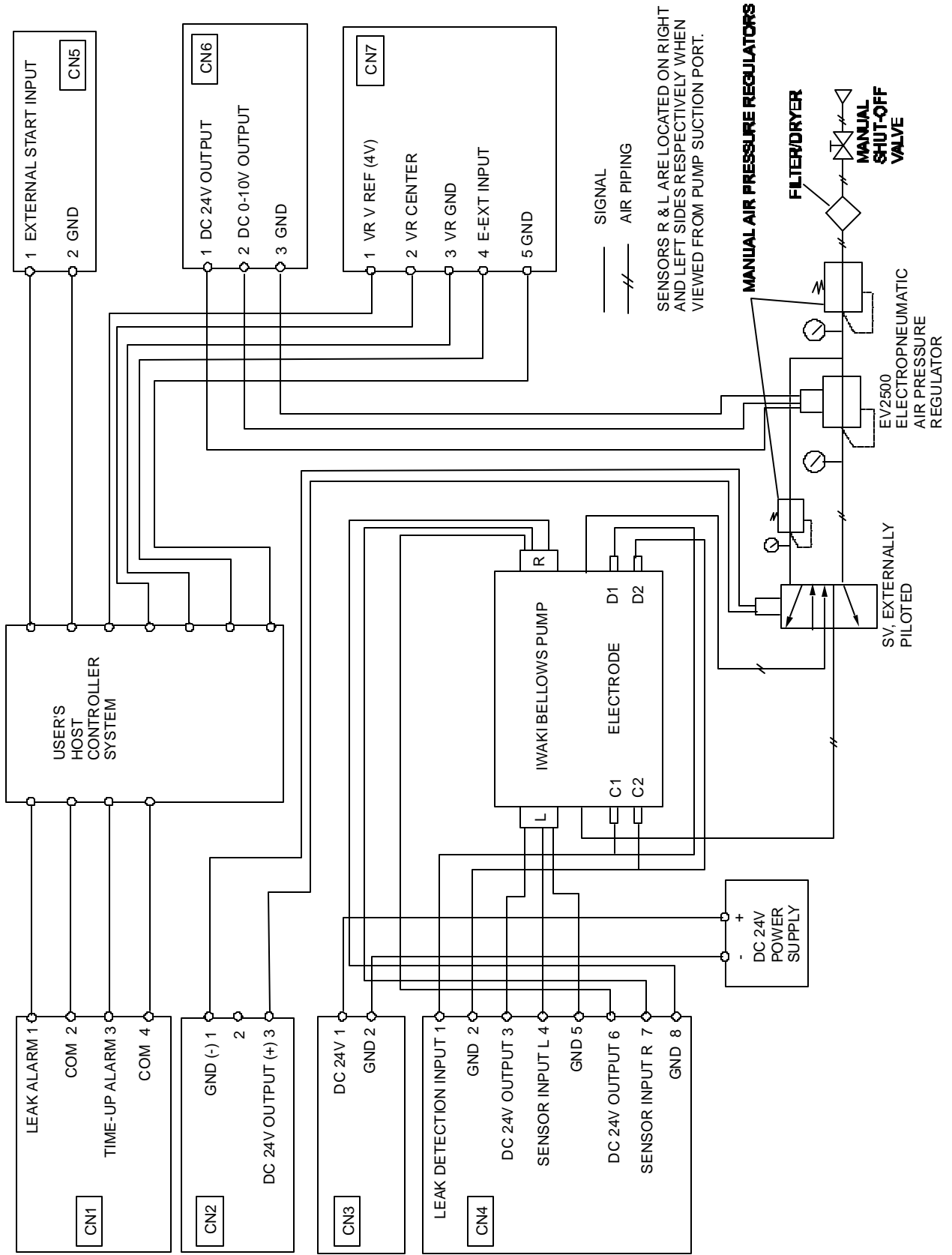

Figure 7 Basic Plumbing and Wiring

7 Air Piping

Refer to Figure 7 “Basic Wiring/Plumbing Diagram” while designing/installing the air line layout.

Installation Tips

1. Poor quality air supply hampers the operation and the durability of parts. Be sure to use a dryer, filter, or mist separator on the air supply source to completely remove any solids, water, grease, or oil.
2. Flush all air lines before plumbing together. Be careful not to leave any pipe tape inside the pipe as this can interfere with regulator operation.
3. A manual air pressure regulator is required on the air supply line **BEFORE** the electropneumatic regulator . This will stabilize the air pressure into the electropneumatic regulator ensuring consistent performance and control. More important, the manual air pressure regulator controls the upper pressure limit to which the pump or dampener could possibly be exposed.

FF-H, FH	35 [psi]	FF	50 [psi]
FA	65 [psi]	FZ	45 [psi]
FW-H	25 [psi] *	FW	75 [psi] *

* Maximum air pressure is dependent on fluid temperature (see pump specs).

4. Refer to the pump instruction manual for the proper line size of air supply piping or tubing. Full port air lines and accessories reduce excess pressure required which can increase pump life.

Installation of the Electropneumatic Regulator

Connect the manual regulator and the solenoid valve with pipe or suitable tubing of the appropriate size, length and material. For detailed instructions, refer to the instruction manual of the electropneumatic regulator.

Installation of the Automatic Pulsation Dampener

The air line coming out of the electropneumatic regulator, going into the solenoid valve, should be branched to the air inlet port of the dampener. (Figure 8). For detailed instructions, refer to the instruction manual of the Automatic Pulsation Dampener.

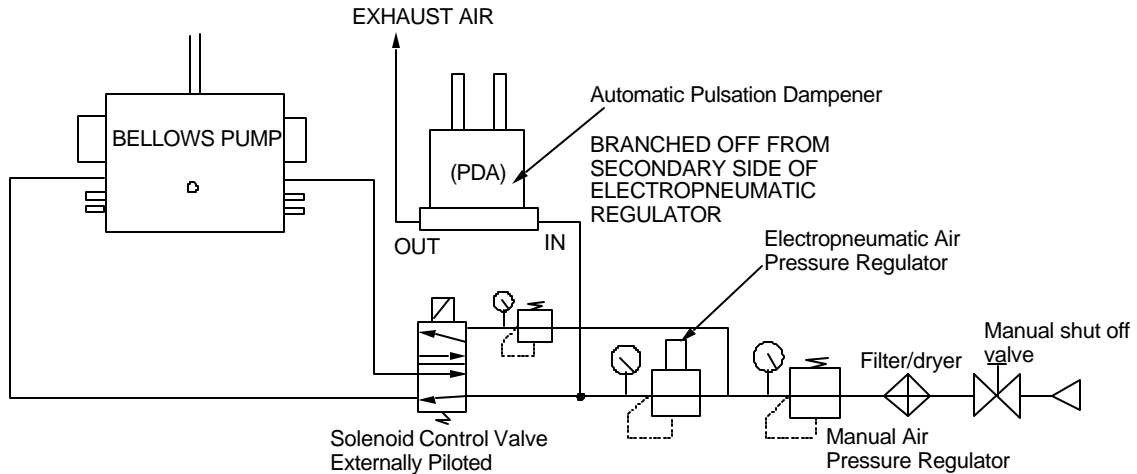

Figure 8

8 Description of Functions

Pump operation (see Figure 9)

1. Turn on air pressure to the pump. Turn on the controller (move switch to MAN or AUTO for external signal).
2. Air will fill the left chamber of the pump causing the bellows to move to the right side. When sensor R turns "ON", the solenoid valve output turns and remains in the "ON" condition. This changes the air direction from the solenoid valve causing air to fill the right chamber and move the bellows back to the left side of the pump. Sensor R turns "OFF" as the bellows moves from right to left, but the solenoid valve output remains in the "ON" condition.
3. As the bellows reach the left side of the pump, sensor L turns "ON" and the solenoid valve output enters the "OFF" condition. The air then switches sides again and the process repeats itself. The solenoid valve output remains in the "OFF" condition until the bellows moves to the right and sensor R once again turns "ON".

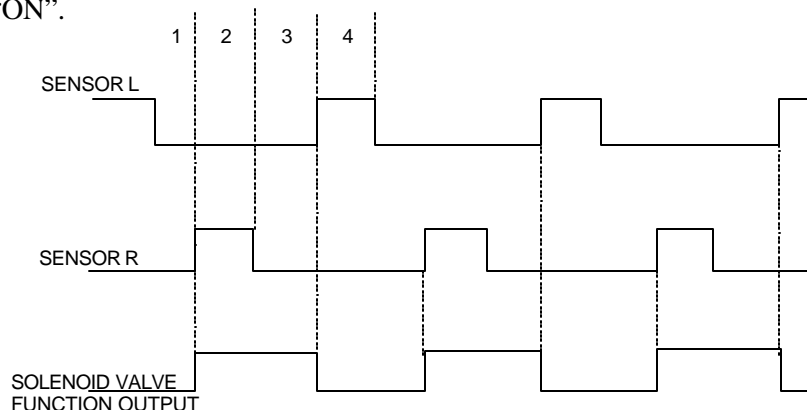

Figure 9

Fixed stroke rate mode (see Figure 9)

1. On start-up, the electropneumatic regulator output air pressure is 28 PSI (2.0 kgf/cm²). If no input is made by the proximity switch during the first 5 seconds after start-up, the air pressure increases to 35 PSI (2.5 kgf/cm²) and the timer alarm output is activated. Otherwise the pump will start running and either slow down or speed up depending on the speed setting and system parameters.
2. The output air pressure of the electropneumatic regulator can be adjusted by changing the dial on the front side of the FD-2 (MAN mode) or the external input signal (AUTO mode).
3. To determine a stroke rate setting, measure the current number of strokes per a unit of time (i.e. minute) and adjust accordingly. Repeat this process as necessary to obtain the exact stroke rate desired.

Leak alarm

1. The leak detectors operate by using a 5 VDC $\pm 5\%$ potential voltage. When a liquid or medium with a resistivity in the 0 - 15k Ω range makes contact with both electrodes, the circuit is closed.
2. When the circuit is closed, the signals to the solenoid valve and the electropneumatic regulator are turned OFF to suspend pump operation. The pump will release any residual pressure inside the air chambers.

Time-up alarm (see Figure 10)

1. The Time-up function is set by the dial on the face of the FD-2 controller.
2. The Time-up alarm will be activated whenever the "ON" time between proximity sensors L and R exceeds the preset time set on the dial. For example, if " t_0 " is the time set on the dial, the time-up alarm will be activated whenever the time between sensor actuations " t_i " becomes longer than " t_0 ". This is also the case during a pump stall or stop scenario because " t_i " becomes very large, exceeding " t_0 ".
3. The controller and pump will continue operation as normal during a time-up alarm. Unlike leak detection, the time-up alarm does not turn off signals to the solenoid valve or regulator.
4. As the pump speed begins to increase, the time between sensor actuations, " t_i " reduces. Once " t_i " becomes less than " t_0 ", the time-up alarm automatically resets and shuts off.

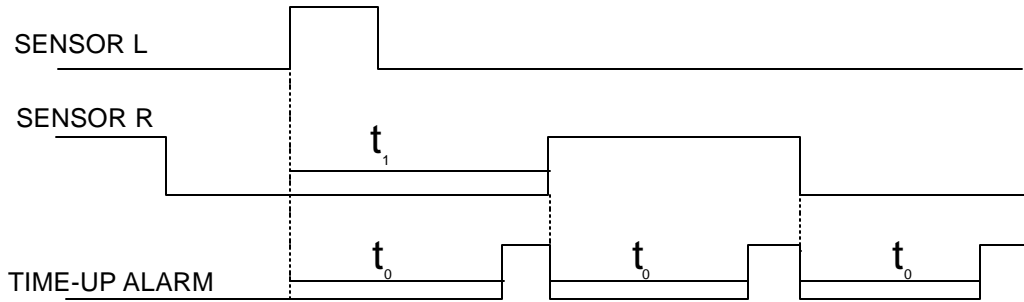

Figure 10

9 Operation

Preparation

1. Check the maximum specified stroke rate of the pump to be used, and set the dip switches on the controller printed board appropriately (see Tables 1 and 2 and Figure 11).

Table 1

SW1	SW2	Equivalent Stroke Rate
OFF	OFF	80 spm
ON	OFF	120 spm
OFF	ON	150 spm
ON	ON	200 spm

2. Double-check the wiring of the pump, solenoid valve and electropneumatic regulator.
3. Inspect the air plumbing layout and all connections. Set the air pressure of the manual regulator to the maximum for the pump series (refer to Section 7 "Air Piping").
4. Set the speed dial and timer dial to the desired values. When setting a pump speed based on a desired flow rate, calculate the pump stroke rate from the desired flow rate and the following formula (refer to Table 3).

Table 2

Pump Model Series	Max. Specified Stroke Rate (spm)
FF-10HT	120
FF-20HT	120
FF-40HT	80
FH-20R	120
FH-40R	80
FF-10B/C	120
FF-20B/C	120
FA-2E	150
FA-40VEW	80
FW-20HT	120
FW-40HT	80
FW-80T	80
FZ-20T	120

$$N=1000 \times Q/q$$

Where:

N= pump stroke rate (spm)

Q= desired flow rate (L/min)

q=approximate 1-shot discharge volume (cc/shot)

Table 3

Pump Model Series	Logical 1-shot Flow Rate (cc/shot)
FF-10HT	93
FF-20HT	185
FF-40HT	500
FH-20R	190
FH-40R	500
FF-10B/C	93
FF-20B/C	204
FA-2E	15
FA-40VEW	500
FW-20HT	200
FW-40HT	515
FW-80T	1030
FZ-20T	204

Note:

The approximate 1-shot discharge volume varies with mechanical differences and pump operating conditions. It should only be considered as a guideline.

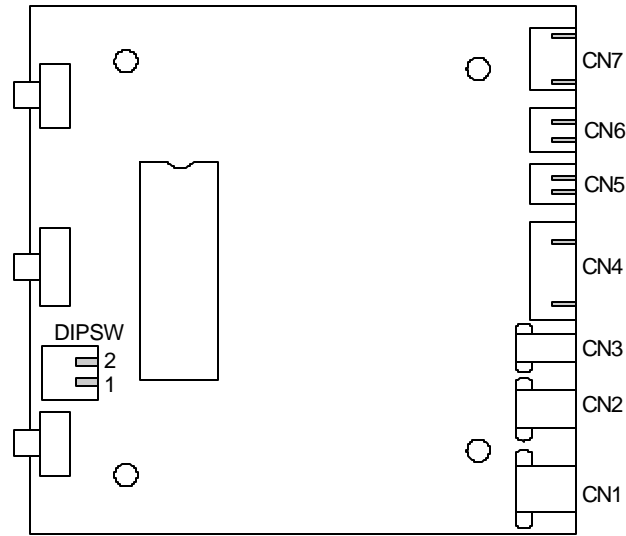

Figure 11

Starting Pump Operation

1. Slide the switch on the front panel to the MANU position. The pump will start operation. To stop the pump, slide the switch to the STOP position and reduce the air pressure of the manual regulator to zero.
2. To start the pump externally, slide the switch on the front panel to the AUTO position. Sending an external start signal from the host controller will start pump operation. Disengaging this signal will stop pump operation.

10 Troubleshooting

Symptom	Causes	Countermeasure
Pump doesn't start.	Power is not supplied.	Check that power switch is ON.
	Faulty wiring.	Refer to Figure 7.
	Sensor L is mistaken for Sensor R.	
	Faulty wiring of 3 leads of sensor.	
	Disconnected sensor lead.	
	Faulty wiring to solenoid valve or electropneumatic regulator	
	Faulty wiring to external start signal.	
	Faulty air piping.	
	Faulty switching of solenoid valve.	Inspect or replace solenoid valve.
	Pump malfunctions.	Inspect or replace pump.
Speed dial is set at 0%.	Reset dial.	
Pump starts but stops.	Speed setting level is too low.	Increase speed setting value.
	Supply air pressure falls below pump's lowest driving air pressure.	Increase air pressure.
	Load on pump discharge side is low.	Decrease speed setting value.
Set stroke rate cannot be maintained.	Load on pump discharge side is too high & supply air pressure has reached upper limit. (Value was set beyond pump's capacity.)	Reduce speed setting. Replace filter which is likely to be clogged.
	FD-2 dip switches do not match maximum stroke rate of pump.	Correct dip switch setting.
	Supply air pressure to electropneumatic regulator is not set correctly.	Adjust air pressure to maximum of pump series (see section 7).
Leak alarm output is activated.	Electrodes inside the pump are conducting.	Replace bellows or pump unit.
	Bellows are damaged.	
	Liquid splashes out of pump unit.	
	Wiring between electrodes is short-circuited.	Wipe off liquid from electrode section outside the pump to prevent splashing. Remove short-circuited section and correct wiring.
Time-up alarm output is activated.	Pump discharge pressure increases.	Inspect discharge conditions.
	Supply air pressure lowers.	Inspect for cause & reset pressure.
	Pump unit malfunctions.	Inspect or replace pump as necessary.

Iwaki Walchem Corporation
5 Boynton Road Hopping Brook Park Holliston, MA 01746 USA
Tel: 508-429-1440 Fax: 508-429-1386 Web: www.iwakiwalchem.com