



***IWAKI WALCHEM
CFD BELLOWS PUMP
INSTRUCTION MANUAL***

Thank you for purchasing a CFD Series Bellows Pump. This pump is designed for use in metering high purity chemicals.

(1) This instruction manual deals with the correct handling, operation, maintenance, inspection, and troubleshooting methods for the pump. To ensure safe and efficient operation, please read this manual carefully before actually handling and operating the pump.

(2) The use of this pump involves the handling of considerably dangerous liquids such as strong acids. Be sure to take adequate safety measures before operating it.

(3) The CFD series pumps can be operated directly by host computers, PLCs or with the use of Iwaki controller models APD-1 or APD-3. Please read the respective instruction manuals carefully to ensure safe and efficient operation.

CONTENTS

1	UNPACKING AND INSPECTION.....	1
2	SPECIFICATIONS	1
3	HANDLING INSTRUCTIONS	5
4	INSTALLATION, PIPING, AND WIRING	5
5	OPERATION, ADJUSTMENT, AND ALARMS (WHEN USED WITH APD CONTROLLERS).....	13
6	MAINTENANCE AND INSPECTION.....	16
7	WEAR PARTS.....	16
8	TROUBLESHOOTING GUIDE	17
9	PARTS DESCRIPTION AND EXPLODED VIEW	18

1 Unpacking and Inspection

Open the package and check that the product conforms to your order. Also, check each of the following points. For any problem or inconsistency, contact your distributor at once.

1. Check that the model number indicated on the nameplate conforms to the specifications of your order.
2. Check that all the accessories you ordered are included. Check that the pump body and parts have not been accidentally damaged or that any bolts or nuts have not been loosened in transit.



2 Specifications

• Pump Specifications

General Specifications		CFD-8T-B-W0X*	CFD-8T
	Max. discharge per shot† oz (ml)		.33 (10)
Max. pressure PSI (kgf/cm ²)		7.11 (0.5)	
Max. stroke spm		30	
Supply air pressure PSI (kgf/cm ²)		21-43 (1.5-3.0)	
Temperature range of liquid handled °F (°C)		68-140 (20-60)	
Air consumption Ft ³ /shot (NI/shot)		.006 (0.18)	
Wet end material		PTFE, PFA	
Pump connection port diameter		1/4" OD tube (Ø6.35 x Ø4.35mm)	
Input voltage, Sensors		5 VDC	
Output voltage, Sensors		0 – 5 VDC	
Supply air connection port diameter		1/4" NPTF	M5
Weight lbs (kg)		3.3 (1.5)	2.5 (1.2)

† All models have max. discharge per shot capability of 0.33 oz (10ml).

- For specific models, please refer to the displacement table provided below. W0X identifies generic model in remainder of manual.

DISPLACEMENT TABLE:

CFD-8T-B-	Nominal discharge per shot oz (ml)
W03	0.26 (8)
W04	0.26 (8)
W05	0.23 (7)
W06	0.33 (10)

- **Sensor Specifications (as given by the manufacturer)**

Input†	Parameter	Symbol	Min	Typ	Max	Unit	Conditions	
	Forward voltage	V_F	--	1.1	1.4	V	$I_F = 5\text{mA}$	
Reverse current	I_R	--	--	10.0	μA	$V_R = 3\text{V}$		
Operating supply voltage range	V_{CC}	4.5	--	17.0	V			
Output	Low level output voltage	V_{OL}	--	0.15	0.4	V	$V_{CC} = 5\text{V}$ $I_F = 0\text{mA}$ $I_{OL} = 16\text{mA}$	
	High level output current	V_{OH}	4.9	--	--	V	$V_{CC} = 5\text{V}$ $I_F = 5\text{mA}$	
	Low level supply current	I_{CCL}	--	1.7	3.8	mA	$V_{CC} = 5\text{V}$ $I_F = 0\text{mA}$	
	High level supply current	I_{CCH}	--	0.7	2.2	mA	$V_{CC} = 5\text{V}$ $I_F = 5\text{mA}$	
Transfer Characteristics	*1	"L-H" threshold input current	I_{FLH}	--	1.0	5.0	mA	$V_{CC} = 5\text{V}$
	*2	Hysteresis	I_{FHL}/I_{FLH}	0.55	0.75	0.95		$V_{CC} = 5\text{V}$
	*3 Response Time	"L-H" propagation time	t_{PLH}	--	3.0	9.0	μs	$V_{CC} = 5\text{V}$ $I_F = 5\text{mA}$ $R_L = 280\Omega$
		"H-L" propagation time	t_{PHL}	--	5.0	15.0		
		Rise Time	t_r	--	0.1	0.5		
Fall Time	t_f	--	0.05	0.5				

† Input voltage is limited to 5VDC due to circuit board components.

*1 I_{FHL} represents forward current when output goes from "H" to "L"

*2 I_{FLH} represents forward current when output goes from "L" to "H"

*3 Test circuit for response time is shown below

Note: In case of interruption of light between emitter and detector, output becomes "Low Level"

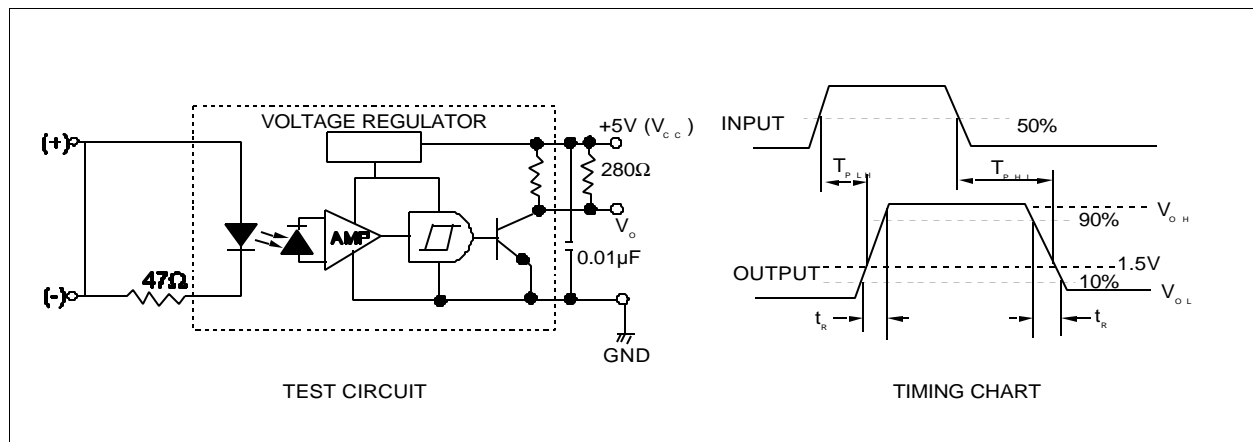

External Dimensions

CFD-8T-B-W0X

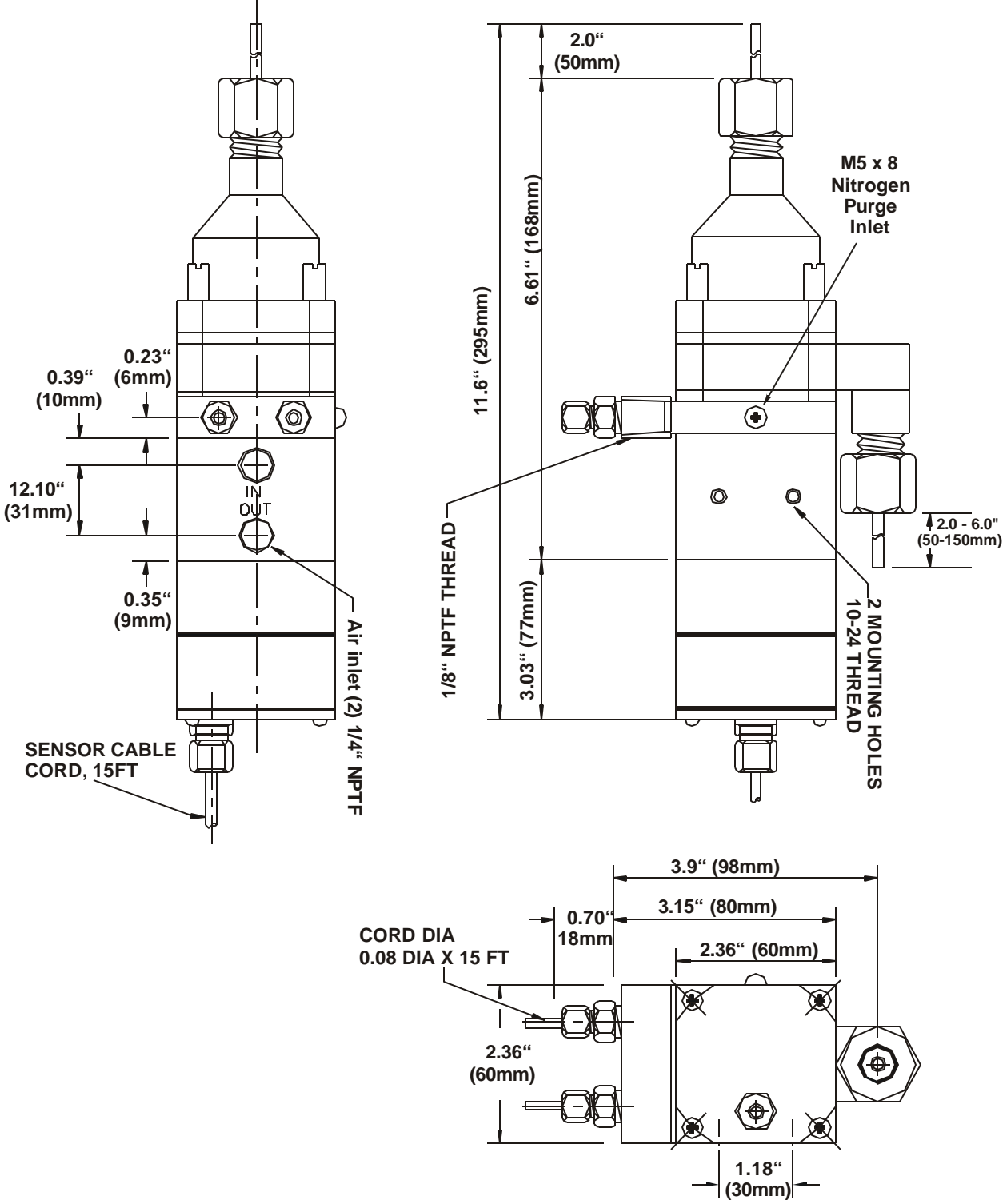

CFD-8T

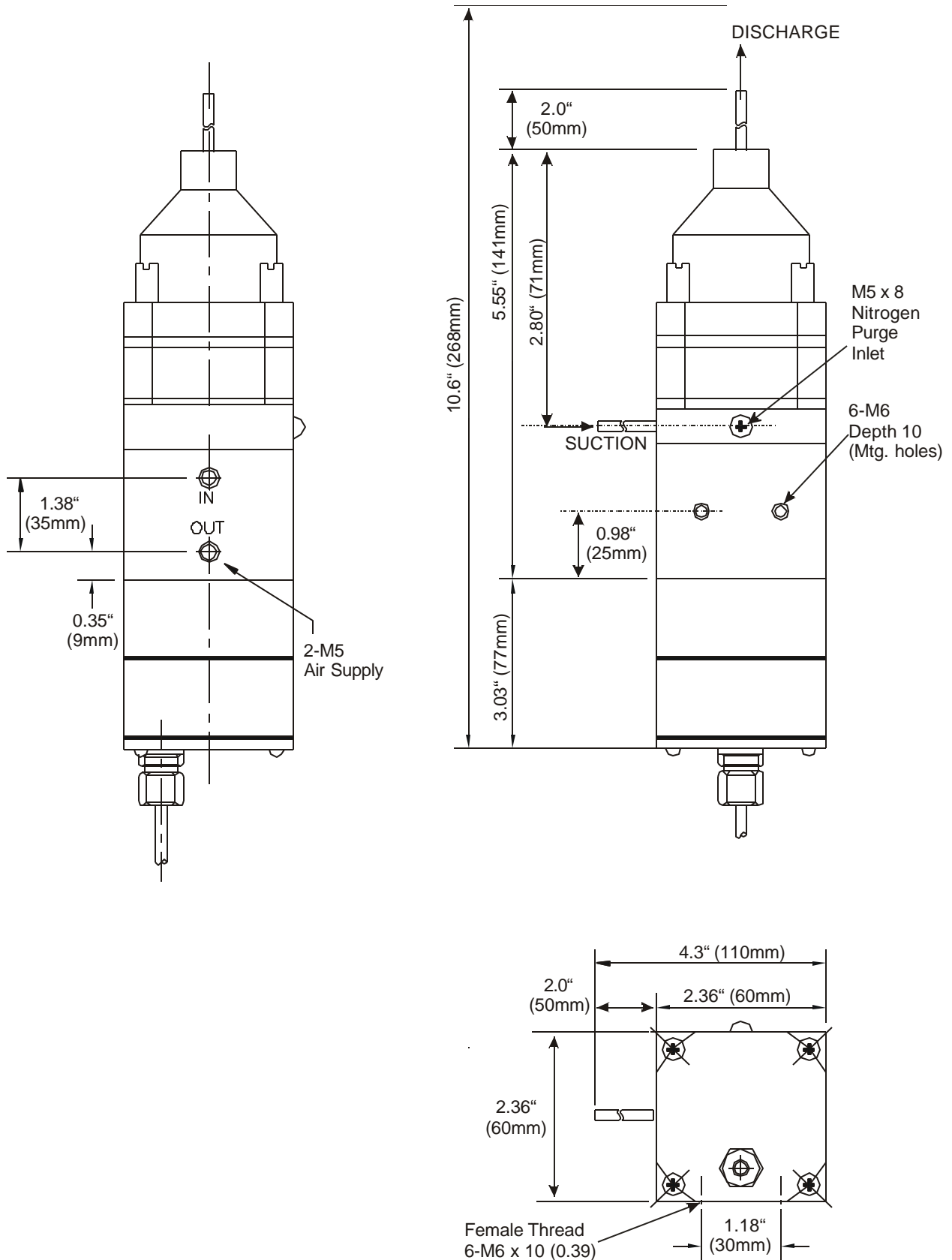

3 Handling Instructions

1. Never operate the pump with the discharge side valve or piping closed. This will raise the pressure in the pump head excessively, resulting in faulty operation.
2. Handle the photo sensor lead wires carefully. Note that forcibly twisting the cord during the wiring process or readjusting on site may result in damage to the inner element or cable leads.



DANGER When handling an aggressive (hazardous) chemical that could injure workers or damage machinery in the vicinity, take appropriate protective measures against possible pump malfunctioning. Never fail to carry out daily and other periodic inspections.



CAUTION To prevent malfunctioning due to a mixture of water, oil, dust, etc., use humidity- and dust free, clean instrumentation air as the supply air.



CAUTION If pump operation is suspended for a long period (more than one week), remove all chemicals from the inside of the pump and fill with pure water. Some chemicals (HCL, etc.) can gaseously permeate the PTFE bellows and metallic shafts can be corroded if chemicals remain inside the pump chamber during suspended operation.

4 Installation, Piping, and Wiring

- **Installation**

1. Install the pump as close to the supply tank as possible.
2. Orient the pump vertically with the discharge port upward and the suction port down, and make sure the bellows in the pump moves up and down. If the pump is not positioned vertically, its performance will be affected due to entrapped air in the pump chamber.
3. Use 10-24 or M5 screws, depending on the model, to mount the pump firmly to an appropriate mounting plate or wall.

- **Connection**

Carry out the connection of the pump, air-operated valves, and the controller in accordance with the following diagrams.

CFD-8T pump and Host controller:

The diagram below details the basic connections for the CFD pump and a host controller system. The following inputs and outputs are required for operating the CFD pump.

CFD pump outputs (inputs to host controller):

- L1, L2 Photosensor - 5 volt DC open collector
- S1, S2 Leak detector - 5 volt DC contact closure

Host controller outputs:

- V(in), V(out) - for CFD-8T models, external suction & discharge valves are required. Standard pneumatic or 24VDC solenoid type Teflon diaphragm valves are recommended for this function.
- SVA - to govern the pneumatic drive piston of the CFD pump, a four way, 5 port 24VDC air control valve is recommended.

- **Operation Overview**

The CFD pump is equipped with two photosensors on the pneumatic drive piston of the pump, which locate the pistons' position during operation. L1 indicates the end of the discharge stroke and full compression of the bellows. L2 indicates the home position for the suction stroke and full extension of the bellows, based on the adjusted stroke length.

Normally, the pump should be at rest with the bellows extended in the suction stroke position, L2 activated, the pump will be ready for discharge.

The host controller outputs a signal to the SVA air control valve, energizing the solenoid when a discharge shot is required. The drive piston of the pump would be pressurized and the discharge stroke would begin. Upon reaching full compression of the bellows and completion of the discharge stroke, L1 is activated and an output signal is sent to the host controller. At this time the host controller should de-energize the SVA air control valve to reverse the direction of air pressure on the pump drive piston to begin the suction stroke. Upon full extension of the bellows and completion of the suction stroke, L2 is activated and an output signal is sent to the host controller. Once L2 is activated again, the pump is ready for another discharge cycle.

In general, the pump is capable of up to 30 shots, or cycles, per minute. Adequate time delays are required between switching valves, etc. to ensure precise metering. Installation of speed control valves on the suction and discharge air supply lines to the pump is also recommended in order to regulate the suction and discharge stroke speed.

In the event of a bellows seal leakage or rupture, the leak detector probes would conduct through the chemistry, and the 5 VDC circuit would close. The host controller should override and cease operation while sending an alarm signal to an operator.



CAUTION Do not use leak detectors with flammable liquid.

For CFD-8T Models Only

External suction and discharge valves V(in) and V(out) are required to isolate the pump chamber. The control signals to the valves should be synchronized with the signal to the main SVA control valve. When signaling a discharge stroke, V(out) should be opened. Upon completion of the discharge stroke and receipt of an output signal from L1, V(out) should be closed and V(in) would be opened for the suction stroke. Upon completion of the suction stroke, V(in) should be closed and the pump would be ready for the next discharge cycle.

L1, L2	Photo sensor
S1, S2	Leak sensor*
SC	Speed controller
V (IN)	External suction valve
V (OUT)	External discharge valve
SVA	Air control valve, 4 way, 5 port

*Leak sensors are optional items on the CFD-8T pump

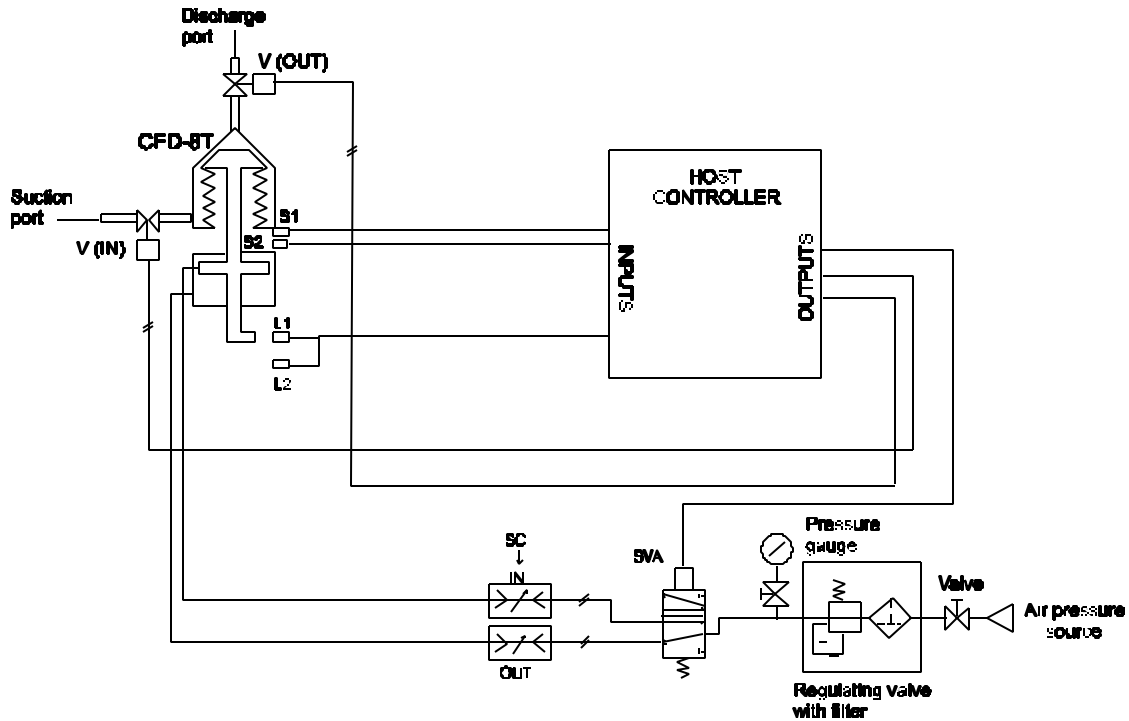

CFD-8T pump and APD-1 Controller:

L1, L2	Photo sensor
S1, S2	Leak sensor ¹
V (IN) V (OUT)	Air operated valve ²

CFD Sensor Cable Lead Color Code	
Red	+5V
Black	Ground
White	L1 signal
Green	L2 signal

- 1 Leak sensors are optional items
- 2 Air operated valves are external to the pump and are required on suction & discharge lines for CFD-8T models

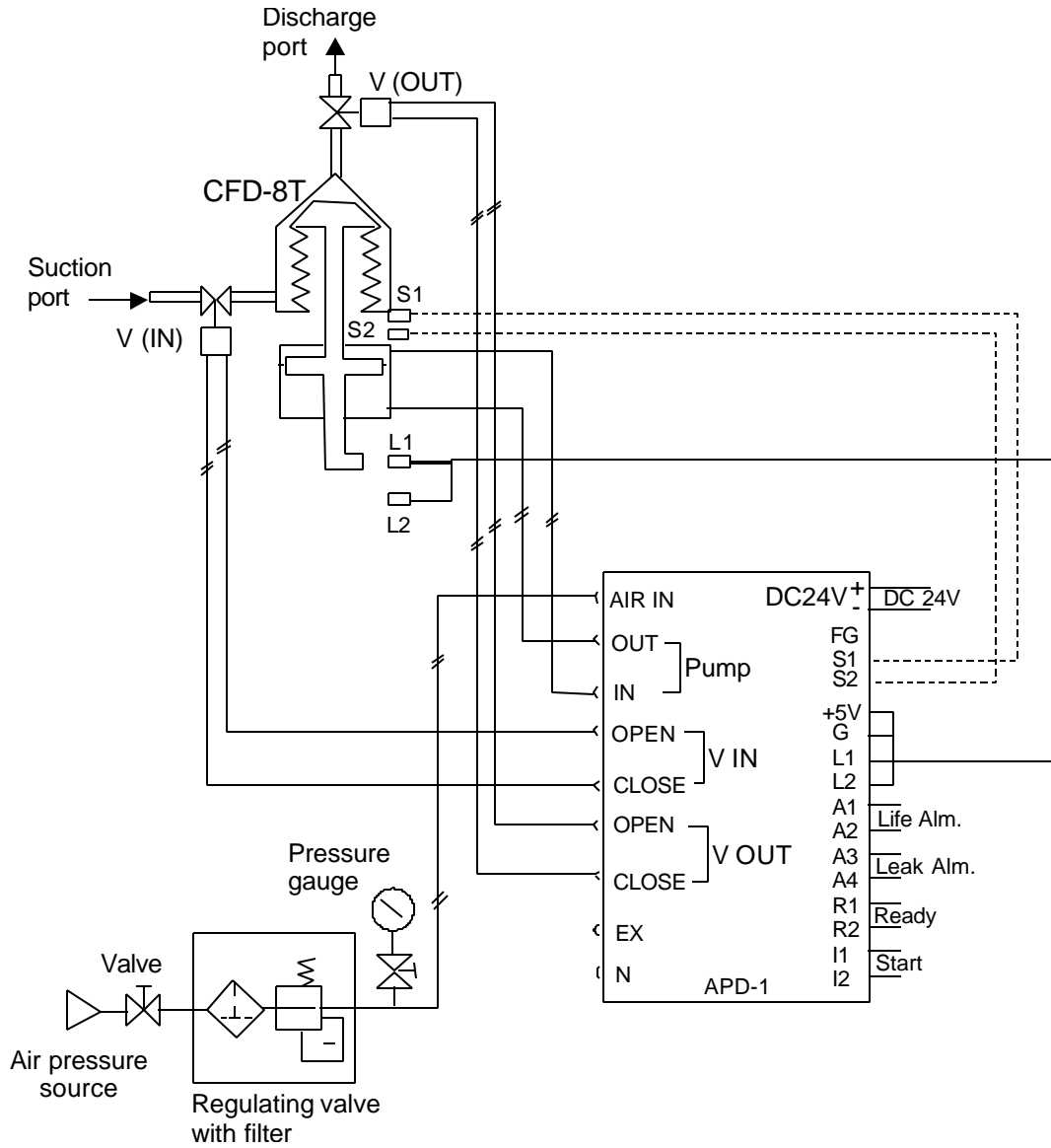

CFD-8T-B-W0X pump and APD-3 controller:

L1, L2	Photo sensor
FR	*Regulator with filter
SVA	*Solenoid valve
SC	* Speed controller

* The user should prepare the regulator with filter, solenoid valve and speed controller.

CFD-8T-B-W03 models incorporate ball check suction and discharge valves, no external line valves are necessary.

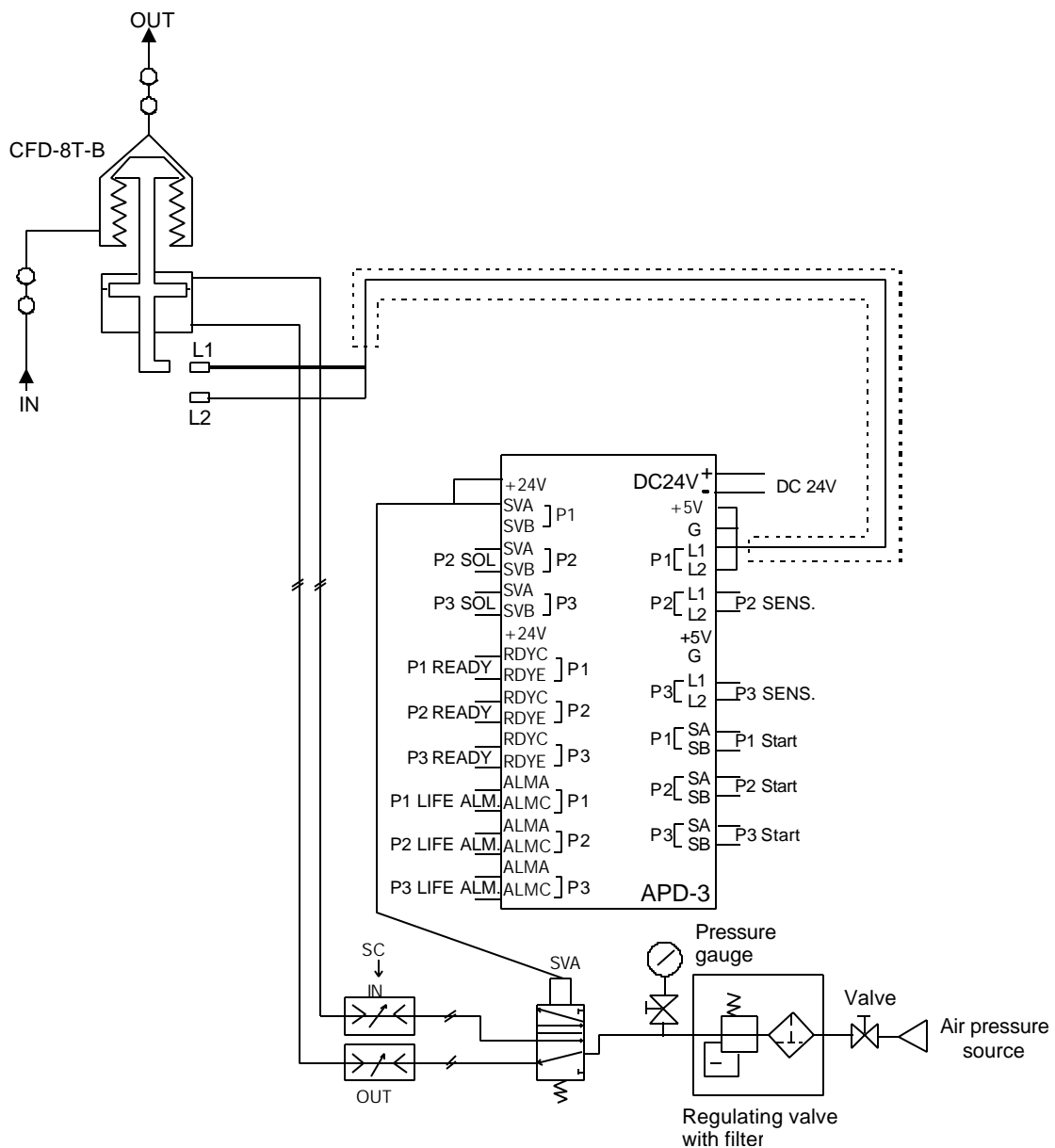

- **Pump Piping**

1/4" O.D. PFA tubes are used for the standard discharge and suction line connections. Observe the following piping procedures.

1. Teflon compression fittings available from many manufacturers may be used. However, select those that assure a leakproof connection, considering the pressure and characteristics of the operating liquid.
2. The connections must be fastened firmly so that no air suction or liquid leakage can occur.
3. The piping should be as short as possible. In addition, the number of bends, joints, cocks, and solenoid valves that increase piping resistance should be kept to a minimum.
4. The diameter of the pipe must be the same or larger than that of the pump discharge and suction ports.
5. In case of self-priming application:
Recommended flow chart

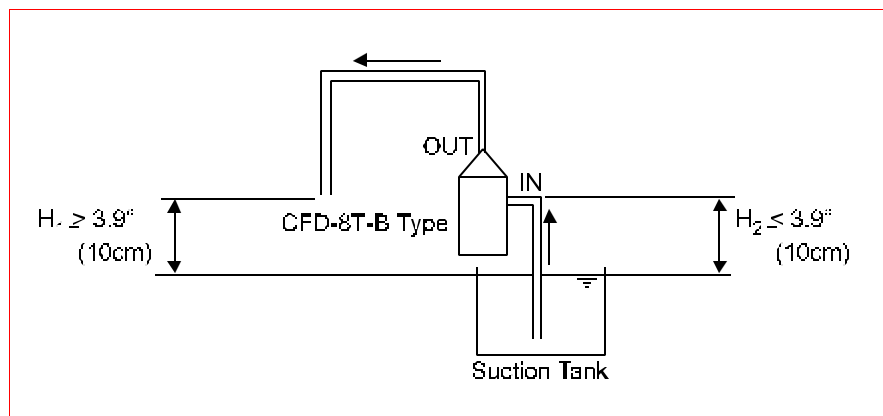

- a) Minimum differential height between the discharge tubing end and the liquid level of the supply tank (H_1) must be 3.9 inches (10cm) or more.
- b) Differential height between the pump and the liquid level of the supply tank (H_2) should be kept within 3.9 inches (10cm). If this distance is exceeded, some chemicals may outgas due to their specific properties and existing temperature condition. This decreases pump performance. Consult Iwaki Walchem for details.

6. In case of flooded suction:
Example of flooded suction

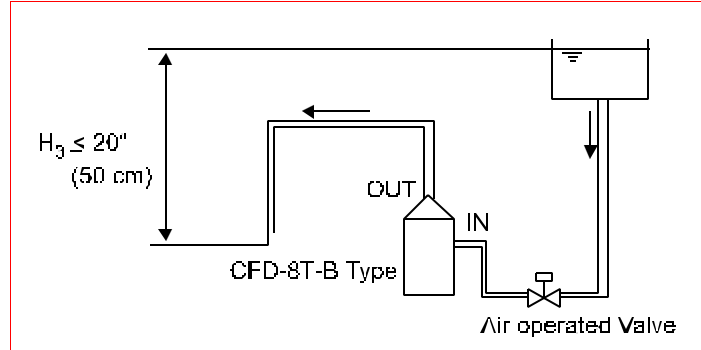

- a) In order to prevent siphoning, install an air-operated valve between the pump and the supply tank.
- b) Differential height between the liquid level of the supply tank and discharge tubing end (H_3) should be 20" (50cm) or less. If this value is more than 20" (50cm), the dispense volume is increased by the effects of gravity at the supply tank and the pump loses accuracy. Note: 20" (50cm) is the value for clear water. When liquids of higher specific gravity are used, use the following formula:

$$\text{Maximum differential height} = 20" (50 \text{ cm}) / \text{specific gravity}$$

- **Air piping**

Use 1/4" NPT male or M5 thread connectors, depending upon pump model, to join the air supply tubing or pipe to the pump air supply port. Observe the following piping procedures.

1. Use a 1/4" O.D. x 3/16" I.D. (or 6mm x 4mm) tube to connect the air supply pipe with the controller and/or control valving.
2. Carry out sufficient flushing inside the air supply tubing or pipe to remove any rust, burrs, and other foreign matter prior to installation.
3. Use humidity and dust-free, clean instrumentation air as the supply air.

For APD-3 or Host controller:

1. Connect air tubing or piping from secondary side of switching valve controlled by a host controller or APD-3 Iwaki controller, to the respective CFD pump air inlet ports.
2. a) CFD-8T models have one M5 threaded port on the suction tubing side of the pump which should be used to exhaust gas from the internal drive section of the pump.
- b) CFD-8T-B models require the use of a Teflon compression fitting and tubing jacket around the leak sensor cables to exhaust gas from the internal drive section of the pump.

Note: Gas permeation through the PTFE liquid end will occur with certain chemicals such as HF or nitric acid, etc. If the internal drive section of the pump is not properly exhausted to remove these vapors, corrosion to the drive shaft and surrounding components may occur. A nitrogen purge is recommended to avoid corrosion damage to the pump drive. Use the M5 x 8 hole for nitrogen. It will be exhausted out the two leak sensor connectors.

For APD-1:

1. Extend the pipe from the secondary side of the regulating valve to the <AIR IN > port of the controller.
2. Connect the pump air supply lines and the controller by connecting OUT with OUT and IN with IN on the controller and the pump.
3. Connect V-IN and V-OUT on the controller with the respective air-operated suction and discharge valves (for CFD-8T models only).

Refer to the APD-1 or APD-3 controller manual for additional installation details.

• **Electrical Wiring**

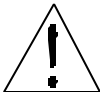

CAUTION Faulty wiring may cause failure or malfunctioning of the photo sensor built into the pump.

For APD-1 or APD-3:

1. *Connection of power source to APD controllers*
Connect a power source of 24V DC $\pm 10\%$ with the 24V DC (+, -) terminals.
2. *Connection of lead wires from the CFD pump*
Connect the pump lead wires (+5V, G, L1, L2) of the pump with the IN (+5, G, L1, L2) terminals respectively. For multiple pump installations using the APD-3 controller, maintain consistent use of P1, P2 and P3 terminals for all input/output connections.
3. *Connection of external control systems to the APD controllers*
Connect each system with each terminal on the controller, such as LIFE ALM (ALMA ALMC), READY (RDYC, RDYE) and START (SA, SB).

Refer to the APD-1 or APD-3 controller manual for additional installation details.

5 Operation, Adjustment, and Alarms (when used with APD controllers)

- **Operation**

1. Supply power (DC 24V \pm 10%) to the APD-1 or APD-3 type controller.
2. Set the air supply pressure at 28 to 43 PSI (2 to 3 kgf/cm²) by adjusting the regulating valve on the air supply line.

(For use with the APD-1 controller, fully rotate the speed controller clockwise on the APD-1 front panel.)
3. Set the ON LINE/OFF LINE selector switch to 'OFF LINE' and press the MANU START button. The pump operates only for the preset shot number and then stops. Adjust the stroke speed of the pump by regulating the air volume supply via the speed controller.
4. Set the ON LINE/OFF LINE selector switch to 'ON LINE' when activating the pump via the external input method. When a start signal is input, the pump begins operation and will automatically execute the preset shot number of strokes and then stop.
5. When the controller has reset, an output signal is sent to the external controller and the system is prepared for the next control input signal.

- **Adjustment of Discharge**

The discharge is controlled by a dual system, i.e.; adjustment of the number of strokes through the APD-1 or APD-3 type controller and adjustment of the length of stroke through a built-in adjusting screw on the pump itself.

1. Method of Control

The number of strokes ranges from 0 to 30 spm and is determined by the speed controller adjustment of the air supply line. As the pump is set at 8 ml/shot by the factory, this means that the discharge can be controlled in a range from 0 to about 240 ml/min (300ml/min maximum setting achievable).

Adjustment of the number of strokes

For adjusting the number of strokes, the APD-1 or APD-3 controller is used. See the appropriate controller manual for the proper procedure.

Adjustment of the length of stroke

This method is used to change the amount of discharge (i.e., to increase or decrease the discharge per shot). The length of stroke is adjusted by means of the adjusting screw provided in the pump. For this adjustment, the pump should not be operating. It must be stopped.

Range of adjustment (guideline): 7~10 ml
(Set according to model# / displacement table by the factory)

Adjusting screw

The adjusting screw is turned by the use of a straight screwdriver. (The length of stroke is changed by 1mm when the screw is rotated a full turn.)

Range of adjustment: 0 to 5 turns (0-5mm in stroke length)

- Turn to the right (clockwise) to decrease the stroke length to decrease the discharge.
- Turn to the left (counter clockwise) to increase the stroke length to increase the discharge.

For the best accuracy, measure the discharge per shot after each turn of the adjustment screw.

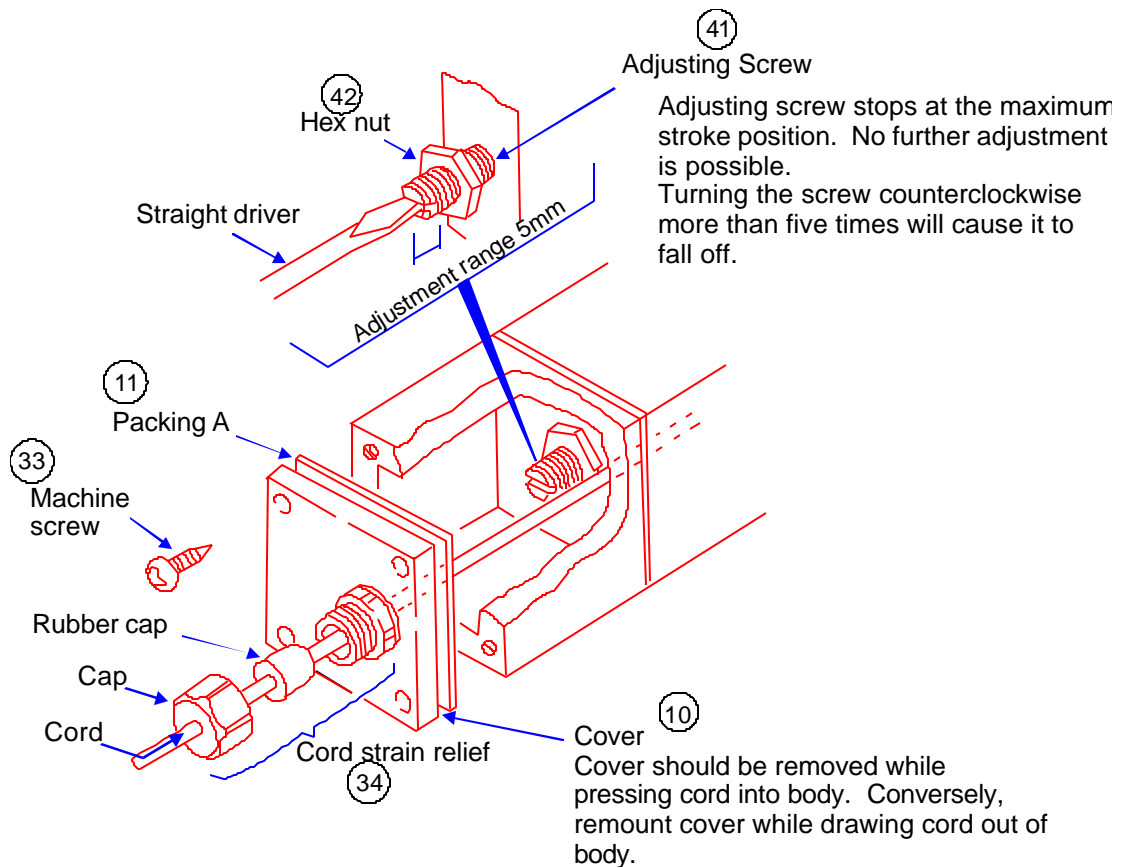

2.

Adjusting Stroke Length

To adjust the length of stroke, stop the pump and follow the steps described below.

- a) Detach the small machine screw (33) from the pump body and remove cover (10).

The cord is fixed to the cord strain relief (34). Undo the cap and pull the rubber sleeve out. Remove the cover while pressing the cord into the body.

- b) Hold a straight screwdriver to the adjusting screw (41) and loosen hex nut (42).

The pump is set according to model# / displacement by the factory. Use this position of the screw as your reference.

- c) Adjust the length of stroke.

If the reference position of the screwdriver is not clear, turn it to the leftmost position first. The stroke length is adjustable up to 5 turns (5mm).

For the most accurate setting, measure the discharge per shot. The pump should be stopped during adjustment and should be activated only when you measure the discharge.

- d) Upon completion of adjustment, fasten the hex nut (42) and attach cover (10).

Tighten the hex nut while holding the adjusting screw lest the latter should rotate out of position.

When you attach the cover, take care not to allow packing A (11) to project or twist.

- **Alarms**

1. *Leak alarm (applicable only if the pump is equipped with a leak sensor)*
If the bellows of the pump is damaged, the leak sensor is activated to turn on the LEAK ALARM LED (orange) on the APD-1 or APD-3 controller. In this case, the pump stops and an alarm is generated.



DANGER Special care should be taken with the liquid when inspecting the pump or piping.

2. *Life Alarm*
If the pump operation reaches the set total count (the number of strokes representing the pump service life) the LIFE ALARM LED (red) on the APD-1 or APD-3 controller turns on and the pump stops. At the same time, an alarm is generated.

Note: After inspecting the pump, air-operated valve, etc., replace worn components and reset the controller.

Refer to the appropriate controller manual for the resetting procedure.

6 Maintenance and Inspection

- **Daily Inspection**

Verify that the pump operates normally and the following points are all satisfied.

1. The sealed sections of the air piping have no leakage.
2. The supply air is clean.
3. The supply air pressure is at a normal level.
4. The supply air volume (cfm) amount is at a normal level.
5. No liquid leakage is detected throughout the piping system.
6. No liquid connections are loose, causing air suction into the pump chamber.
7. The pump actuates smoothly on suction and discharge strokes.

7 Wear Parts

No.	Part Name	Qty	Remarks	Replacement period
2	Bellows	1		1 year
19	O-ring	1	P-8	
20	O-ring	1	P-10	
21	O-ring	1	P-14	
22	O-ring	2	P-26	
52	Valve Gasket	10	CFD-8T-B only	
54	Valve 3/16"	4		
55	Valve Seat	4		

Notes:

1. The quantity of parts indicated is for a single pump.
2. The durability of the expendable parts depends upon the temperature, pressure and characteristics of the applied liquid and duty cycle. The replacement period is a guideline, not a guarantee period.

8 Troubleshooting Guide

Problem	Causes	Countermeasures
Pump does not start	Faulty setting of photo sensor Bellows is damaged (Alarm output) Supply air pressure or amount is lowered: <ul style="list-style-type: none"> • Compressor is out of order • Pressure set for regulating valve is insufficient • Air filter, etc. is clogged • Air leaks from pipe • Speed controller is set to excessively low speed Controller is out of order: <ul style="list-style-type: none"> • Switching action of solenoid valve is affected • Faulty wiring or disconnection • Faulty piping 	Reset or replace photo sensor Replace bellows Inspect and repair compressor Set pressure correctly Clean or replace element Repair pipe Readjust speed controller Inspect, repair or replace valve Inspect and setup normal wiring Inspect and setup normal piping
Pump starts but does not discharge liquid	Air operated valve is affected: <ul style="list-style-type: none"> • Valve is clogged with foreign matter • Diaphragm is damaged • Faulty air piping • Air enters via suction pipe 	Inspect, clean or repair valve Inspect repair or replace diaphragm Inspect and setup normal piping Further tighten pipe connections
Discharge volume is reduced	Supply air pressure or amount is lowered: <ul style="list-style-type: none"> • Sealing performance of air operated valve is lowered • Valve is clogged with foreign matter • NPSHa is insufficient • Discharge pressure is raised • O-ring in drive section is worn out 	See "Pump does not start" column Replace worn element or valve itself Inspect, clean, repair or replace valve Check suction condition & take necessary measures Check discharge condition and take necessary measures Inspect & replace o-ring

9 Parts Description and Exploded View

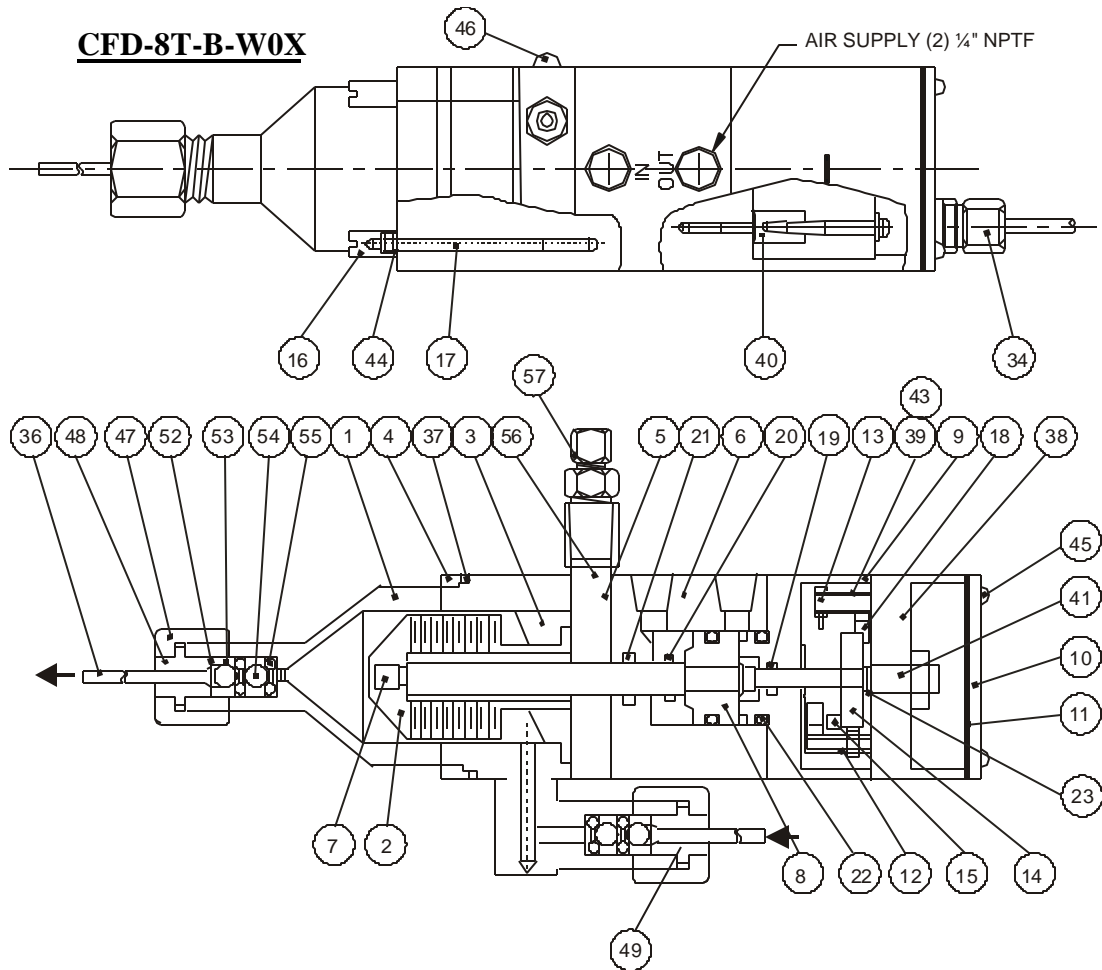

No	Part Name	Qty	Material	No.	Part Name	Qty	Material
1	Pump head	1	PTFE	23	Stop ring	2	SUS304
2	Bellows	1		34	Cord strain relief	1	PP
3	Bellows ring	1		36	Tube	2	PFA
4	Flange A	1	PVC	37	Packing B	2	Silicon Rubber
5	Flange B	1		38	Control case	1	PVC
6	Cylinder	1		39	Installed Base B	1	SUS304
7	Piston rod	1	SUS304	40	Fixed bolt	4	
8	Piston	1	POM	41	Control screw	1	
9	Cylinder cover	1	PVC	43	Spring pin	1	PTFE
10	Cover	1		44	Gasket	4	
11	Packing A	2	Silicon Rubber	45	Screw	4	Polycarb
12	Installed Base A	1	SUS304	46	Screw	1	SS
13	Spacer	3	PVC	47	Valve cap	2	PP
14	Guideplate	1		48	Discharge port	1	PTFE
15	Guide	1	SUS304	49	Suction port	1	
16	Nut A	4	PVC	52	Valve gasket	10	
17	Stud Bolt	4	SUS304	53	Valve guide	4	FKM
18	Sensor	2	---	54	Valve ball	4	
19	O-ring	1	FKM	55	Valve seat	4	
20	O-ring	1		56	Screw	2	SS
21	O-ring	1		57	Male conector	2	PFA
22	O-ring	2					

CFD-8T

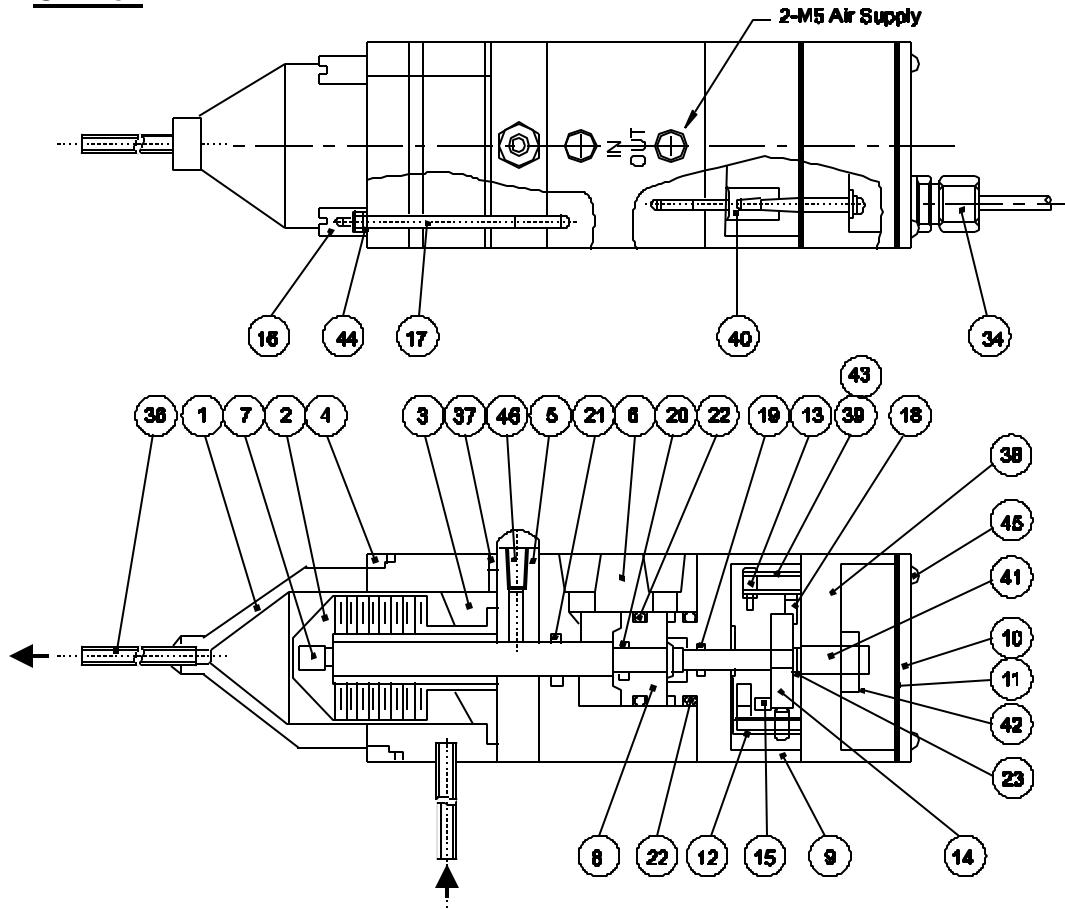

No	Part Name	Qty	Material	No.	Part Name	Qty	Material
1	Pump head	1	PTFE	18	Sensor	2	---
2	Bellows	1		19	O-ring	1	FKM
3	Bellows ring	1		20	O-ring	1	
4	Flange A	1		21	O-ring	1	
5	Flange B	1	PVC	22	O-ring	2	SUS304
6	Cylinder	1	23	Stop ring	2		
7	Piston rod	1	SUS304	34	Cord strain relief	1	PP
8	Piston	1	POM	36	Tube	2	PFA
9	Cylinder cover	1	PVC	37	Packing B	2	Silicon rubber
10	Cover	1		38	Control case	1	PVC
11	Packing A	2	Silicon Rubber	39	Installed Base B	1	SUS304
12	Installed Base A	1	SUS304	40	Fixed bolt	4	
13	Spacer	3	PVC	41	Control screw	1	
14	Guideplate	1		42	Hex nut	1	
15	Guide	1	SUS304	43	Spring pin	1	
16	Nut A	4	PVC	44	Gasket	4	PTFE
17	Stud Bolt	4	SUS304	45	Screw	4	Polycarb
				46	Screw	1	

5 Boynton Road Hopping Brook Park Holliston, MA 01746 USA
TEL: 508-429-1440 FAX: 508-429-1386 On the Internet: www.iwakiwalchem.com