

# Standard Product Capabilities

Pump solutions from a World Leader



## MXM Series

Intelligent balance of durability, safety and performance

### Capable of handling unexpected process upsets

The MXM series design offers the best combination of durability, safety and performance for a wide range of chemical process applications.

With proven dry run capability and our unique self-radiating bearing lubrication circuit (patent pending) the MXM is able to withstand process-upset conditions. Heat dispersion holes located strategically behind the impeller facilitate removal of frictional bearing heat and improve bearing lubrication and cooling circuit flow under dry run or poor suction conditions.

Two piece rear casing design with reinforced rear casing cover offers improved pressure handling capability and a second barrier for improved safety. Front casing features injection molded liner with guaranteed uniform thickness is fully covered by a ductile cast iron cover for combination of chemical resistance and mechanical integrity. All designs have ANSI 150# flanged connections.

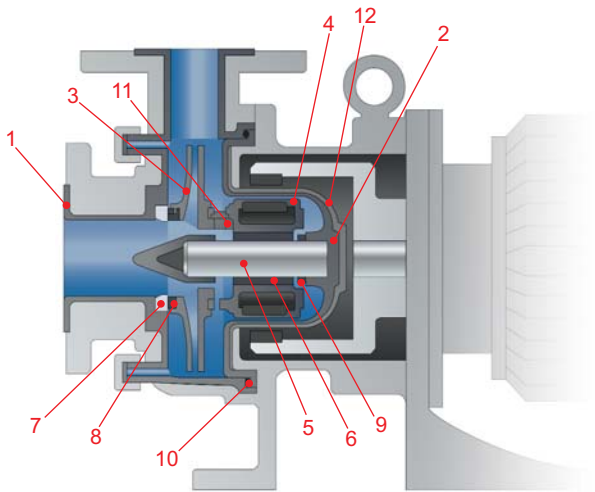

Close-coupled back pull out design with individually replaceable internal parts maximizes ease of maintenance while minimizing operating costs.

Dual end supported precision ground shafts and balanced compact high strength Samarium Cobalt magnet capsules result in balanced lightweight inner magnet capsules optimizing pump efficiency and torque transmission.

### Wet End Materials

	Model	CF	FF	KK
1	Front casing	CFRETFE		
2	Rear casing			
3	Impeller			
4	Magnet capsule			
5	Spindle	High Purity Alumina Ceramic		SiC
6	Bearing	High density carbon	High Purity Alumina Ceramic	SiC
7	Liner ring	High Purity Alumina Ceramic		SiC
8	Mouth ring	PTFE w/filler		SiC
9	Rear thrust	CFRPFA		
10	O-ring	FKM/EPDM/AFLAS®/Da-el perfluoro®		
11	Lock pin	CFRETFE		
12	Rear casing cover	FRP		

*Think twice. Spec Once.*





### Performance Curves

**MXM54-1 Impeller Range 1**

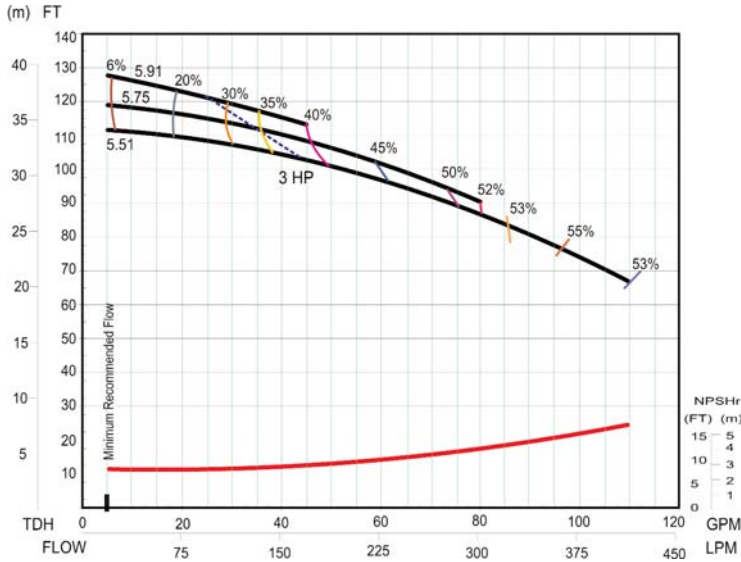

**MXM54-2 Impeller Range 2**

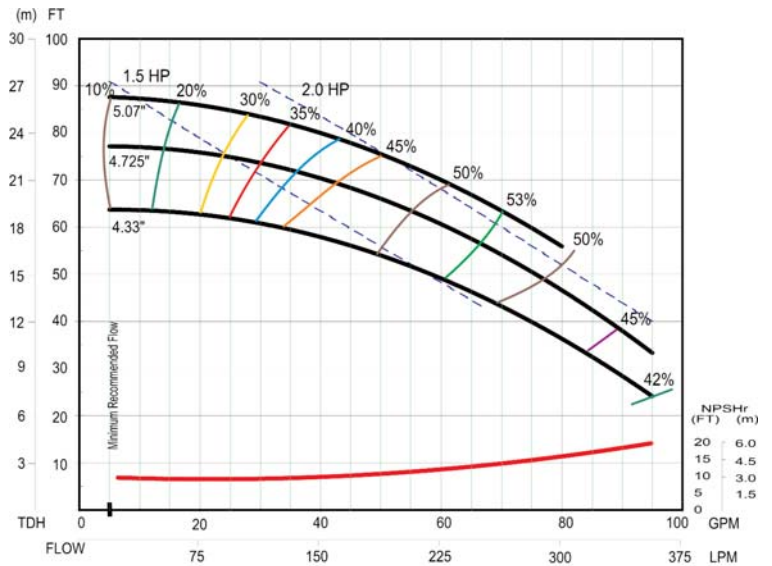

**MXM54-3 Impeller Range 3**

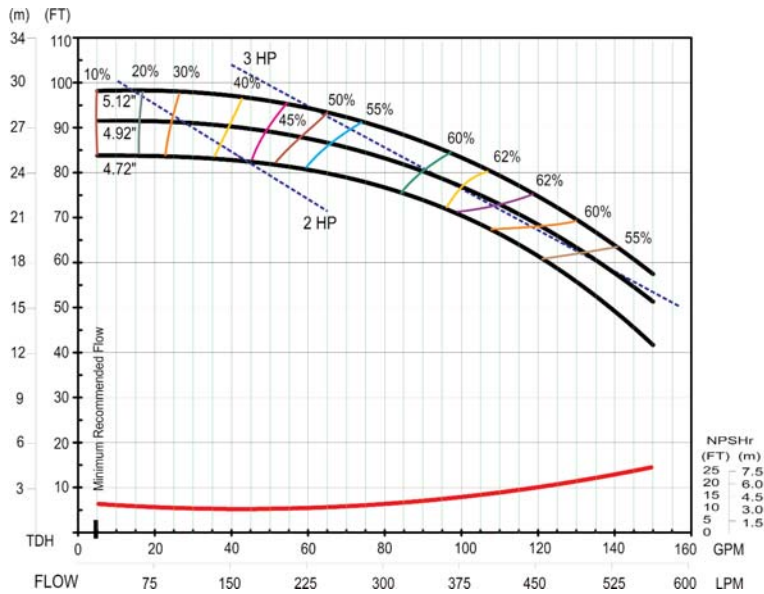

**MXM54-4 Impeller Range 4**

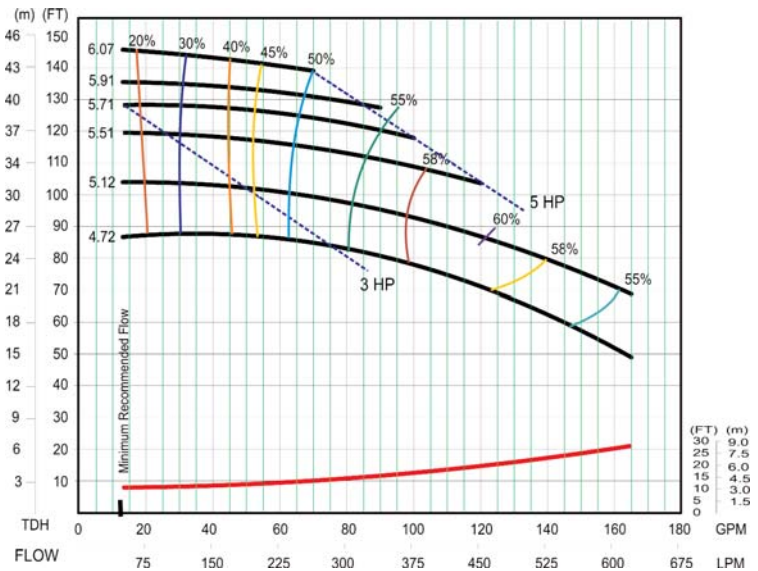

### Specifications

Model	Connection Size Suction x Discharge	Minimum Flow	Maximum Head	Maximum Capacity	Motor /Frame	Pump Weight
MXM54-2	2.0" x 1.5" (50.8 mm x 38.1 mm)	5.5 GPM	98 ft	95 GPM	2 HP / 145 TC	55 lbs
MXM54-3			128 ft	95 GPM	3 HP / 182 TC	55 lbs
MXM54-5		13.2 GPM	146 ft	165 GPM	5 HP / 184 TC	66 lbs



Ductile cast iron casing cover with 150# ANSI flanges with a separate precision injection removable molded casing liner provides the best combination of strength, corrosion resistance and serviceability.



Matched impellers and high strength magnets optimizes performance and efficiency for your application. MXM models feature separate impellers and inner magnets maximizing the flexibility and application of the product.



Our two-piece rear casing design offers increased pressure resistance and inherent secondary containment in the event of damage to the primary internal rear casing. The unique shape of the rear casing also prevents stress concentration and improves the mechanical strength of the rear shaft support.



Utilizing the best materials for corrosion resistance and product integrity the MXM features carbon fiber reinforced precision injection molded liquid contact parts with options of alumina ceramic, carbon or silicon carbide for bearings, shafts and thrust surfaces.

**Dimensions in inches (mm)**

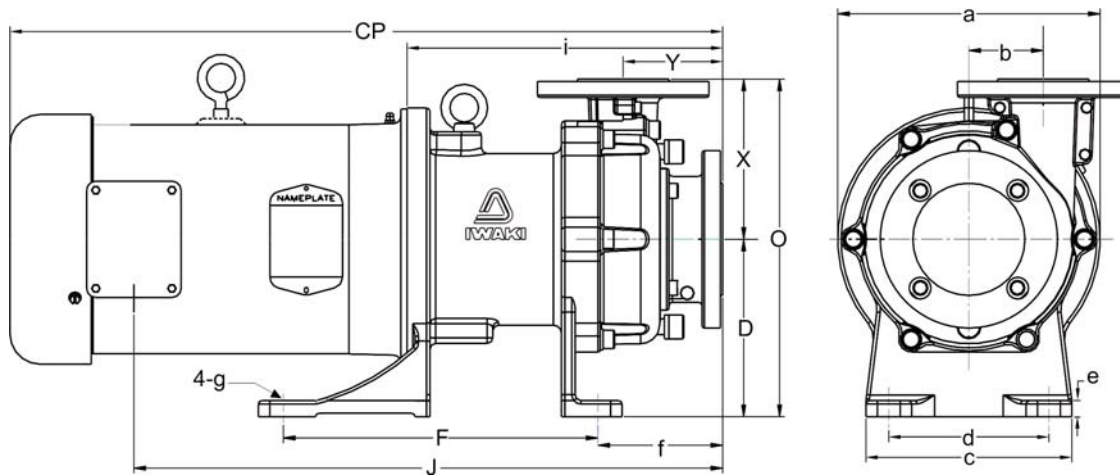

Model	a	b	c	d	D	e	f	F	g	i	J	O	X	Y	CP*
MXM542										11.5 (292.1)					21.90 (556.2)
MXM543	9.9 (251.4)	2.6 (66.0)	7.1 (180.3)	5.5 (139.7)	6.1 (154.9)	0.55 (14.0)	4.2 (106.6)	10.8 (274.3)	0.55 (14.0)	10.9 (276.9)	18.5 (469.9)	11.6 (294.6)	5.5 (139.7)	3.4 (86.4)	24.70 (627.3)
MXM545										10.9 (276.9)					24.70 (627.3)

\* Varies according to motor manufacturer



## Our Company



Iwaki America Inc. is one of over 20 global centers for the manufacturing and support of Iwaki pumps. Our 50 plus years of pump design engineering has made us a worldwide leader of the best chemical handling equipment used in OEM, Industrial, Chemical Process and Semiconductor applications. Iwaki America, along with Walchem Corporation share a state-of-the-art manufacturing facility in Holliston, Massachusetts.



**WALCHEM**

Located 30 miles southwest of Boston, Iwaki America Inc. and Walchem Corporation are strengthened by sharing combined administration and corporate management resources, yet each company maintains and focuses on its own research and development, sales, customer service and manufacturing. Our modern facilities provide enhanced communications between all departments and allows for enthusiastic and productive employees, many of whom have been with the company for decades. We utilize the best data management techniques to serve our customers in the excellent manner they have come to expect from us.

## Quality Statement

Iwaki America recognizes the importance of providing true value to its customers from the initial stages of design specification review to the manufacturing and support of the final product. It is our goal to provide the best technical solution possible and the highest quality product in every pump design we produce. With over 900,000 pumps manufactured annually, our quality has been proven by our customers' satisfaction and documented defect rate of less than 0.01 %.

All products are manufactured under an ISO9001:2000 quality system with the required design process, materials control and manufacturing documentation in place to certify our products will meet the performance and quality specifications required by our users.

Our organization's commitment to quality is integral with our mission statement reinforcing the importance of providing superior products and just as important, superior customer service. Iwaki quality is not just in the physical product, but in every aspect of our business.



### Iwaki Japan Saitama Plant

The Saitama plant commenced operations in 1974 and has implemented modern manufacturing technologies to increase production efficiencies in the manufacture of a wide variety of products in small lots. The Saitama plant primarily produces large pumps.

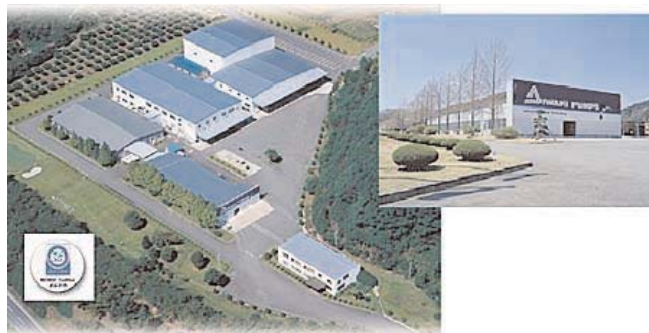

### Iwaki Japan Miharu Plant

The Miharu plant was established in 1977 in Miharu as a mass-production small pump facility. In 1992, this plant introduced a CIM (computer integrated manufacturing) system to become a dedicated factory for small pumps for OEM use, primarily producing the MD series of magnetic-drive pumps, Iwaki's best-selling product.

IALT-00033.C JUL 2008

