

Model	MX-F402		
Mark	CFV	RFV	KKV
1 Front casing	CFRETFE		
2 Impeller	CFRETFE		
3 Rear casing	CFRETFE		
4 Magnet capsule	CFRETFE		
5 O-ring	FKM*		
6 Spindle	High Purity Alumina Ceramic		SIC
7 Bearing	Carbon	PTFE	SIC
8 Rear thrust	CTRETFE		CFRPFA
9 Mouth ring	PTFE		SIC
10 Thrust/Liner ring	High Purity Alumina Ceramic		SIC
11 Lock pin	CFRETFE		

* EPDM and AFLAS® O-ring also available.

MX-F402 2 HP

- Engineered to meet the most severe operating conditions.
- When fitted with a carbon bearing, the MX will allow for brief periods of dry running.
- The MX Series is the first resin magnet pump that uses a *Split Volute Pump Casing* that forms a vortex chamber.
- Self-radiating structure (patent pending) – Heat dispersion holes force the liquid to circulate around the spindle and bearing .

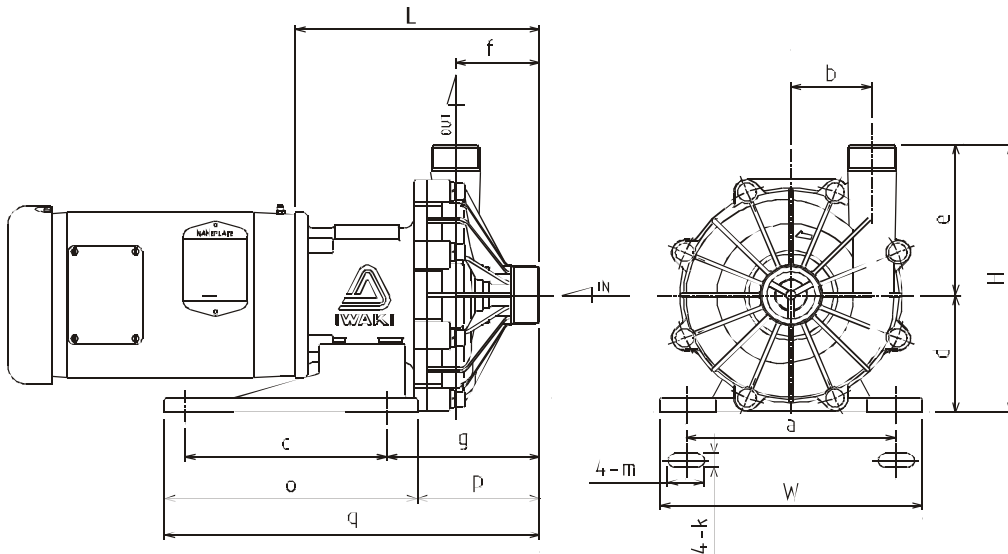

Dimensions (in inches)

a	b	c	d	e	f	g	k	n	o	p	q	W	H	L
8.19	3.15	7.87	4.72	6.06	3.27	5.94	.47	1.42	9.84	4.76	14.61	10.24	10.78	9.53

Specifications

Suction x Discharge	Maximum Discharge Pressure	Maximum Flow	Specific Gravity	Weight (less motor)
2" x 1.5"	70 ft.	120 gpm	1.2	29.8 lbs

