

MX-F100 .35 HP

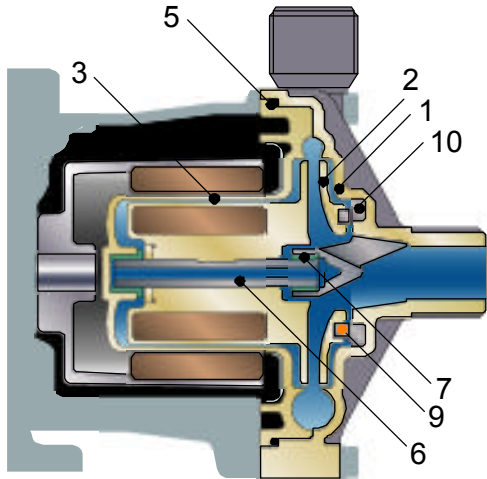

Model	MX-F100	
Mark	RV	KV
1 Front casing	CFRETFE	
2 Impeller	CFRETFE	
3 Rear casing	CFRETFE	
4 Magnet capsule	CFRETFE	
5 O-ring	FKM*	
6 Spindle	High Purity Alumina Ceramic	SiC
7 Bearing	PTFE	SiC
8 Rear thrust	High Purity Alumina Ceramic	SiC
9 Mouth ring	PTFE	---
10 Thrust/Liner ring	High Purity Alumina Ceramic	---

* EPDM and AFLAS® O-ring also available.

Dimensions in inches (mm)

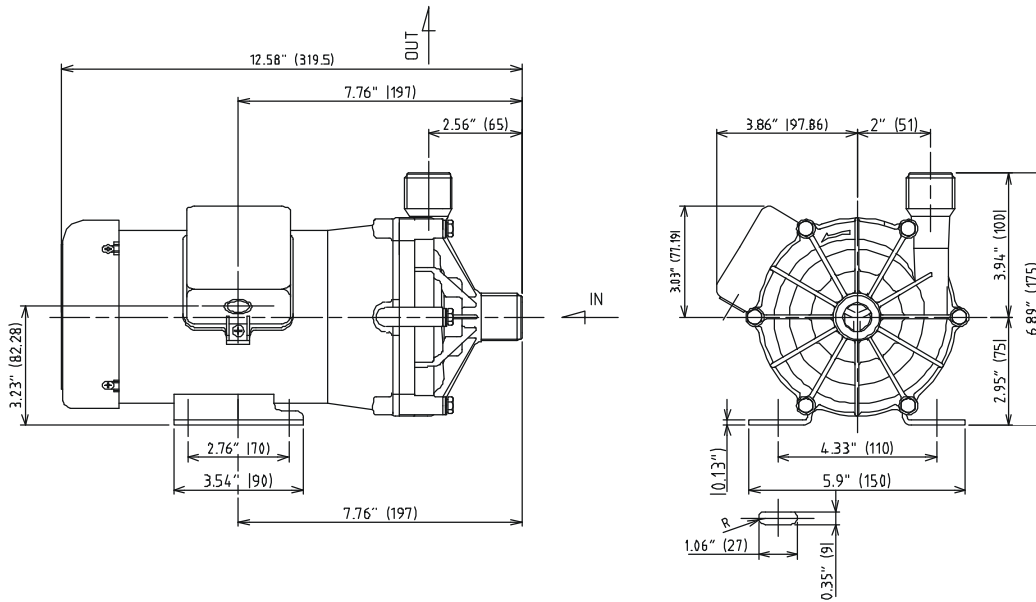

Specifications

50/60 Hz

Suction x Discharge	Maximum Discharge Pressure	Maximum Flow	Specific Gravity	Weight
1" x 1"	Y = 26.9/37.7 ft. Z = ---/ 26.9 ft.	29/33 gpm ---/29 gpm	1.9/1.6 ---/2.3	18.1 lbs

- Engineered to meet the most severe operating conditions.
- The MX Series is the first resin magnet pump that uses a *Split Volute Pump Casing* that forms a vortex chamber.
- Robust construction with strengthening ribs on front and rear casing improve pressure resistance and mechanical strength.

MX-F100

