

# MX-70 .24 HP

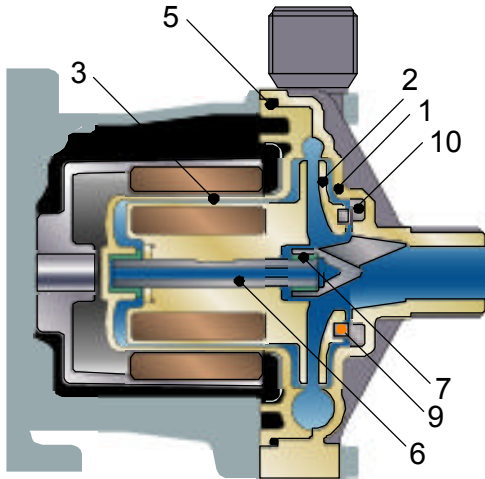

Model	MX-70
Mark	V (E)
1 Front casing	GFRPP
2 Impeller	CFRPP
3 Rear casing	GFRPP
5 O-ring	FKM*
6 Spindle	Alumina Ceramic
7 Bearing	CFRPPS
9 Mouth ring	---
10 Thrust/Liner ring	Alumina Ceramic

\* EPDM and AFLAS® O-ring also available.

- Engineered to meet the most severe operating conditions.
- The MX Series is the first resin magnet pump that uses a *Split Volute Pump Casing* that forms a vortex chamber.
- Robust construction with strengthening ribs on front and rear casing improve pressure resistance and mechanical strength.

## Dimensions in inches (mm)

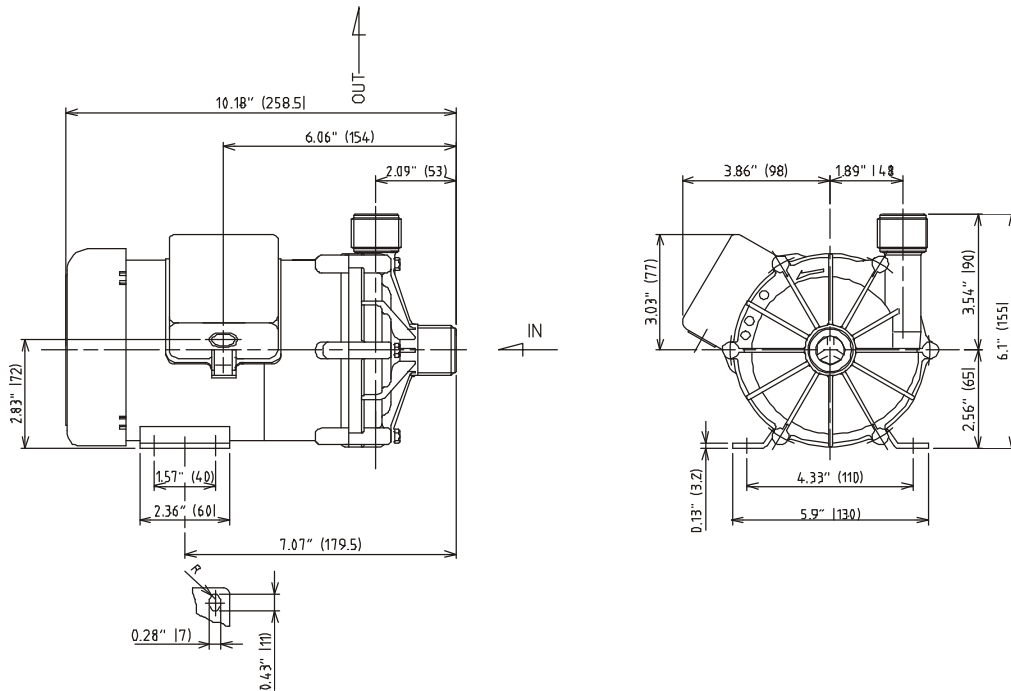

## Specifications

50/60 Hz

Suction x Discharge	Maximum Discharge Pressure	Maximum Flow	Specific Gravity	Weight
1" x 1"	26.2/36.1 ft.	23.8/26.4 gpm	1.0	14.3 lbs

