

Model	MX-250		
Mark	AV (AE)	CV (CE)	RV (RE)
1 Front casing	GFRPP		
2 Impeller	GFRPP		
3 Rear casing	GFRPP		
4 Magnet capsule	PP		
5 O-ring	FKM ¹		
6 Spindle	Alumina Ceramic		
7 Bearing	Alumina Ceramic	Carbon	PTFE
8 Rear thrust	CFRPPS		
9 Mouth ring	PTFE		
10 Thrust/Liner ring	Alumina Ceramic		

1 EPDM and AFLAS® O-ring also available.

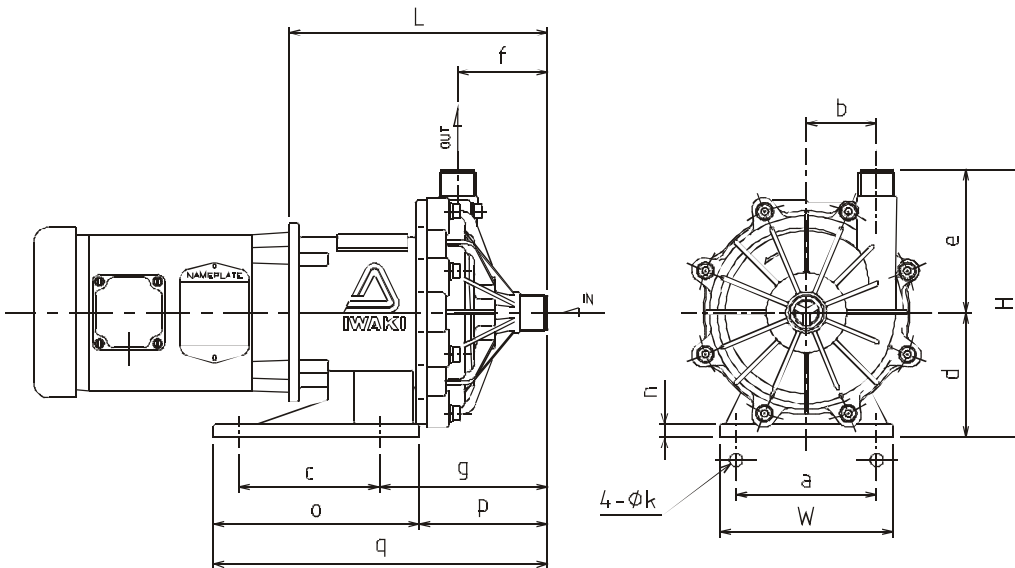

Dimensions (in inches)

a	b	c	d	e	f	g	k	n	o	p	q	W	H	L
5.12	2.56	5.12	4.53	5.22	3.25	6.12	.47	.47	7.48	4.67	12.15	6.30	9.75	9.39

Specifications

Suction x Discharge	Maximum Discharge Pressure	Maximum Flow	Specific Gravity	Weight (less motor)
1" x 1"	53 ft.	40 gpm	1.0	17 lbs

MX-250 .5 HP

- Engineered to meet the most severe operating conditions.
- When fitted with a carbon bearing, the MX will allow for brief periods of dry running.
- The MX Series is the first resin magnet pump that uses a *Split Volute Pump Casing* that forms a vortex chamber.
- Self-radiating structure (patent pending) – Heat dispersion holes force the liquid to circulate around the spindle and bearing .

